

# **An Effective Color Interpolation in CFA Images Using Adaptive Enhancement Technique**

P.Sivasankar <sup>1</sup>, S.Ayyappan <sup>2</sup>

PG scholar, Department of ECE, Sri Subramanya College of Engineering and Technology, Palani, India <sup>1,2</sup>.

**ABSTRACT:** Low cost color interpolation technique proposed for the VLSI implementation for real time applications. Image interpolation is method of forcing new pixel within the range of discrete data points. This is applied diverse areas ranging from computer graphics, editing, and image reconstruction to online image viewing. High performance systems along with low power consumption are mandatory in any systems to be efficient. This technique is less complex and requires reduced memory. The aliasing artifacts resulted by the interpolation is reduced by sharpening filter and clamp filters. This architecture is designed with a SPST (Spurious Power Suppression Technique) adder or unsigned adder which reduces the power consumption and increases speed by considerable amount.

**KEYWORDS:** interpolation, enhancement, SPST(spurious power suppression technique)

## **I. INTRODUCTION**

Digital cameras are integrated into many consumer electronic products, such as digital camera, digital video, smart TV, smart phone, tablet PC, etc. The digital cameras are manufactured by a CCD or a CMOS image sensor that can capture images by color filter array (CFA) technique. The red (R), green (G), and blue (B) colors are sampled as one color in each pixel [1]. Fig. 1 shows a color filter arrays called Bayer CFA, in which two colors have disappeared in each pixel. Thus, it is important to reconstruct the images from CFA to full RGB formats.

B <sub>0,0</sub>	G <sub>0,1</sub>	B <sub>0,2</sub>	G <sub>0,3</sub>	B <sub>0,4</sub>	G <sub>0,5</sub>
G <sub>1,0</sub>	R <sub>1,1</sub>	G <sub>1,2</sub>	R <sub>1,3</sub>	G <sub>1,4</sub>	R <sub>1,5</sub>
B <sub>2,0</sub>	G <sub>2,1</sub>	B <sub>2,2</sub>	G <sub>2,3</sub>	B <sub>2,4</sub>	G <sub>2,5</sub>
G <sub>3,0</sub>	R <sub>3,1</sub>	G <sub>3,2</sub>	R <sub>3,3</sub>	G <sub>3,4</sub>	R <sub>3,5</sub>
B <sub>4,0</sub>	G <sub>4,1</sub>	B <sub>4,2</sub>	G <sub>4,3</sub>	B <sub>4,4</sub>	G <sub>4,5</sub>
G <sub>5,0</sub>	R <sub>5,1</sub>	G <sub>5,2</sub>	R <sub>5,3</sub>	G <sub>5,4</sub>	R <sub>5,5</sub>

Fig.1 Bayer Color Filter Array

## **II. THE PROPOSED ALGORITHM**

The proposed novel color interpolation algorithm is composed of low-complexity edge detection, a green color interpolation, and red-blue color interpolation techniques. Each color is interpolated by different methodologies according to the relative locations and reference neighboring samples. In which the BRg(i, j) and RBg(i, j) represent that the green color pixel g(i, j) was interpolated and prepared when it interpolates R(i, j) and B(i, j). The details of each technique will be described in the following subsections.

# International Journal of Innovative Research in Science, Engineering and Technology

(An ISO 3297: 2007 Certified Organization)

Vol. 4, Special Issue 6, May 2015

SPST :The SPST is a Single Pole Single Throw switch. It is used in electronic as well as electrical circuits.

### A. Low-Complexity Edge Detection

In order to discover the edge information by low-complexity methodology, the difference in the vertical (DV) and horizontal (DH) directions were used. The DV neighboring around the pixel  $G(i, j)$  or  $RB(i, j)$  can be evaluated by

$$DV_i = |RB_{i-1,j-1} - RB_{i+1,j-1}| + |G_{i-1,j} - G_{i+1,j}| + |RB_{i-1,j+1} - RB_{i+1,j+1}| \quad (1)$$

where  $G$  is the pixel in green color and  $RB$  is the pixel in red or blue color in the CFA images. The relative locations and reference neighboring RGB pixels .On the other hand, the difference in the horizontal direction (DH) neighboring around the pixel  $G(i, j)$  or  $RB(i, j)$  can be evaluated by

$$DH_i = |RB_{i+1,j+1} - RB_{i+1,j-1}| + |G_{i,j+1} - G_{i,j-1}| + |RB_{i-1,j+1} - RB_{i-1,j-1}| \quad (2)$$

After obtaining the difference in the horizontal (DH) and vertical (DV) directions, the total difference (TD) neighboring around the pixel  $G(i, j)$  or  $RB(i, j)$  can be calculated by

$$TD_i = DH_{i,j} + DV_{i,j} \quad (3)$$

where DH and DV are all positive value.

### B. Green Color Interpolation

In order to improve the quality of interpolated images, an anisotropic weighting model was created for this design the reference neighboring pixels in horizontal direction are much more than those in vertical direction. The green color pixels can be interpolated by referring to 75 % weighting of pixels in the horizontal direction and 25 % weighting of pixels in the vertical direction. In order to reduce the computing resource of the proposed color interpolation algorithm, all division operations were replaced by shift operations.

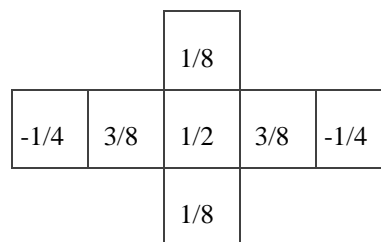
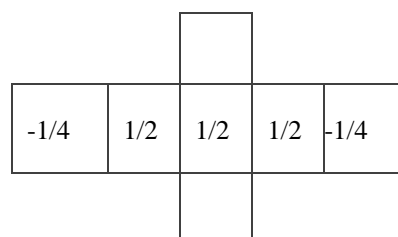

Fig. 2. The parameters of green color interpolation (a) without edge enhancement model



(b) with edge enhancement in horizontal direction model

## International Journal of Innovative Research in Science, Engineering and Technology

(An ISO 3297: 2007 Certified Organization)

Vol. 4, Special Issue 6, May 2015

		3/8		
-1/4	1/8	1/4	1/8	-1/4
		3/8		

(c) with edge enhancement in vertical direction model.

To reconstruct the green color in CFA format image, there are two different causes for interpolating  $G(i, j)$ . the values of TD, DH, and DV can be used to adaptively select one of the three green color interpolation models, without edge enhancement, edge enhancement in horizontal direction, and edge enhancement in vertical direction, as the interpolation model according to the edge information neighboring around the pixel  $G(i, j)$ . If the value of the total difference (TD) is less than the threshold value, the value of  $G(RB)(i, j)$  can be calculated by the without edge enhancement model as

$$G_i, (RB) = 38 (G_{i,-1} + G_{i,j+1}) + 18 (G_{i-1,j} + G_{i+1,j}) + RB_{i,j} - 12 (12 (RB_{i,} + RB_{i,-2}) + 12 (RB_{i,j} + RB_{i,j+2})) \quad (4)$$

Otherwise, if the value of the total difference (TD) is larger than the threshold value and DH is less than DV, the value of  $G(RB)(i, j)$  can be obtained by the edge enhancement in horizontal direction model as

$$G_i, (RB) = 12 (G_{i,-1} + G_{i,j+1}) + RB_{i,j} - 12 (12 (RB_{i,j} + RB_{i,j-2}) + 12 (RB_{i,} + RB_{i,+2})) \quad (5)$$

Also, if the value of total difference (TD) is larger than the threshold value and the value of DH is larger than DV, the value of  $G(RB)(i, j)$  can be computed by the edge enhancement in vertical direction model as

$$G_i, (RB) = 18 (G_{i,-1} + G_{i,j+1}) + 38 (G_{i-1,j} + G_{i+1,j}) + 12 \{RB_{i,} - 12 (12 (RB_{i,} + RB_{i,-2}) + 12 (RB_{i,j} + RB_{i,j+2}))\} \quad (6)$$

By analyzing the parameters of these three green color interpolation models, it is obviously that the characteristic of the compensation for green color is a spatial sharpening filter. This spatial sharpening filter can efficiently reduce the blurring effect. Moreover, the edge information can be enhanced efficiently by the proposed adaptive edge enhancement technique

### C.Red and Blue Colors Interpolation

To reconstruct the red and blue colors in CFA format image, it is important to use the information of the four neighboring green colors. The relative locations and reference neighboring samples of  $G(i, j+1)$ ,  $G(i-1, j)$ ,  $G(i, j-1)$ , and  $G(i+1, j)$  where the pixel in CFA format is  $R(i, j)$  or  $B(i, j)$ . To be able to enhance the edge information, the values of TD, DH, and DV can be used to adaptively select one of the three red and blue interpolation models, without edge enhancement, edge enhancement in horizontal direction, and edge enhancement in vertical direction, as the interpolation model according to the edge information neighboring around the pixel  $R(B) (i, j)$  or  $B(R) (i, j)$ .

1/4	-1/4	1/4
-1/4	1	-1/4
1/4	-1/4	1/4

Fig. 3. The parameters of red and blue colors interpolation at  $G(i,j)$  (a) without edge enhancement model

## International Journal of Innovative Research in Science, Engineering and Technology

(An ISO 3297: 2007 Certified Organization)

Vol. 4, Special Issue 6, May 2015

1/4	-3/8	1/4
-1/8	1	-1/8
1/4	-3/8	1/4

(b) with edge enhancement in horizontal direction model

1/4	-1/8	1/4
-3/8	1	-3/8
1/4	-1/8	1/4

(c) with edge enhancement in vertical direction model

If the value of total difference (TD) is less than a threshold value, then the value of  $R(B)(i, j)$  or  $B(R)(i, j)$  can be calculated by the without edge enhancement model as shown below

$$RB_i, (BR) = 14 (RB_{i-1,-1} + RB_{i-1,j+1} + RB_{i+1,j-1} + RB_{i+1,j+1}) + g_i, - 14 (G_{i-1,} + G_{i+1,} + G_{i,-1} + G_{i,j+1}) \quad (7)$$

where  $g(i, j)$  is created by green color interpolation which is mentioned above. Fig. 3 (a) shows the parameters of red and blue color interpolation without edge enhancement model. Otherwise, if the value of TD is larger than the threshold value and DH is less than DV, then the value of  $R(B)(i, j)$  or  $B(R)(i, j)$  can be obtained by the edge enhancement in horizontal direction model as

$$RB_i, (BR)G = 14(RB_{i-1,j-1} + RB_{i-1,j+1} + RB_{i+1,j-1} + RB_{i+1,j+1}) + g_i, - 18 (3 * (G_{i-1,} + G_{i+1,}) + G_{i,j-1} + G_{i,j+1}) \quad (8)$$

Also, if the value of TD is larger than the threshold value and DH is larger than DV, the value of  $R(B)(i, j)$  or  $B(R)(i, j)$  can be computed by the edge enhancement in vertical direction model as

$$RB_i, (BR) = 14 (RB_{i-1,-1} + RB_{i-1,j+1} + RB_{i+1,j-1} + RB_{i+1,+1}) + g_{i,j} - 18 (G_{i-1,j} + G_{i+1,j} + 3 * (G_{i,j-1} + G_{i,+1})) \quad (9)$$

By analyzing the parameters of these interpolation models having three R and B colors, it can be seen that the individualized of the compensation for R and B colors are Laplacian filters [9].

The red or blue color modernized pixel  $RB(i, j)$  where its upper and bottom pixels are  $RB(i-1, j)$  and  $RB(i+1, j)$  at  $G(i, j)$  can be calculated as

$$RB_i, (G) = 12 (RB_{i-1,} + RB_{i+1,}) + 12 G_{i,j} - 18 (G_{i-1,j-1} + G_{i-1,+1} + G_{i+1,j-1} + G_{i+1,j+1}) \quad (10)$$

The blue or red color reconstructed pixel  $BR(i, j)$  where its right and left pixels are  $BR(i, j-1)$  and  $BR(i, j+1)$  at  $G(i, j)$  can be computed as shown below

# International Journal of Innovative Research in Science, Engineering and Technology

(An ISO 3297: 2007 Certified Organization)

Vol. 4, Special Issue 6, May 2015

$$BRi, (G) = 12 (BRi,-1 + BRi,j+1) + G - 12 (gi,j-1 + gi,j+1) \quad (11)$$

The parameters of the proposed G, R, and B interpolation equations are intended as 1/2, 1/4, 1/8, and 3/8. It provides a cost-efficient base for VLSI implementation by replacing the multipliers and dividers also with the shifters and adders.

### III. VLSI ARCHITECTURE

In real-time compact disk applications, it is obligatory to develop low computational complexity, low-memory necessity, high performance, and high quality scaling algorithms. The proposed adaptive edge-enhanced scaling algorithm provides a favorable base for VLSI implementation. Fig.4 shows the block diagram of the architecture for the proposed adaptive edge-enhanced scalar. It consists of five main blocks: a register bank, a sharp filter, an edge detector, a simplified bilinear interpolation circuit, and a controller. The details of the register bank are present in Section II B and other parts will be described in the following subsections.

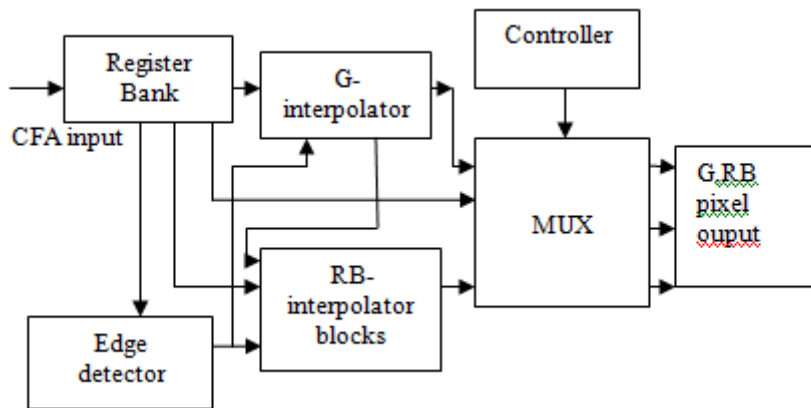

Fig 4 Block diagram of the VLSI architecture for the proposed color interpolation

#### A. Register Bank

The register bank was designed to real-time provide fifteen pixels in CFA format for processing the G interpolator and three RB interpolators during each cycle. It is intended with a two-line-buffer memory and constructed with fifteen shift registers. The projected register bank is designed such that only one value of pixel from memory is received in each cycle time, and then provides fifteen values of CFA pixels as inputs for color interpolation. By adding this register bank, the proposed color interpolation processor achieves the memory access throughout pixel in and pixel out.

#### B. Edge Detector

Fig. 8 shows the architecture of the proposed edge detector. It consists of six absolute sub tractors ( $|Sub|$ ) and five adders (Add). The eight input signals take delivery of their inputs from the register bank. Behind being processed by the edge detector, the values of TD, DH, and DV at the position of P(i, j) are produced for the green color interpolator and the first model of red and blue color interpolator (RB\_M1). In addition, the output signals of the edge detector are in addition sent to the controller. The output signal of TD provides information of the edge intensity. The further two output signals, DH and DV, give the direction in sequence of the edges.

#### C. Interpolation Error

This section briefly introduces the interpolation error theorem and linear interpolation error.

# International Journal of Innovative Research in Science, Engineering and Technology

(An ISO 3297: 2007 Certified Organization)

Vol. 4, Special Issue 6, May 2015

## D. Red and Blue Colors Interpolators

To analyze equations (7), (8), and (9), all input signals should be the same except the values of their parameters. Hence, the reconfigurable technique can be used to design the hardware structural design of the red and blue colors interpolator. It consists of nine adders, one subtractor, two multiplexers, and five shifters. This design can be reconfigured as the functions of Eq. (7), (8), or (9) according to the values of TD, DH, and DV during each processing cycle.

## E. Controller

It provides control signals to the multiplexer for selecting input data for the interpolators and is capable of sending reconfigurable control signals for changing the architecture of the interpolators. Moreover, the controller must monitor its input and output data access with the memory to fit the performance of pixel-in and pixel-out. Finally, the proposed color interpolation processor achieves high performance and high throughput.

## IV. SIMULATION RESULTS

The following figures shows simulated results of color interpolation

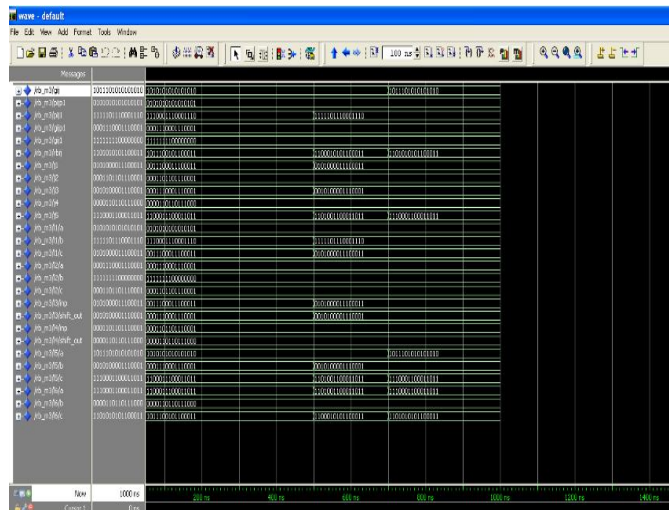
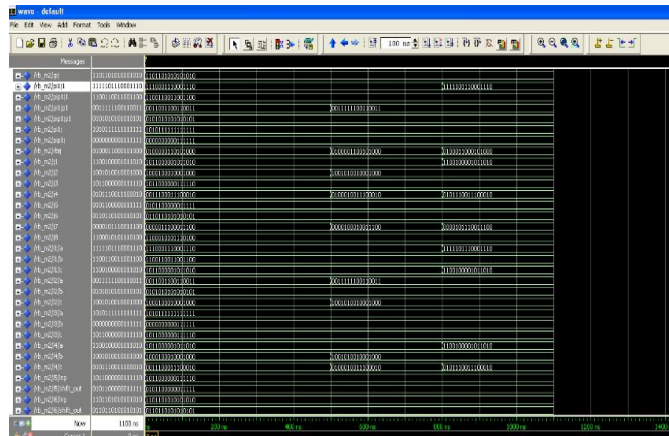

Fig 6 RB-M2

# International Journal of Innovative Research in Science, Engineering and Technology

(An ISO 3297: 2007 Certified Organization)

Vol. 4, Special Issue 6, May 2015

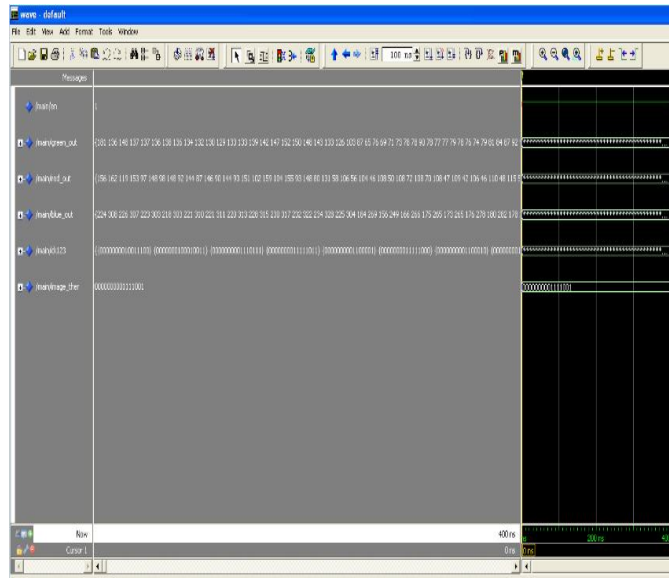

Fig 7 Main output

## IV. CONCLUSION

A novel color interpolation algorithm is proposed to develop a low-cost, low-power, high performance, and high quality color interpolation for real-time video applications. A SPST switch model, an edge detector, clamp and sharpening filters have been used to reduce the power consumption and improve the quality of the images.

Fig 5 RB-M3

## REFERENCES

- [1] B. E. Bayer, "Color Imaging Array," U.S. patent 3 971 065, Jul. 1976.
- [2] H. A. Chang, and H. H. Chen, "Stochastic color interpolation for digital cameras," *IEEE Transaction on Circuits and Systems for Video Technology*, Vol. 17, no. 8, pp. 964-973, Aug. 2007.
- [3] R. Lukac, K. N. Plataniotis, and D. Hatzinakos, "Color image zooming on the Bayer pattern," *IEEE Transaction on Circuits and Systems for Video Technology*, Vol. 15, no. 11, pp. 1475-1492, Nov. 2005.
- [4] S. C. Pei, and I. K. Tam, "Effective color interpolation in CCD color filter arrays using signal correlation," *IEEE Transaction on Circuits and Systems for Video Technology*, Vol. 13, no. 6, pp. 503-513, Jun. 2003.
- [5] B. K. Gunturk, Y. Altunbasak, and R. M. Mersereau, "Color plane interpolation using alternating projections," *IEEE Trans. Image Process.*, vol. 11, no. 9, pp. 997-1013, Sep. 2002.
- [6] X. Li, "Demaosaicing by successive approximation," *IEEE Trans. Image Process.*, vol. 14, no. 3, pp. 370-379, Mar. 2005.
- [7] K. Hirakawa and T. W. Parks, "Adaptive homogeneity-directed demosaicing algorithm," *IEEE Trans. Image Process.*, vol. 14, no. 3, pp. 360-369, Mar. 2005.
- [8] D. Menon, S. Andriani, and G. Calvagno, "Demaosaicing with directional filtering and a posteriori decision," *IEEE Trans. Image Process.*, vol. 16, no. 1, pp. 132-141, Jan. 2007.
- [9] J. Dubois, D. Ginhac, M. Paindavoine, and B. Heyrman, "A 10000 fps CMOS sensor with massively parallel image processing," *IEEE Journal of Solid-State Circuits*, Vol. 43, no. 3, pp. 706-717, Mar. 2008.
- [10] L. Zhang and X. Wu, "Color demosaicking via directional linear minimum mean square-error estimation," *IEEE Trans. Image Process.*, vol. 14, no. 12, pp. 2167-2177, Dec. 2005.
- [11] S. H. Yun, J. H. Kim, and S. Kim, "Color interpolation by expanding a gradient method," *IEEE Trans. Consumer Electronics*, vol. 54, no. 4, pp. 1531-1539, Nov. 2008.
- [12] L. Chang, and Y. P. Tan, "Effective use of spatial and spectral correlations for color filter array demosaicking," *IEEE Trans. Consumer Electronics*, vol. 50, no. 1, pp. 355-365, Feb. 2004.
- [13] C. Y. Su, and Y. S. Lin, "Colour interpolation using wavelet-based classifiers," *Electronics Letters*, vol. 43, no. 12 pp. 667-669, June 2007.
- [14] D. D. Mmuresan and T. W. Parks, "Demaosaicing using optimal recovery," *IEEE Trans. Image Process.*, vol. 14, no. 2, pp. 267-278, Feb. 2005.
- [15] D. Alleysson, S. Süsstrunk, and J. Hérault, "Linear demosaicing inspired by the human visual system," *IEEE Trans. Image Process.*, vol. 14, no. 4, pp. 439-449, Apr. 2005.
- [16] N. X. Lian, L. Chang, Y. P. Tan, and V. Zagorodnov, "Adaptive filtering for color filter array demosaicking," *IEEE Trans. Image Process.*, vol. 16, no. 10, pp. 2515-2525, Oct. 2007.
- [17] K.-H. Chung and Y.-H. Chan, "Color demosaicing using variance of color differences," *IEEE Trans. Image Process.*, vol. 15, no. 10, pp. 2944-2955, Oct. 2006.