

# **Squeezing of Medical Images Using Lifting Based Wavelet Transform coupled with Modified SPIHT Algorithm**

E.Anitha<sup>1</sup>, S.Kousalya Devi<sup>2</sup>

PG Scholar, Applied Electronics, Dept. of ECE, Sri Subramanya college of Engg and Tech, Palani, India<sup>1</sup>

Professor & Head, Dept. of ECE, Sri Subramanya college of Engg and Tech, Palani, India<sup>2</sup>

**ABSTRACT:** Medical images requires huge amount of storage space especially volumetric medical images such as computed tomography (CT) and magnetic resonance (MR) images. The amount of data produced by these techniques is vast and they utilize maximum bandwidth for transmission that often results in degradation of image quality. Image squeezing demands high speed architectures for transformation and encoding process. Medical image squeezing needs compression schemes with faster architectures. A trade-off between speed and area decides the complexity of image compression algorithms. Field Programmable Gate Array (FPGA) technology has become a viable target for the implementation of real time algorithms suitable to image processing applications. FPGAs are the most attractive and popular option, featuring low power and high-performance. This paper proposes a model to obtain a throughput efficient FPGA design and implementation of Lifting Based discrete wavelet transform using folded architecture coupled with modified SPIHT (Set Partition in Hierarchical Trees) algorithm to provide sufficient storage space, area and to visualize power consumption.

**KEYWORDS:** Lifting Scheme, Folded Architecture, Discrete Wavelet Transform, Squeezing, SPIHT,

## **I. INTRODUCTION**

Medical images needs large volume of storage space especially volumetric medical images such as computed tomography (CT), positron emission tomography (PET) images, magnetic resonance (MR) images and ultrasound images. The quantity of data produced by these techniques is enormous and they utilize maximum bandwidth for transmission that often results in degradation of image quality. This might cause a crisis when sending the data for high quality diagnostic applications such as telemedicine, teleradiology and teleconsultation over a network. Also, they are needed to be stored in picture archiving and communication system (PACS) or hospital information system (HIS). It is very tricky for the hospitals to manage the storage facilities for these volumetric images which affects mass storage and fast communication. Thus image detract plays an important role in these applications. Hence squeezing of medical images is an emerging need for storage of medical imaging and for fast communication system.

To optimize the above requirement lifting based wavelet transform coupled with modified SPIHT encoding algorithm gives better squeezing results with good quality of image. During this process, the input image is decomposed into wavelet coefficients using Lifting Based Discrete Wavelet Transform and the resultant form is encoded using SPIHT algorithm with certain modifications based on prior scanning of the coefficients.

## **II. DISCRETE WAVELET TRANSFORM**

Wavelets are a class of functions used to localize a given function in both space and scaling. A discrete wavelet transform (DWT) is any wavelet transform for which the wavelets are discretely sampled. It is a technique to transform image pixels into coefficient values. It decomposes the input into subbands with smaller bandwidths and slower sample rates. Discrete wavelet transforms (DWT) are applied to discrete data sets and produce discrete outputs. It maps the data from the time domain to the wavelet domain. The DWT is being increasingly used for image

## International Journal of Innovative Research in Science, Engineering and Technology

(An ISO 3297: 2007 Certified Organization)

Vol. 4, Special Issue 6, May 2015

compression due to the fact that the DWT supports features like progressive image transmission, ease of compressed image manipulation. DWT considers correlation of images, which translates to better compression.

### A. Lifting Scheme

Digital signals are usually a sequence of integer numbers, while wavelet transforms result in floating point numbers. For an efficient reversible implementation, lifting scheme gains great importance to have a transform algorithm that converts integers to integers. The lifting scheme is a technique for both designing wavelets and performing the discrete wavelet transform. A lifting step can be modified to operate on integers, while preserving the reversibility. A sequence of lifting steps consists of alternating lifts, that is, once the lowpass is fixed and the highpass is changed and in the next step the highpass is fixed and the lowpass is changed. Successive steps of the same direction can be merged. Thus, the lifting scheme became a method to implement reversible integer wavelet transforms.

Constructing wavelets using lifting scheme thus consists of three steps:

1. Split phase, also called Lazy Wavelet transform that split data into odd and even sets.
2. Predict step, in which odd set is predicted from even set. Predict phase ensures polynomial cancellation in high pass.
3. Update phase, which will update even set using wavelet coefficient to calculate scaling function. Update stage ensures preservation of moments in low pass.

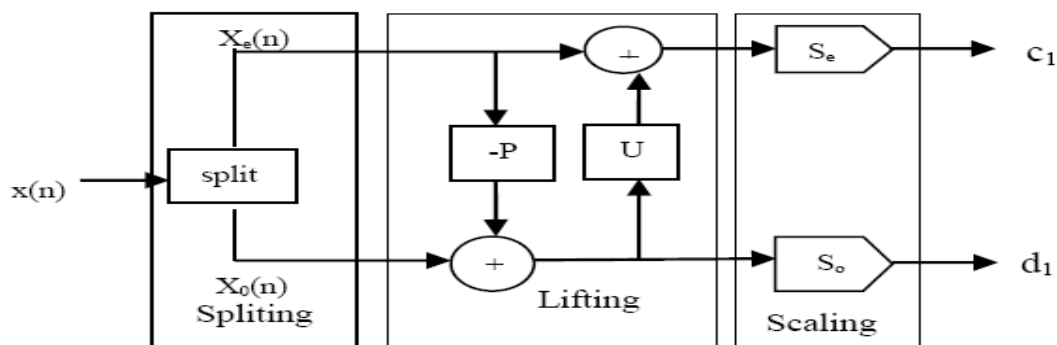

Figure1. Block Diagram of Lifting based Wavelet Transform

Where  $S_e$  and  $S_o$  are normalization factors applied to even and odd parts respectively,  $c_1$  and  $d_1$  are wavelet subbands. After applying all these 4 steps, we get a filtered image that contains only text regions.

### 1) Folded architecture for Lifting Based Wavelet Transform:

The folded structure for Lifting Based Wavelet Transform is another method for the direct mapped architectures in which the lifting-based structures can be designed methodically. In folded structure, the output of the Processing Element (PE) unit is fed back through the delay registers to the Processing Elements input. By adding different numbers of delay registers and coefficients with PE, the structure for different wavelets can be designed.

### 2) Cohen-Daubechies-Feauveau 9/7 (CDF9/7) Wavelet Transform:

It has 7 and 9 taps in the low and high pass analysis filters, respectively. In this mode there are two predict and two update stages. And in each stage the lifting coefficient should be changed. The order of input signal is similar to (5/3) mode, but between two input signals the data is feedback to the circuit from the output.

Filter Coefficients used for the Cohen-Daubechies-Feauveau 9/7 wavelets are :

$$\begin{aligned} \alpha & - -1.586134342 \\ B & - -0.052980118 \\ \Gamma & - 0.882911076 \end{aligned}$$

## International Journal of Innovative Research in Science, Engineering and Technology

(An ISO 3297: 2007 Certified Organization)

Vol. 4, Special Issue 6, May 2015

$\Delta$  - -0.443506852

K - 1.230174105

In Figure 2, M1,M2,M3,M4 represents Multiplier which multiplies Filter Coefficients of Cohen-Daubechies-Feauveau 9/7 wavelet Transform.

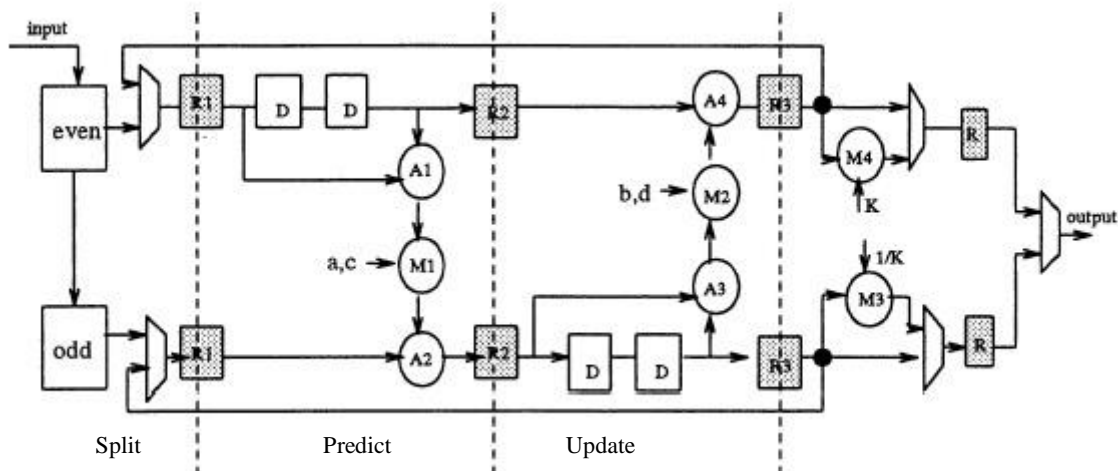

Figure 2. Folded architecture for (9,7) wavelet.

### III. COMPRESSION ALGORITHMS

#### A.SPIHT:

SPIHT is Set Partitioning In Hierarchical Trees. It is the wavelet based compression coder. It divides the wavelet into Spatial Orientation Trees. SPIHT codes a wavelet by transmitting information about the significance of a pixel. It is a method of coding and decoding the wavelet transform of an image.

#### 1.Implementation of SPIHT:

The basic principle is progressive coding which process the image respectively to a lowering threshold. First step, the original image is decomposed into subbands. Then the method finds the maximum iteration number. Second, the method puts the DWT coefficients into a sorting pass that finds the significance coefficients in all coefficients and encodes the sign of these significance coefficients. Third, the significance coefficients that can be found in the sorting pass are put into the refinement pass that uses two bits to exact the reconstruct value for approaching to real value[1]. The result is in the form of a bit stream.

It has three lists to store the values. They are List of Insignificant Pixels (LIP), List of Significant Pixels (LSP), List of Insignificant Sets (LIS).

#### B.MSPIHT:

In SPIHT, the usage of three temporary lists are quite memory consuming. In addition, during coding the elements in the lists are often inserted or deleted, thus, greatly increase the coding time with the expansion of the lists.

Thus Modified SPIHT algorithm varies from SPIHT algorithm by the way in which the subsets are partitioned and significant information is conveyed. In the proposed MSPIHT algorithm, the sorting pass and the refinement pass are combined as one scan pass. The lists LIP and LSP are realized in one RAM module and consequently the area information is stored. According to the characteristic of DWT, if a coefficient is significant at a certain threshold then its neighbors will be significant at the next threshold with a high probability. So we can scan the neighbours of significant coefficients in advance, so that more significant coefficients can be encoded at a specified bit rates.

# International Journal of Innovative Research in Science, Engineering and Technology

(An ISO 3297: 2007 Certified Organization)

Vol. 4, Special Issue 6, May 2015

## 1. Implementation of MSPIHT:

.Modified set partitioning in hierarchical trees is based on prior scanning and ordering the coefficients .The coefficients or sets were sorted according to the number of surrounding significant coefficients before being coded. The previous significant coefficients were refined as soon as the sets around which there existed any significant coefficients had been scanned. The scanning order was confirmed adaptively and did not need any extra storage.

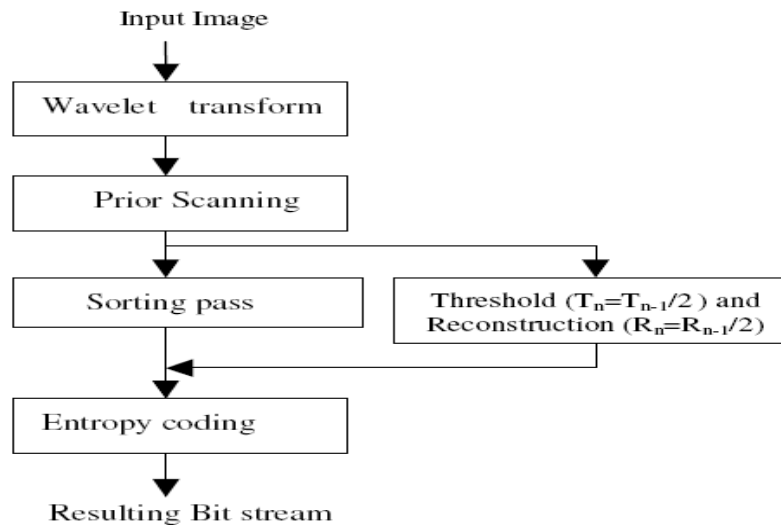

Figure 3. Flow chart for MSPIHT

## IV. SIMULATION OUTPUT

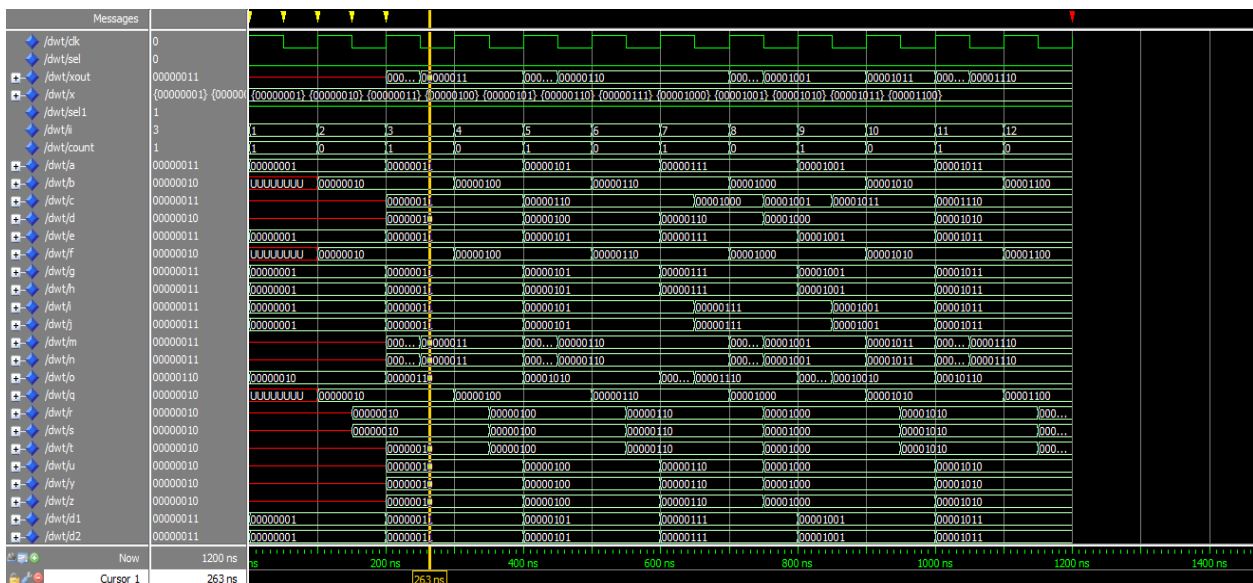

Figure 4: Simulation results Lifting based DWT

The Figure 4 shows the output waveform for Lifting Based Discrete Wavelet transform using Folded Architecture. The Folded architecture uses only limited number resources compared to Direct Architecture which results in efficient area

