

# **Particle Filtering Based LDPC Decoding Algorithm for Hierarchical Modulation Schemes**

G.Manimegalai<sup>1</sup>, A.Kumar<sup>2</sup>

P.G Scholar, Department of ECE, Varuvan Vadivalan Institute of Technology, Dharmapuri, Tamil Nadu, India

Assistant Professor, Department of ECE, Varuvan Vadivalan Institute of Technology, Dharmapuri, Tamil Nadu, India

**ABSTRACT:** In this project, we present a neural network based particle filtering scheme to enhance the LDPC scheme. This is a decoding algorithm preferred for the hierarchical broadcasting systems. Unlike the traditional hierarchical demodulation approaches that suffer from serious interlayer interference (ILI), the proposed method exploits the iterative particle filtering on the decoding section of the secondary layer to mitigate the ILI impairment, there by offering significant gains in reception performance. The algorithm can be applied to different channel coding and mapping schemes under various channel profiles. In addition, the new algorithm has been implemented on a broadband in-band-on-channel digital radio broadcasting system. Numerical results from both simulations and laboratory experiments are provided to quantify the performance advantages of the new algorithm. The performance improvement is shown at least by 2db improvement with respect to a BER of  $10e-5$ . The simulation is performed using Matlab ver 7.12.

## **I. INTRODUCTION**

As a type of error-correcting code, low-density parity check(LDPC) codes were first proposed by Gallager in the early 1960s and revived by Mackay and Neal in 1996. Since then, LDPC codes have attracted wide spread interest in the research community. For LDPC decoding problems, knowing the signal to noise ratio (SNR) is necessary to achieve the best performance. Thus, in many previous studies, the SNR is assumed to be perfectly known prior to decoding. In reality, however, the perfect knowledge of the SNR may not always be available at decoder, as the channel SNR may vary over time. In the presence of an SNR mismatch, the decoding performance of BP can be degraded, and it is more sensitive to the underestimation of SNR than the over estimation. Thus, many decoding algorithms which can perform SNR estimation were proposed to avoid the degradation of decoding performance caused by SNR mismatch.

Wireless mobile communication now demands large data bandwidth to accommodate various multimedia services. The third generation mobile communication, IMT-2000, provides 144 kbps for a fast moving terminal, 384 kbps for walking conditions, and 2 Mbps for stationary conditions. The current bandwidth of IMT-2000 will not be enough to satisfy the various future demands for real-time and high quality service, compared to wired communication services for fast moving stations. The specification of fourth generation (4G) mobile communication is being developed to overcome the 1st limitation. 4G mobile communication is supposed to provide 100 Mbps for a fast moving station and 155 Mbps to 1 Gbps for slow moving and stationary conditions. Such a system requires a very high speed wireless transmission technique.

A wireless channel environment is more subject to noise than a wired channel because the signals are open to external disturbances such as path loss, shadowing, and fading. Therefore, channel coding is inevitable for wireless communication. Channel coding has been an important issue in communication systems. It has the ability to detect and correct errors caused by noise on a channel. The bit-error-rate(BER) can be reduced without increasing the signal power since the transmitted data carry redundancies that are used to detect and correct errors. This coding skill is useful in transmission on finite power channels such as general switched telephone networks.

# International Journal of Innovative Research in Science, Engineering and Technology

(An ISO 3297: 2007 Certified Organization)

Vol. 4, Special Issue 6, May 2015

Low-density parity-check (LDPC) codes [6] proposed by R. G. Gallager in 1962 were too complex to implement and had almost been forgotten in spite of their powerful error-correcting capability. However, it was rediscovered by MacKay and Neal in the 1990s, who made significant improvements on BER performance.

However, the encoding complexity of LDPC codes is still too high, which is a major problem that needs to be solved for their implementation. There have been some studies to reduce the encoding complexity using specially formed matrices such as a lower triangular matrix or semi-random matrix. The encoding process of standard LDPC codes requires transferring a parity check matrix (H) into an equivalent systematic form, which can be accomplished by Gaussian elimination. Gaussian elimination requires large memory and heavy calculation. The encoding process with a semi-random technique is much simpler than that using other matrices because it doesn't require Gaussian elimination. Consequently, a linear time encoding is possible with very little memory.

In this paper, we propose a noise adaptive LDPC decoding scheme that can perform online estimation of the time-varying SNR at the bit-level, where the time-varying SNR satisfies the Chi-square distribution. The key idea of our proposed algorithm is to incorporate a particle filtering (PF) algorithm into BP based LDPC decoding, where the PF estimates the posteriori probability distribution of noise variance of each code bit by sampling a list of random particles with associated weights. Generally, the standard BP algorithm cannot handle the situation when variables are continuous or the number of variable labels is huge, e.g. the continuous SNR change in an AWGN channel. Thus, the integration of PF and BP provides a way for BP to handle continuous variables.

## II. EXISTING WORK & ITS ANALYSIS

### EXISTING WORK:

Earlier literatures concentrate on the structured decoding of LDPC. Chung and others showed that the threshold for an LDPC code of code rate  $\frac{1}{2}$  on an additive white Gaussian noise (AWGN) channel was within 0.0045 Db of the Shannon limit, and simulation results were within 0.04 Db of the Shannon limit at a BER of  $10^{-6}$  using a block length of 107. Compared with turbo codes, the LDPC codes exhibit better performance due to good distance properties and less complex and highly parallelizable decoding approaches. Therefore, the LDPC codes have been widely considered as next generation error-correcting codes for telecommunication. DVB-S2, the new European satellite broadcasting system, also employs a concatenated code composed of a LDPC code and BCH code.

In [4], a simple estimator of the unknown SNR in Turbo decoding was proposed, which is based on the sums of squared receiver values and sums of their absolute values. Ramon *et al.* presented an EM-based estimation of the carrier phase, amplitude and noise variance in multiuser turbo receivers in [6].

In [4] and [6], it was found that the channel state information extracted by their proposed estimator effectively improved the decoding performance. However, in the above studies it was all assumed that the SNR is fixed within each codeword block. In practice, in many communication systems such as orthogonal frequency division multiplexing (OFDM) and synchronous code-division multiple-access (CDMA) systems, noise varies with time quickly (e.g. within each codeword block). The papers [7] and [8] consider a randomly varying noise variance according to the Chi-square distribution in OFDM and CDMA systems, respectively. Similar to the aforementioned works, these two studies also assume that noise variances are the same for all subcarriers. However, it is possible to consider the change of SNR differs in bit-level for each codeword block. Although one may argue that the actual SNR may be able to be obtained through a pilot signal or feedback channel under varying channel conditions, a fast varying channel implies potentially a large communication overhead if we want to take full advantage of the channel state information.

In [10], the implementations of particle methods as message passing were studied. Other PF algorithms for decoding LDPC codes and related codes were also described. Moreover, PF algorithms for channel equalization, estimation, tracking and synchronization are investigated.

# International Journal of Innovative Research in Science, Engineering and Technology

(An ISO 3297: 2007 Certified Organization)

Vol. 4, Special Issue 6, May 2015

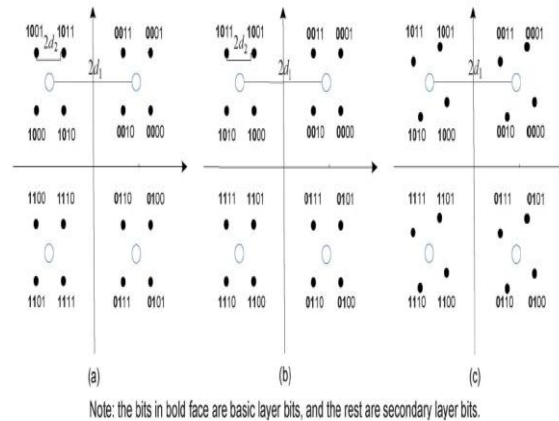

Different constellations and mappings for the QPSK+QPSK HM signal.

## Structure-Based Decoding

The structure-based decoder is motivated by the following observation. In QAM-based HM broadcasting, the modulation scheme of each layer (for basic and secondary information) is sent over a control channel. As a result, the QAM structure information<sup>2</sup> is available for the demodulation/decoding of both layers. In particular, as shown in Fig. 2, the receiver has prior knowledge of the secondary-layer modulation scheme when demodulating/decoding the basic layer. This extra information can be used to modify the LLR of the basic-layer coded bits. (In traditional HM reception, the QAM demodulators simply calculate the LLR by assuming that the interference is Gaussian distributed; the resulting LLR is then fed into the LDPC decoder.) Accordingly, the new receiver for the basic layer is comprised of two parts: a structure-based detector, which produces modified soft information in the form of LLR, and a SISO LDPC decoder that incorporates the LLR. The structure-based detector has two inputs: One of which is the second layer structure information, whereas the other is the  $k$ th received symbol, which can be expressed as

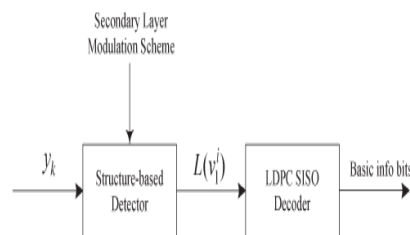

$$y_k = \sqrt{P_1}x_1^k + \sqrt{P_2}x_2^k + n_k.$$

In addition to  $y_k$ , the modulation scheme and, consequently, the distribution function of  $x_2$ , are also known to the detector.

$$y_k = \sqrt{P_1}x_1^k(v_1^1, \dots, v_1^{l_1}) + \sqrt{P_2}x_2^k(v_2^1, \dots, v_2^{l_2}) + n_k.$$

# International Journal of Innovative Research in Science, Engineering and Technology

(An ISO 3297: 2007 Certified Organization)

Vol. 4, Special Issue 6, May 2015

Unlike the traditional QAM demodulators, which calculate the LLR only based on the observation  $y_k$ , the structure-based detector produces the refined LLR soft information by accounting for the mapping information (12 bits are mapped into a symbol) in the secondary layer.

For additive white Gaussian noise (AWGN) channels, the modified LLR value for the  $i$ th bit of  $x_k^1$  can be expressed as

$$L(v_1^i) = \log \frac{P[v_1^i = 0 | y_k; \text{mapping information on } x_2^k]}{P[v_1^i = 1 | y_k; \text{mapping information on } x_2^k]}$$

$$= \log \frac{\sum_{(v_2^1, \dots, v_2^{l_2}) \in \{0,1\}^{l_2}} P[v_1^i = 0 | y_k, v_2^1, \dots, v_2^{l_2}] P(v_2^1, \dots, v_2^{l_2})}{\sum_{(v_2^1, \dots, v_2^{l_2}) \in \{0,1\}^{l_2}} P[v_1^i = 1 | y_k, v_2^1, \dots, v_2^{l_2}] P(v_2^1, \dots, v_2^{l_2})}$$

$$= \log \frac{\sum_{(v_2^1, \dots, v_2^{l_2}) \in \{0,1\}^{l_2}} \exp(-D(v_1^i = 0; v_2^1, \dots, v_2^{l_2}))}{\sum_{(v_2^1, \dots, v_2^{l_2}) \in \{0,1\}^{l_2}} \exp(-D(v_1^i = 1; v_2^1, \dots, v_2^{l_2}))}$$

where,

$$D(v_1^i = 0; v_2^1, \dots, v_2^{n_2}) \doteq \frac{1}{2\sigma^2} \times \left\| y_k - \sqrt{P_2} x_2^k(v_2^1, \dots, v_2^{n_2}) - \sqrt{P_1} x_1^k(v_1^1, \dots, v_1^{i-1}, 0, v_1^{i+1}, \dots, v_1^{n_1}) \right\|^2$$

$$D(v_1^i = 1; v_2^1, \dots, v_2^{n_2}) \doteq \frac{1}{2\sigma^2} \times \left\| y_k - \sqrt{P_2} P x_2^k(v_2^1, \dots, v_2^{n_2}) - \sqrt{P_1} x_1^k(v_1^1, \dots, v_1^{i-1}, 1, v_1^{i+1}, \dots, v_1^{n_1}) \right\|^2$$

### III. PROPOSED WOR

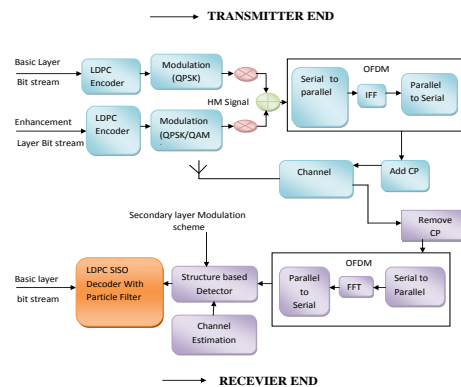

In our scheme, we consider binary LDPC codes over an AWGN channel with a hierarchical modulation. Suppose an input  $X$  takes values  $\pm 1$  and the output is  $Y = X + Z$ , where  $Z$  is a Gaussian random variable  $N(0, \sigma^2)$ , and  $\sigma^2$  evolves over time in bit-level. We show that the proposed algorithm no longer depends on the initial estimation of noise

# International Journal of Innovative Research in Science, Engineering and Technology

(An ISO 3297: 2007 Certified Organization)

Vol. 4, Special Issue 6, May 2015

variance, and it offers a lower decoding error rate than the traditional BP decoding. In this paper, the belief of each particle, generated by the BP algorithm, is used to update the weights in PF directly, hence reducing the complexity of the weights update. Furthermore, in the PF algorithm, we compare two different particle moving methods, the Random Walk(RW) algorithm and the Metropolis-Hasting (MH) algorithm, which are used to perturb the congested particles after resampling. We find that the BP algorithm based on PF using the MH algorithm achieves a better decoding performance than the counterpart using the RW algorithm. The detailed description of particle filtering is given in forthcoming chapters

## IMPLEMENTATION

### NOISE ADAPTIVE LDPC DECODING

The main idea of noise adaptive LDPC decoding with PF is illustrated in the factor graph of Fig. 1 with three regions, where all circle nodes denote variable nodes and all square nodes denote factor nodes. If an accurate estimation of the noise variance  $\sigma^2$  is given, the standard BP algorithm can obtain a good decoding performance by exchanging messages within Region 3. In Region 3, factor node  $a = A, \dots, M$  corresponding to  $f_a$ , connects the bit variable node of  $x_i, i = 1, 2, \dots, N$  and takes into account the constraints imposed by the LDPC codes. The corresponding factor function  $f_a$  is given by

$$f_a(\mathbf{x}_a) = \begin{cases} 1 & \text{if even number of 1's in arguments} \\ 0 & \text{otherwise} \end{cases} \quad (1)$$

where  $\mathbf{x}_a$  indicate all variables connecting to factor node of  $f_a$ , that is  $\mathbf{x}_a = (x_i | i \in \mathcal{M}(a))$ , and  $\mathcal{M}(a)$  represents the set of neighbors for a node  $a$ . Now, assuming that the noise variance is changing with time, we can model this using extra variable nodes corresponding to  $\sigma_1, \sigma_2, \dots, \sigma_N$ , which are shown as circles in Region 1. For each variable node of  $\sigma_i$  in Region 1, we model it with  $N_p$  particles, which are labeled as  $\sigma_i^1, \dots, \sigma_i^{N_p}$ . Then these particles are used to estimate the noise variance with the PF algorithm. Additionally, Region 1 and Region 3 are connected by factor nodes of  $f_i$  in Region 2, and the factor functions are defined as

$$f_i(\hat{x}_i, \sigma_i^k; y_i) = \frac{1}{\sigma_i^k} e^{-\frac{(y_i - \hat{x}_i)^2}{(\sigma_i^k)^2}} \quad (2)$$

where  $y_i$  and  $\hat{x}_i$  are the  $i$ -th input codeword and candidate codeword respectively, and the variables  $i = 1, 2, \dots, N$  and  $k = 1, 2, \dots, N_p$ . Furthermore, the correlation between adjacent variable nodes is represented by additional factor node of  $f_{i,i+1}$  in Region 1, where the corresponding factor function is defined as

$$f_{i,i+1}(\sigma_i^k, \sigma_{i+1}^k) = e^{-\frac{(\sigma_{i+1}^k - \sigma_i^k)^2}{\lambda_{i,i+1}}} \quad (3)$$

where  $\lambda_{i,i+1}$  is a parameter to reflect the correlation between adjacent variable nodes. Generally, a small  $\lambda_{i,i+1}$  means a strong correlation, while a large  $\lambda_{i,i+1}$  reflects a weak/independent correlation. Moreover, the value of  $\lambda_{i,i+1}$  can be estimated simultaneously with decoding.

### Belief Propagation based on Particle Filtering

The BP algorithm, which estimates marginal probabilities by exchanging the message between adjacent neighboring nodes, can only handle discrete variables. The noise variance  $\sigma^2$  in the channel, however, is not discrete in

## International Journal of Innovative Research in Science, Engineering and Technology

(An ISO 3297: 2007 Certified Organization)

Vol. 4, Special Issue 6, May 2015

general. Nonetheless, by incorporating PF with BP, we are able to extend BP to handle continuous variables

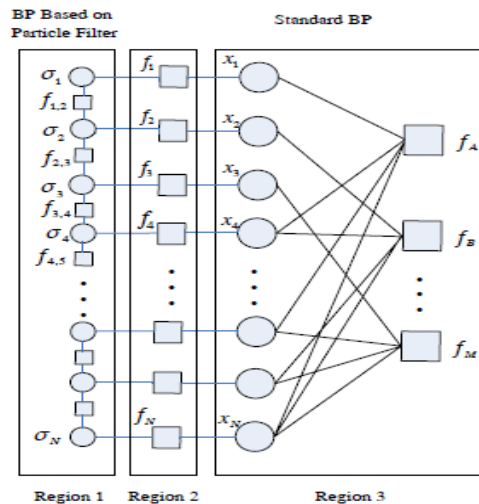

Fig1: Factor graph of belief propagation based on PF.

In our scheme, the key idea is to sample  $N_p$  particles  $\sigma_i^1, \dots, \sigma_i^{N_p}$  with associated weights for each variable node of  $\sigma_i$  in Region 1. Note that these changes do not affect the message update rules described in the standard BP algorithm. However, the location and corresponding weight of each particle  $\sigma_i^k$  have to be adjusted over time. In our algorithm, the belief  $b(\sigma_i^k)$  of each particle is proportional to the particle weight  $\omega_i^k$ . Thus the update of particle weight is achieved by updating the belief of variable nodes using BP. According to the rule of concentrating on particles with large weight and discarding particles with negligible weight, locations of particles are adjusted through systematic resampling (SR) algorithm and RW / MH algorithm. Finally, all weights are reset to a uniform weight for further estimation.

The detailed workflow of the PF based BP algorithm is described as follows.

1) At the initial step, for each variable node in Region

1, we initialize each particle value  $(\sigma_i^k)^2$  to  $(\hat{\sigma})^2$  and weight  $\omega_i^k$  to  $\frac{1}{N_p}$ , where the choice of  $(\hat{\sigma})^2$  does not significantly influence the performance of our PF based algorithm.

2) Then  $N_p$  new samples,  $\tilde{\sigma}_i^1, \dots, \tilde{\sigma}_i^{N_p}$  will be drawn with probabilities proportional to  $\omega_i^k$  using system at resampling. As a result, some  $\sigma_i^k$  that have small probabilities will likely be discarded whereas those with high probability will be repeatedly drawn.

3) To maintain the diversity of the particles, the new particle locations will be perturbed by the RW algorithm or the MH algorithm. The MH algorithm adds a decision step to retain or reject the proposed value generated by the RW algorithm. Thus, the MH algorithm improves the convergence behavior comparing to the standard Gaussian RW algorithm.

4) Based on the new particles, update messages using the standard BP algorithm and compute the corresponding belief for each variable node.

5) Check if the estimated codeword satisfies the check specified by the parity check matrix  $H$ . If the condition is satisfied, the algorithm is completed; otherwise, go to step 2. Our algorithm stops either when it finds a valid codeword or when it reaches the maximum number of iterations.

# International Journal of Innovative Research in Science, Engineering and Technology

(An ISO 3297: 2007 Certified Organization)

Vol. 4, Special Issue 6, May 2015

## IV. EXPECTED OUTPUTS

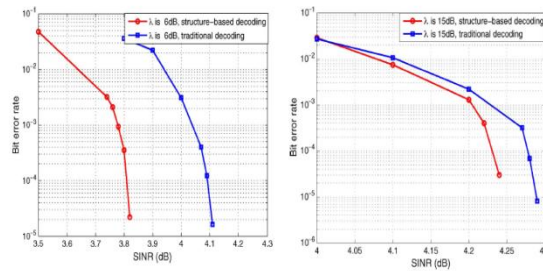

Let  $\lambda$  be the power ratio between the basic-layer signal and the secondary-layer signal as follows:

$$\lambda = \frac{P_1}{P_2} \quad (2)$$

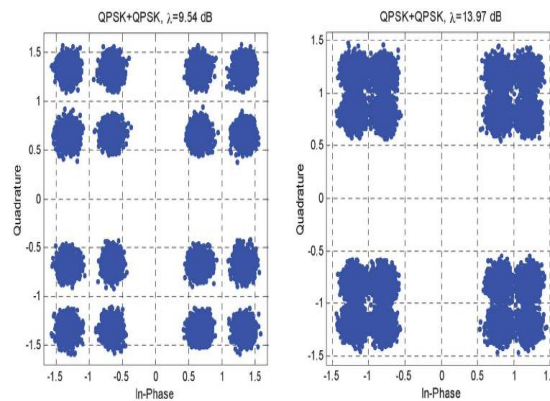

## V. CONCLUSION

By exploiting the structure information on the secondary layer, the proposed decoding algorithm effectively mitigates the ILI for the basic layer in HM reception without decoding the other layers. Numerical results from simulations and a real-world digital radio broadcasting system are provided to illustrate the efficacy of the proposed technique. In this phase the literatures on the previous works related to the project, LDPC codes, hierarchical modulation, matlab software, communication toolbox in matlab are studied .

## REFERENCES

- [1] R. Gallager, "Low-density parity-check codes," *IEEE Trans. Inf. Theory*, vol. 8, no. 1, pp. 21-28, 1962.
- [2] D. J. C. MacKay and R. M. Neal, "Near Shannon limit performance of low density parity check codes," *Electron. Lett.*, vol. 32, no. 18, 1996.
- [3] W. Tan and J. R. Cruz, "Signal-to-noise ratio mismatch for low density parity-check coded magnetic recording channels," *IEEE Trans. Magnetics*, vol. 40, no. 2, pp. 498-506, 2004.
- [4] T. A. Summers and S. G. Wilson, "SNR mismatch and online estimation in turbo decoding," *IEEE Trans. Commun.*, vol. 46, pp. 421-423, 1998.
- [5] H. Saeedi and A. Banihashemi, "Performance of belief propagation for decoding LDPC codes in the presence of channel estimation error," *IEEE Trans. Commun.*, vol. 55, no. 1, pp. 83-89, 2007.
- [6] V. Ramon, C. Herzet, L. Vandendorpe, and M. Moeneclaey, "EM algorithm-based estimation of amplitude, carrier phase and noise variance in multiuser turbo receivers," in *Proc. ISSSTA*, 2004, pp. 550-554.
- [7] X. Wei and T. Weber, "MMSE detection based on noise statistics with random noise variance," in *Proc. IEEE 68th Veh. Technol. Conf.*, 2008, pp. 1-5.
- [8] X. Wang and R. Chen, "Adaptive Bayesian multiuser detection for synchronous CDMA with Gaussian and impulsive noise," *IEEE Trans. Signal Process.*, vol. 47, no. 7, p. 2013, 2000.
- [9] A. Doucet and N. De Freitas, *Sequential Monte Carlo Methods in Practice*. Springer Verlag, 2001.
- [10] J. Dauwels, S. Korf, and H. A. Loeliger, "Particle methods as message passing," in *Proc. IEEE Int. Symp. Inf. Theory*, 2006, pp. 2052-2056.