

International Journal of Innovative Research in Science, Engineering and Technology

(An ISO 3297: 2007 Certified Organization)

Vol. 4, Special Issue 6, May 2015

Control Techniques for Trinary Multilevel Inverter

M.Nandhini¹, D.Periyaazhagar², G.Irusapparajan³,

PG Scholar, Department of EEE, Arunai Engineering College, Thiruvannamalai, Tamilnadu, India¹.

Asst Professor, Department of EEE, Arunai Engineering College, Thiruvannamalai, Tamilnadu, India²

Professor, Department of EEE, Mailam Engineering College, Mailam, Tamilnadu, India³

ABSTRACT: This paper proposes a new trinary Multilevel Inverter. This MLI produce a twenty Seven level output from a unequal dc source. It operates in Asymmetrical mode with various Advanced PWM strategies. The various Advanced PWM techniques include Trapezoidal and Triangular modulation. Various type of a carrier arrangement are Unipolar Phase Disposition (UPD), Unipolar Alternative Phase Opposition Disposition (UAPOD) and Unipolar Carrier Overlapping (UCO). The simulation of proposed circuit is carried out by using MATLAB/SIMULINK. From the Analysis Total Harmonic Distortion (THD) was highly reduced.

KEYWORDS: MLI, THD, USPWM, UPD, UAPOD, UCO.

I.INTRODUCTION

Multilevel inverter are a source of high power, often used in industrial applications. MLI having more advantage when compared to the conventional two level inverter. Masaoud, a. hew Wooi ping [1] introduce a new control method of three phase MLI. Johannes Kolb, Felix Kammerer, Mario Gommeringer, and Michael Braun[2] proposes a new Cascaded Control System of the Modular Multilevel Converter to reduce voltage pulsation. Yuhei Okazaki, Makoto Hagiwara, and Hirofumi Akagi [3] discussions on a practical speed-sensor less start-up method for an induction motor driven by a modular multilevel cascade inverter based on double-star chopper cells (MMCI-DSCC). Yousefpoor.n, Babaei.S [4] proposes a total harmonic distortion minimization technique in MLI. ObradDordevic, Martin Jones, and Emil Levi,A [5] Compares various Carrier-Based and Space Vector PWM Techniques for Three-Level Five-Phase Voltage Source Inverters. Raju.s, Mohan.n[6] introduce a constant pulse with modulation technique. EbrahimBabaei, SomayehAlilu, Sara Laali [7] introduces a New General Topology for Cascaded Multilevel Inverters with Reduced Number of Components Based on Developed H-Bridge. Sumit K. Chattopadhyay, and Chandan Chakraborty [8] proposes a New Multilevel Inverter Topology with Self-Balancing Level Doubling Network. Bahr Eldin S. Mohammed and K.S.Rama Rao [9] develops New Multicarrier Based PWM for Multilevel Converter. Mariusz Malinowski, K.GopaKumar, Jose Rodriguez and Marcelo A.Perez[10] proposes Survey on Cascaded Multilevel Inverters. Batschauer, A.L., Mussa, S.A., and Heldwein, M.L [11] introduce Three Phase Hybrid Multilevel Inverter Based on Half Bridge Modules. AlirezaNami, FiruzZare, Arindam Ghosh and FredeBlaabjerg [12] invented Hybrid Cascade Converter Topology With Series-Connected Symmetrical and Asymmetrical Diode-Clamped H-Bridge Cells. AlirezaNami, FiruzZare, Arindam Ghosh and FredeBlaabjerg [12] develops Hybrid Cascade Converter Topology With Series-Connected Symmetrical and Asymmetrical Diode-Clamped H-Bridge Cells. Jing Zhao, Yunlong Han, Xiangning He, Cheng Tan, Jun Cheng, and Rongxiang Zhao [13] introduce a Multilevel Circuit Topologies Based on the Switched-Capacitor Converter and Diode-Clamped Converter. Jeffrey Ewanchuk, John Salmon, and BehzadVafakha [14] proposes a Five-/Nine-Level Twelve-Switch Neutral-Point-Clamped Inverter for High-Speed Electric Drives. Robert Stala [15] develops Application of Balancing Circuit for DC-Link Voltages Balance in a Single-Phase Diode-Clamped Inverter with Two Three-Level Legs. This paper presents a three phase twenty seven level inverter topology for various SPWM switching techniques. Simulations were performed using MATLAB-SIMULINK. Harmonics analysis and different performance parameter was measured and displayed below.

International Journal of Innovative Research in Science, Engineering and Technology

(An ISO 3297: 2007 Certified Organization)

Vol. 4, Special Issue 6, May 2015

II. ASYMMETRIC MULTILEVEL INVERTER

However, it is possible to have different voltage levels among the cells, and the circuit can be called as asymmetric trinary multilevel inverter. Depending on the availability of dc sources, the voltage levels are not limited to a specific ratio. This feature allows more levels to be created in the output voltage, and thus reduces the harmonic contents with less number of cascaded cells required.

III. PROPOSED MULTILEVEL INVERTER

This paper introduces a new trinary three phase multilevel inverter. Among these Fig 1 shows single phase multilevel inverter. For each phase consists of three cells and containing three different source and twelve switches. Based on switching condition MLI will produce different level output (twenty seven level).

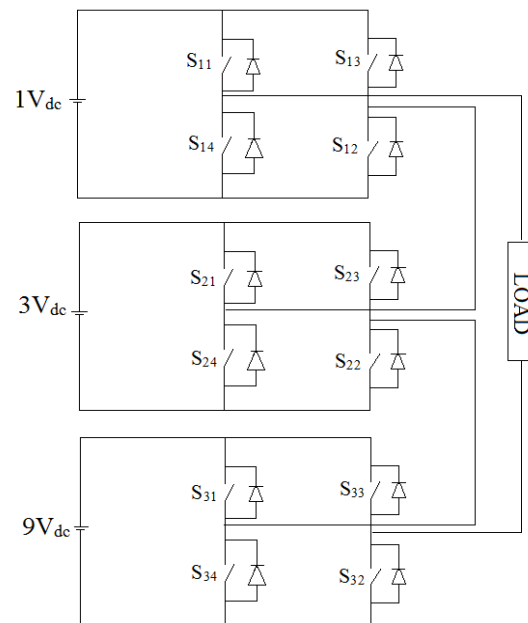

Fig 1: Circuit diagram for single phase MLI

IV. ADVANCED PWM TECHNIQUES

In this paper modified trapezoidal and triangular wave is used as a reference signal and triangular wave is used as carrier signal. By comparing these two signals the output is given to MLI switch as a triggering pulse. In this technique carrier having same peak-peak amplitude and reference signal having the same frequency. The various Advanced PWM techniques are given below

- i. Trapezoidal Modulation
- ii. Triangular Modulation

Here carrier was arranged by using the following strategy

- a. Phase Disposition (PD)
- b. Alternative Phase Opposition Disposition (APOD)
- c. Carrier Overlapping (CO)

i. Trapezoidal Modulation Technique

In this modulation technique Trapezoidal wave is used as reference signal and triangular wave is used as a carrier signal.

International Journal of Innovative Research in Science, Engineering and Technology

(An ISO 3297: 2007 Certified Organization)

Vol. 4, Special Issue 6, May 2015

a. Unipolar Phase disposition PWM strategy.

Fig: 2 show the carrier arrangement of UPD technique. In this PD technique all the carrier are arranged in phase with each other.

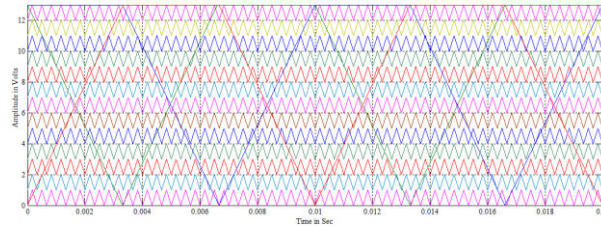

Fig: 2 Carrier arrangements for UPD Strategy

b. Unipolar Alternate phase opposition disposition PWM strategy

Fig: 3 show the carrier arrangement of UAPOD technique. In case of APOD technique carrier are arranged in 180 out of phase with the neighbor carrier.

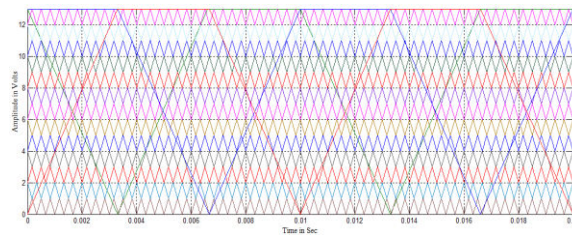

Fig: 3 Carrier arrangements for UAPOD Strategy

c. Unipolar Carrier overlapping PWM strategy

Fig: 4 show the carrier arrangement of UCO technique. In CO technique each carrier are overlapp with other carrier. By comparing the reference signal with carrier signal it will produce a triggering pulse.

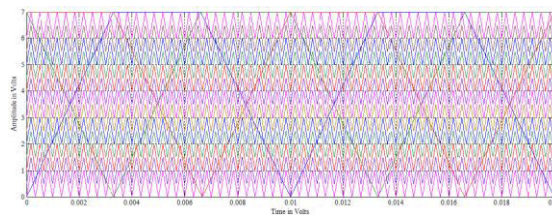

Fig: 4 Carrier arrangements for UCO Strategy

ii. Triangular Modulation

In this modulation technique Triangular wave is used as both reference signal and carrier signal.

a. Unipolar Phase disposition PWM strategy.

Fig: 4 show the carrier arrangement of UPD technique. In this PD technique all the carrier are arranged in phase.

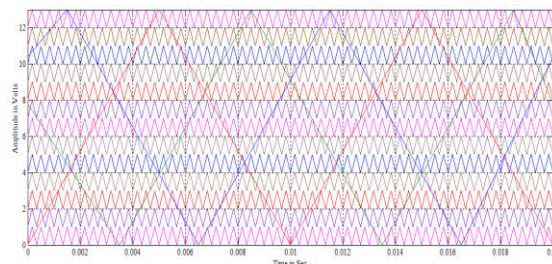

Fig: 5 Carrier arrangements for UPD Strategy

International Journal of Innovative Research in Science, Engineering and Technology

(An ISO 3297: 2007 Certified Organization)

Vol. 4, Special Issue 6, May 2015

b. Unipolar Alternate phase opposition disposition PWM strategy

Fig: 6 show the carrier arrangement of UAPOD technique. In case of APOD technique carrier are arranged in 180 out of phase with the neighbor carrier.

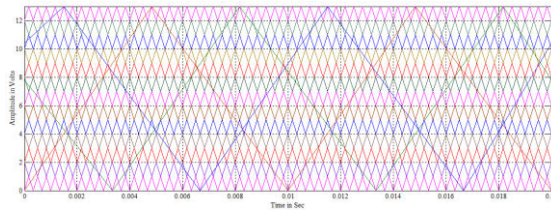

Fig: 6 Carrier arrangements for UAPOD Strategy

c. Unipolar Carrier overlapping PWM strategy

Fig: 7 show the carrier arrangement of UCO technique. In CO technique each carrier are overlapp with other carrier. By comparing the reference signal with carrier signal it will produce a triggering pulse.

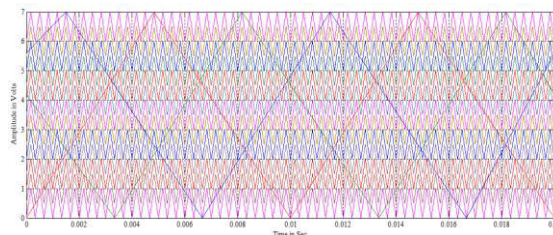

Fig: 7 Carrier arrangements for UCO Strategy

V. SIMULATION RESULTS

The Three phase Twenty seven level inverter is modelled in SIMULINK using power system block set. Switching signals for three phase multilevel inverter using Advanced PWM techniques are simulated. Simulations are performed for different values of m_a ranging from 0.95 to 1 and the corresponding %THD are measured using the FFT block and their values are shown in Table.

Trapezoidal Modulation

Figure 8 to13 shows the simulated output voltage of three phase MLI and their corresponding FFT plot. Figure 8 shows the twenty seven level output voltage generated by UPDPWM switching strategy and its FFT plot is shown in Figure 9. Figure 10 shows the twenty seven level output voltage generated by UAPODPWM switching strategy and its FFT plot is shown in Figure 11. Figure 12 shows the twenty seven level output voltage generated by UCOPWM strategy and its FFT plot is shown in Figure 13. Tables I to IV show the %THD, V_{RMS} (fundamental of the output voltage), Form Factor (FF) and Crest Factor (CF) for various modulation indices of three phase MLI.

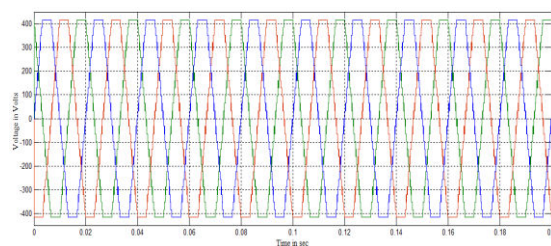

Fig: 8 Twenty seven Level output voltage generated by UPD strategy

International Journal of Innovative Research in Science, Engineering and Technology

(An ISO 3297: 2007 Certified Organization)

Vol. 4, Special Issue 6, May 2015

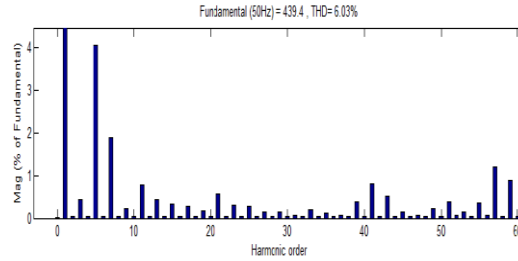

Fig: 9 FFT plot generated by UPD strategy

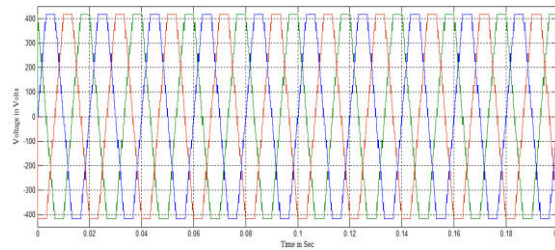

Fig: 10 Twenty seven Level output voltage generated by UAPOD strategy

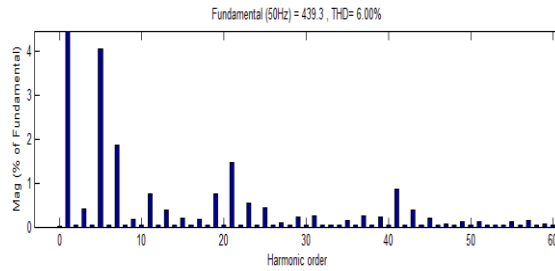

Fig: 11 FFT plot generated by UAPOD strategy

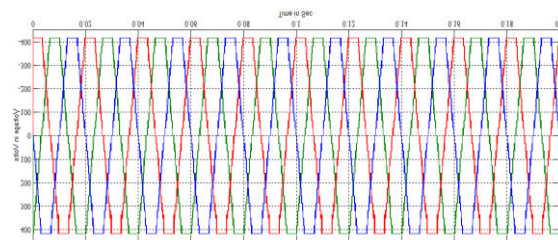

Fig: 12 Twenty seven Level output voltage generated by UCO strategy

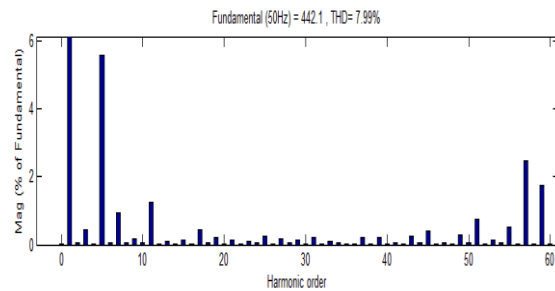

Fig: 13 FFT plot generated by UCO strategy

International Journal of Innovative Research in Science, Engineering and Technology

(An ISO 3297: 2007 Certified Organization)

Vol. 4, Special Issue 6, May 2015

Table I: % THD for Different Modulation Indices

Ma	UPD	UAPOD	UCO
1	6.03	6.00	7.96
0.95	6.96	6.90	8.59

Table II: V_{RMS} (Fundamental) For Different Modulation Indices

ma	UPD	UAPOD	UCO
1	310.7	311.7	312.5
0.95	295.4	295.3	301.3

Table III: Form Factor for Different Modulation Indices

ma	UPD	UAPOD	UCO
1	3767.887	3016.504	3856.596
0.95	3525.059	3033.696	4281.654

Table IV: Crest Factor for Different Modulation Indices

ma	UPD	UAPOD	UCO
1	1.41422	1.4139	1.41423
0.95	1.41401	1.41415	1.41452

Triangular Modulation

Fig 14 to19 shows the simulated output voltage of three phase MLI and their corresponding FFT plot. Figure 14 shows the twenty seven level output voltage generated by UPDPWM switching strategy and its FFT plot is shown in Figure 15. Figure 16 shows the twenty seven level output voltage generated by UAPODPWM switching strategy and its FFT plot is shown in Figure 17. Figure 18 shows the twenty seven level output voltage generated by UCOPWM strategy and its FFT plot is shown in Figure 19. Tables V to VIII show the %THD, V_{RMS} (fundamental of the output voltage), Form Factor (FF) and Crest Factor (CF) for various modulation indices of three phase MLI.

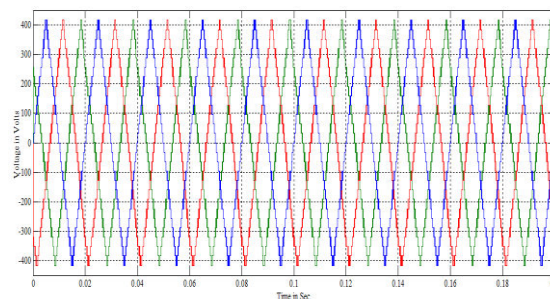

Fig: 14 Twenty seven Level output voltage generated by UPD strategy

International Journal of Innovative Research in Science, Engineering and Technology

(An ISO 3297: 2007 Certified Organization)

Vol. 4, Special Issue 6, May 2015

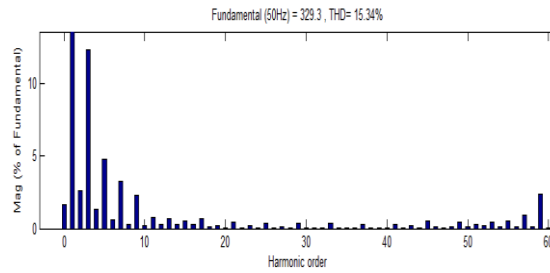

Fig: 15 FFT plot generated by UPD strategy

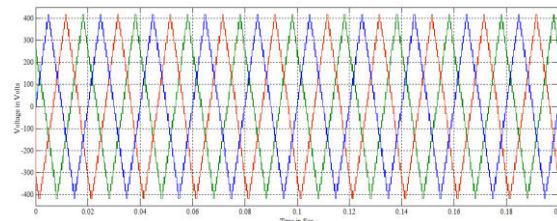

Fig: 16 Twenty seven Level output voltage generated by UAPOD strategy

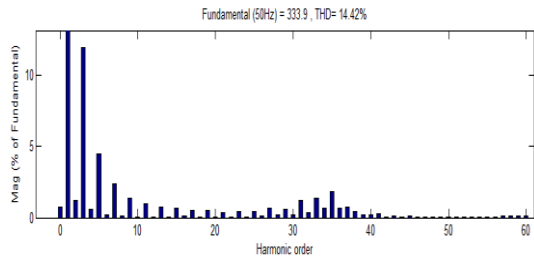

Fig: 17 FFT plot generated by UAPOD strategy

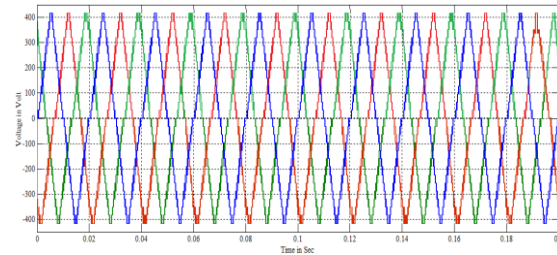

Fig: 18 Twenty seven Level output voltage generated by UCO strategy

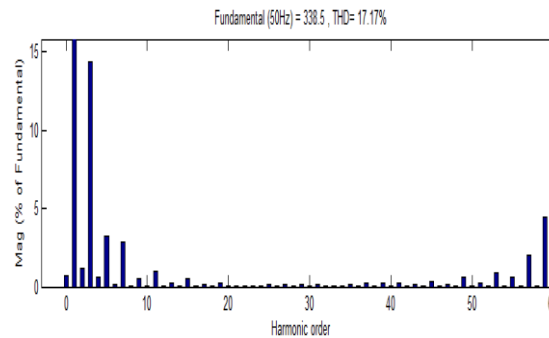

Fig: 19 FFT plot generated by UCO strategy

International Journal of Innovative Research in Science, Engineering and Technology

(An ISO 3297: 2007 Certified Organization)

Vol. 4, Special Issue 6, May 2015

Table V: % THD for Different Modulation Indices

ma	UPD	UAPOD	UCO
1	15.34	14.42	17.19
0.95	14.89	14.20	16.02

Table VI: V_{RMS} (Fundamental) For Different Modulation Indices

ma	UPD	UAPOD	UCO
1	329.3	333.9	338.5
0.95	315.5	319.3	328.5

Table VII: Form Factor for Different Modulation Indices

ma	UPD	UAPOD	UCO
1	43.69	94.81	95.15
0.95	45.12	93.77	85.91

Table VIII: Crest Factor For Different Modulation Indices

ma	UPD	UAPOD	UCO
1	1.4139	1.4142	1.4139
0.95	1.4146	1.4141	1.4141

VI.CONCLUSION

In this paper, a Newtrinary multilevel inverter have been developed using MATLAB/SIMULINK. A proposed asymmetric multilevel inverter gives higher output voltage level. The Performance parameters like %THD, V_{rms} , CF and FF have been analysed and presented. In that both trapezoidal and triangular modulation having lower % THD in UAPOD techniques and V_{rms} is higher in UCO.

REFERENCES

- [1] Masaoud, A. Hew Wooi Ping, Mekhilef.s, Taallah,"New Three-Phase Multilevel Inverter With Reduced Number of Power Electronic Components",IEEE Transactions on Power Electronics,Vol-29, pp 6018-6029, July 2014.
- [2] Johannes Kolb, Felix Kammerer, Mario Gommeringer, and Michael Braun, "Cascaded Control System of the Modular Multilevel Converter for Feeding Variable-Speed Drives", IEEE Transactions On Power Electronics, Vol. 30, No. 1,Pp 349-357, January 2015
- [3] Yuhei Okazaki, Makoto Hagiwara, and Hirofumi Akagi," A Speed-Sensorless Start-Up Method of an Induction Motor Driven by a Modular Multilevel Cascade Inverter(MMCI-DSCC)" IEEE Transactions On Industry Applications, Vol. 50, No. 4, Pp 2671-2680,july/August 2014.
- [4] Yousefpoor, N. ; Parkhideh, B. ; Babaei, S. ; Bhattacharya, S.Control of cascaded multi-level STATCOM using line voltage total harmonic distortion minimization technique," IEEE Conference On Energy Conversion Congress and Exposition (ECCE),PP 1782-1787, 2012
- [5] ObradDordevic, Martin Jones, and Emil Levi,A ,"Comparison of Carrier-Based and Space Vector PWM Techniques for Three-Level Five-Phase Voltage Source Inverters", IEEE Transactions On Industrial Informatics, Vol. 9, No. 2,Pp 609-618, May 2013.
- [6] Raju.S ,Srivatchan.L,Chandrasekaran.V, Mohan. N,," Constant Pulse width modulation strategy for direct three level matrix converter", IEEE International Conference On Power Electronics, pp 1-5, Nov 2012.
- [7] EbrahimBabaei, SomayehAlilu, Sara Laali ,"A New General Topology for Cascaded Multilevel Inverters With Reduced Number of Components Based on Developed H-Bridge", IEEE Transactions On Industrial Electronics, Vol. 61, No. 8, Pp 3932-3939, August 2014
- [8] Sumit K. Chattopadhyay, and Chandan Chakraborty," A New Multilevel Inverter Topology With Self-Balancing Level Doubling Network", IEEE Transactions On Industrial Electronics, Vol. 61, No. 9, Pp 4622-4631, September 2014
- [9] Bahr Eldin S. Mohammed and K.S.RamaRao, "A New Multicarrier Based PWM For Multilevel Converter", IEEE applied power electronics colloquium (IAPEC),, 2011
- [10] Mariusz Malinowski, K.GopaKumar, Jose Rodriguez and Marcelo A.Perez, "A Survey on Cascaded Multilevel Inverters",IEEE Trans. On Ind.Electrons, Vol.57, no. 7, July 2010.
- [11] Batschauer, A.L., Mussa, S.A., and Heldwein, M.L., "Three Phase Hybrid Multilevel Inverter Based on Half Bridge Modules", IEEE Trans. on Industrial Electronics , vol.59, no.2, pp.668- 678, 2012.

International Journal of Innovative Research in Science, Engineering and Technology

(An ISO 3297: 2007 Certified Organization)

Vol. 4, Special Issue 6, May 2015

- [12] AlirezaNami, FiruzZare, Arindam Ghosh and FredeBlaabjerg, "A Hybrid Cascade Converter Topology With Series-Connected Symmetrical and Asymmetrical Diode-Clamped H-Bridge Cells", IEEE Transactions On Power Electronics, Vol. 26, No. 1, January 2011.
- [13] Jing Zhao, Yunlong Han, Xiangning He, Cheng Tan, Jun Cheng, and Rongxiang Zhao, "Multilevel Circuit Topologies Based on the Switched-Capacitor Converter and Diode-Clamped Converter", IEEE Transactions on Power Electronics, Vol. 26, No. 8, August 2011.
- [14] Jeffrey Ewanchuk, John Salmon, and BehzadVafakha, "A Five-/Nine-Level Twelve-Switch Neutral-Point-Clamped Inverter for High-Speed Electric Drives", IEEE Transactions On Industry Applications, Vol. 47, No. 5, September/October 2011.
- [15] Robert Stala, "Application of Balancing Circuit for DC-Link Voltages Balance in a Single-Phase Diode-Clamped Inverter With Two Three-Level Legs", IEEE Transactions On Industrial Electronics, Vol. 58, No. 9, September 2011.