

STATCOM Based of Adaptive Control Technique to Enhance Voltage Stability on Power Grid

N.Yuvaraj¹, B.Deepan², M.Muruganandam³, S.Saravanan³

PG Scholar, Dept of EEE, Muthayammal Engineering College, Rasipuram, Tamilnadu, India¹

Assistant Professor, Dept of EEE, Muthayammal Engineering College, Rasipuram, Tamilnadu, India²

Professor, Dept of EEE, Muthayammal Engineering College, Rasipuram, Tamilnadu, India³

ABSTRACT: In this STATCOM can to be ensure fast and efficient support for reactive power system voltage stability. In the literature, various methods to control STATCOM are discussed, including many applications the proportional-integral (PI) controller. However, these earlier works get the PI gains on a trial-and-error method or extensive studies with a compromise of performance and applicability. Therefore, the control parameters for optimum performance for a given operating point may not be effective in a different operating point. This article proposes a new control model based on adaptive PI control, which can adjust the control gains even in case of failure, so that the power always corresponds to a desired reaction, regardless of the change in operating condition. Since the setting is autonomous, that is the plug-and-play capability for STATCOM operation. In that simulation test, the adaptive PI control shows consistent excellence under various operating conditions, such as dissimilar initial control gains, different load levels, change the transmission network successive disturbances, and serious incident. In contrast, the conventional controller with STATCOM tuned, fixed PI gains usually lead well in the original system, but cannot efficiently perform, such as the proposed control method when there is a change of system conditions.

KEYWORDS: Adaptive control, plug and play, proportional-integrals (PI) control, reactive power compensation, STATCOM, voltage stability.

I INTRODUCTION

voltage stability is an important consideration in improving the safety and reliability of power supply systems. The static compensator (STATCOM), a popular device for reactive power control based on gate turn-off (GTO) thyristors, has gained much interest in this last decade to improve the network stability. In the past, various methods have been proposed to combat STATCOM control. References mainly focus on the control design, rather than to explore how (PI) is set proportional-integral control gains. In many STATCOM models the control logic is implemented using the PI controller. The control parameters or gains play a key factor STATCOM performance. At present, only few studies have been carried out in the control parameter settings. In the PI controller gains are designed in a case-by-case study or trial-and-error approach with compromises in performance and efficiency.

The STATCOM is normally designed to provide fast voltage control to enhance the stability of system. Two basic controls are implemented in a STATCOM. The first is the AC voltage regulation across the grid and second one is the control of the DC voltage across the capacitor. By using the above controller the active power injection from the STATCOM to the grid is being controlled.

Conventionally PI controllers have been use as regulates of STATCOM. Conventional PI controller has limitation over its operating range. It is highly inefficient during nonlinear operations.

These challenges gave to some selected devices to control or compensate reactive power. In order to cover the additional demand for reactive power and maintain the ability to control voltage stability within the target range, various sources of reactive power. In recent decades there has been significant progress in terms of equipment designed to improve the stability of voltage in power systems. This

International Journal of Innovative Research in Science, Engineering and Technology

(An ISO 3297: 2007 Certified Organization)

Vol. 4, Special Issue 6, May 2015

is mainly due to the development of power supply systems in the world, which requires seeking better ways of adjusting and controlling power flows and voltage levels. Reactive power is essential to move active power through the transmission and distribution system to the customer.

This, motivation is an adaptive PI control STATCOM for voltage regulation in this paper. With this adaptive PI control method, the PI control parameters can even be adjusted automatically and dynamically under various disturbances in a power system be. If a fault occurs in the system, the PI controller parameters can be calculated for STATCOM automatically in each sampling time periods and can be adjusted in real time to track the reference voltage.

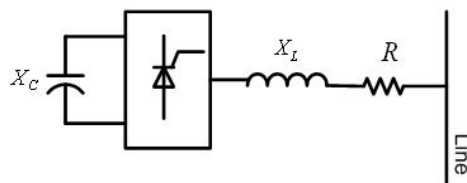

Fig.1.Basic structure of STATCOM.

The STATCOM (also known as the static VAR generator(SVG)) is a voltage converter device which uses in order to generate the active and reactive power needed by the system. The STATCOM has several advantages including fast response, continuous and quick control of reactive power, and smaller storage capacitance. In addition, the ability of the reactive power compensation in STATCOM is better than SVC.

Therefore, STATCOM may consider as an effective solution to the problem of voltage stability. Figure 6 shows the basic structure of STATCOM. It is a shunt connected device which is connected to the grid through a series reactance. Different from other control methods, it is will not be affected by the initial gain settings, and changes of system conditions, and the limits of hum an experience and judgment. This will make the STATCOM a “plug-and-play” device. In addition, this research work demonstrates fast, dynamic performance of the STATCOM in various operating conditions.

This paper is organized as follows. Section II illustrates the system configuration and STATCOM dynamic model. Section III presents the adaptive PI control method with an algorithm flow chart. Section IV compares the adaptive PI control methods with the traditional PI control, and presents the simulation results. Finally, sections V conclude this paper.

MODEL CONTROL OF STATCOM

System Configuration

The equivalent circuit Of the STATCOM is shown in Fig.1.In this power system, the resistance in series with the voltage-source inverter represent the sum of the transformer winding resistance losses and the inverter conduction losses. The inductance represents the leakage inductance of the transformer. The resistance in shunt with the capacitor represents the sum of the switching losses o f the inverter and the power losses in the capacitor. In Fig.1, V_{as} , V_{bs} , and V_{cs} are the three-phase STATCOM output voltages; V_{a1} , V_{b1} , and V_{c1} are the three- phase bus voltages; i_{as} , i_{bs} , and i_{cs} are the three-phase STATCOM output currents .

Dynamic Model of STATCOM

The three-phase mathematical expressions of the STATCOM can be written in the following form.

International Journal of Innovative Research in Science, Engineering and Technology

(An ISO 3297: 2007 Certified Organization)

Vol. 4, Special Issue 6, May 2015

$$L_s \frac{di_{as}}{dt} = -R_s i_{as} + V_{as} - V_{dl} \tag{1}$$

$$L_s \frac{di_{bs}}{dt} = -R_s i_{bs} + V_{bs} - V_{bl} \tag{2}$$

$$L_s \frac{di_{cs}}{dt} = -R_s i_{cs} + V_{cs} - V_{cl} \tag{3}$$

$$\frac{d}{dt} \left[\frac{1}{2} C V_{dc}^2(t) \right] = -[V_{as} i_{as} + V_{bs} i_{bs} + V_{cs} i_{cs}] - \frac{V_{dc}^2(t)}{R_c} \tag{4}$$

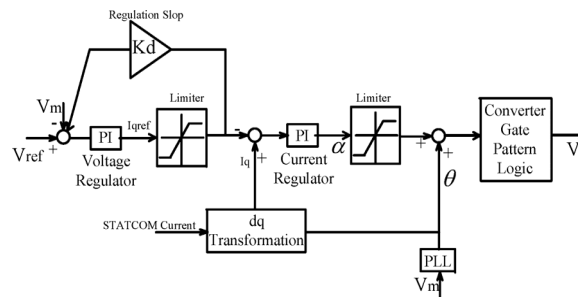

Fig.2.Traditional STATCOM PI control block diagram

By using the abc/dq transformation, the equations from (1) to (4) can be rewritten as

$$\frac{d}{dt} \begin{bmatrix} i_{ds} \\ i_{qs} \\ V_{dc} \end{bmatrix} = \begin{bmatrix} -\frac{R_s}{L_s} & \omega & \frac{K}{L_s} \cos \alpha \\ -\omega & -\frac{R_s}{L_s} & \frac{K}{L_s} \sin \alpha \\ -\frac{3K}{2C} \cos \alpha & \sin \alpha & -\frac{1}{R_c C} \end{bmatrix} \begin{bmatrix} i_{ds} \\ i_{qs} \\ V_{dc} \end{bmatrix} - \frac{1}{L_s} \begin{bmatrix} V_{dl} \\ V_{ql} \\ 0 \end{bmatrix} \tag{5}$$

Where i_{ds} and i_{qs} are the d and q currents corresponding to $i_{as}, i_{bs},$ and i_{cs} ; K is a factor that relates the dc voltage to the peak phase to neutral voltage on the ac side; V_{dc} is the dc side voltage; α is the phase angle at which the STATCOM output voltage leads the bus voltage; ω is the synchronously rotating angle speed of the voltage vector; and V_{dl} and V_{ql} represent the d and q axis voltage corresponding to $V_{al}, V_{bl},$ and V_{cl} . Since $v_{ql}=0$, based on the instantaneous active and reactive power definition, (6) and (7) can be obtained as

$$P_l = \frac{3}{2} V_{dl} i_{ds} \tag{6}$$

International Journal of Innovative Research in Science, Engineering and Technology

(An ISO 3297: 2007 Certified Organization)

Vol. 4, Special Issue 6, May 2015

$$q_i = \frac{3}{2} V_{dt} I_{qs}$$

(7)

Based on the above equations, the traditional control strategy can be obtained, and the STATCOM control block diagram is shown in fig.2.

As shown in fig 2. the phase locked loop provides the basic synchronising signal which is the reference angle to the measurement system. Measured bus line voltage V_m is compared with the reference signal V_{ref} , and the voltage regulator provides the required reactive reference current I_{qref} . The droop factor K_d is defined as the allowable voltage error at the rated reactive current I_q is compared with I_{qref} , and the output of the current regulator is the angle phase shift of the inverter voltage with regard to the system voltage. The limiter is the limit imposed on the value of control while considering the maximum reactive power capability of the STATCOM.

II. ADAPTIVE PI CONTROL FOR STATCOM

Concept of the Proposed Adaptive PI Control Method

The STATCOM with fixed PI control parameters may not reach the desired and acceptable response in the power system when the power system operating condition (e.g., loads or transmissions) changes. An adaptive PI control method is presented in this section in order to obtain the desired response and to avoid performing trial and error studies to find suitable parameters can be realized.

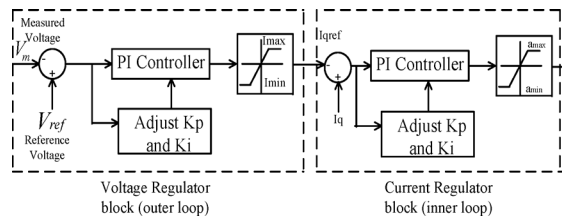

Fig.3. Adaptive PI control block for STATCOM.

An adaptive PI control block for STATCOM is shown in Fig.3. In Fig.3, the measured voltage $V_m(t)$ and the reference voltage $V_{ref}(t)$, and the $-$ axis reference current and the q -axis current are in per unit values. The proportional and integral parts of the voltage regulator gains are denoted by K_{p-v} and K_{i-v} , respectively. Similarly, the gains K_{p-i} and K_{i-i} represent the proportional and integral parts, respectively, of the current regulator. In this control system, the allowable voltage error K_d is set to 0. The K_{p-v} , K_{i-v} , K_{p-i} , and K_{i-i} can be set to an arbitrary initial value such as simply 1.0.

The process of the adaptive voltage-control method for STATCOM is described as follows,

- 1) The bus voltage $V_m(t)$ is measured in real time.
- 2) When the measured bus voltage over time $V_m(t) \neq V_{ss}$, the target steady-state voltage, which is set to 1.0 per unit (p.u.) in the discussion and examples, $V_m(t)$ is compared with V_{ss} . Based on the desired reference voltage curve, K_{p-v} and K_{i-v} are dynamically adjusted in order to make the measured voltage match the desired reference voltage, and the q -axis reference current I_{qref} can be obtained.
- 3) In the inner loop, I_{qref} is compared with the $-$ axis current I_q . Using the similar control method like the one for the outer loop, the parameters K_{p-i} and K_{i-i} can be adjusted based on the error. Then, a suitable angle can be found eventually the dc voltage in STATCOM can be modified such that STATCOM provides the exact amount of reactive power injected into the system to keep the bus voltage at the desired value.

It should be noted that the current I_{max} and I_{min} and the angle α_{max} and α_{min} are the limits imposed with the consideration of the maximum reactive power generation capability of the STATCOM controlled in this manner. If one of the maximum or minimum limits is reached, the maximum capability of the STATCOM to inject reactive power has

International Journal of Innovative Research in Science, Engineering and Technology

(An ISO 3297: 2007 Certified Organization)

Vol. 4, Special Issue 6, May 2015

been reached Certainly, as long as the STATCOM sizing has been appropriately studied during planning stages for inserting the STATCOM into the power system, the STATCOM should not reach its limit un- expectedly.

Key Equations

Since the inner loop control is similar to the outer loop control, the mathematical method to automatically adjust PI controller gains in the outer loop is discussed in this section for illustrative purposes. A similar analysis can be applied to the inner loop.

Here, $V_d(t)$ and $V_{qi}(t)$ can be computed with the d-q transformation

$$\begin{bmatrix} V_{di}(t) \\ V_{qi}(t) \\ 0 \end{bmatrix} = \frac{2}{3} \begin{bmatrix} 1 & -\frac{1}{2} & -\frac{1}{2} \\ 0 & \frac{\sqrt{3}}{2} & -\frac{\sqrt{3}}{2} \\ \frac{1}{\sqrt{2}} & \frac{1}{\sqrt{2}} & \frac{1}{\sqrt{2}} \end{bmatrix} \begin{bmatrix} V_{ai}(t) \\ V_{bi}(t) \\ V_{ci}(t) \end{bmatrix} \quad (8)$$

Then, we have

$$V_m(t) = \sqrt{V_{di}^2(t) + V_{qi}^2(t)} \quad (9)$$

Based on $V_m(t)$, the reference voltage $V_{ref}(t)$ is set as

$$V_{ref}(t) = V_{ss} - (V_{ss} - V_m(t))e^{-\frac{t}{\tau}} \quad (10)$$

In (10), V_{ss} is the target steady-state voltage, which is set to 1.0 p.u. in the discussion and example; $V_m(t)$ is the measured voltage; $\tau=0.01s$.

If the system is operating in the normal condition, then $V_m(t)= 1p.u.$ and thus, $V_{ref}(t)= 1p.u.$ This means that K_{p-v} and K_{i-v} will not change and the STATCOM will not inject or absorb any reactive power to maintain the voltage meeting the reference voltage. However, once there is a voltage disturbance in the power system, based on $V_{ref}(t) = V_{ss} - (V_{ss} - V_m(t))e^{-t/\tau}$. K_{p-v} and K_{i-v} will become adjustable and the STATCOM will provide reactive power to increase the voltage. Here, the error between $V_{ref}(t)$ and $V_m(t)$ is denoted by $\Delta V(t)$ when there is a disturbance in the power system. Based on the adaptive voltage-control model, at any arbitrary time instant t , the following equation can be obtained:

$$\Delta V(t)K_{p-v}(t) + K_{i-v}(t) \int_t^{t+T_s} \Delta V(t) dt = I_{qref}(t + T_s) \quad (11)$$

Where T_s is the sample time, which is set to 2.5×10^{-5} s here as an example.

III. SIMULATION RESULTS

System data

In the system simulation diagram shown in Fig. 4, a ± 100 -MVAR STATCOM is implemented with a 48-pulse VSC and connected to a 500-kV bus. This is the standard sample STATCOM system in Mat lab/simulink library, and all machines used in the simulation are dynamically models [10]-[120]. Here, the attention is focused on the STATCOM control performance in bus voltage regulation mode. In the original model, the compensating reactive power injection and the regulation speed are mainly affected by PI controller parameters in the voltage regulator and the current regulator.

The original control will be compared with the proposed adaptive PI control model.

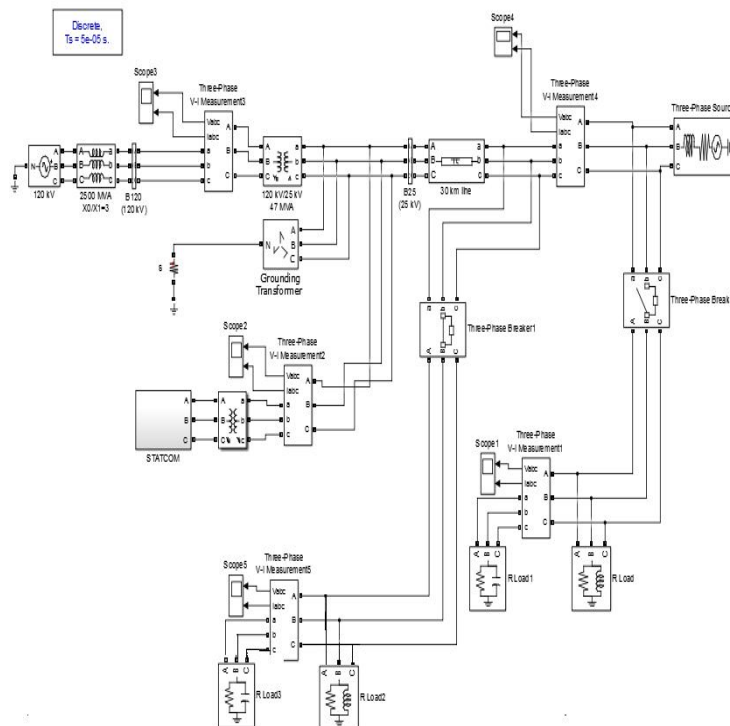

Fig. 5. Simulink model of adaptive control technique for statcom to enhance voltage stability on power grid

Assume the steady-state voltage, $V_{ss} = 1.0$ p.u. In sections IV-B, C, and F, a disturbance is assumed to cause a voltage drop at 0.2 s from 1.0 to 0.989 p.u. at the source (substation A). Here, the 0.989-p.u. voltage at substation A is the lowest voltage that the STATCOM system can support due to its capacity limit. The third simulation study in subsection IV-D assumes a voltage rise from 1.0 to 1.01 p.u.

Under a change load. The fourth simulation study in Subsection IV-E assumes a disturbance at 0.2 s, causing a voltage rise from 1.0 to 1.01 p.u. at substation A under a modified transmission network. In Subsection IV-F, a disturbance at 0.2 s causes a voltage decrease from 1.0 to 0.989 p.u. occurring at substation A. After that line 1 is switched off at 0.25

International Journal of Innovative Research in Science, Engineering and Technology

(An ISO 3297: 2007 Certified Organization)

Vol. 4, Special Issue 6, May 2015

s. In Subsection IV-G, a severe disturbance is assumed with a voltage sag of 60% of the rated voltage. When the fault clears, the voltage gets back to around 1.0 p.u.

In all simulation studies, the STATCOM immediately operates after the disturbance with the expectation of bringing the voltage back to 1.0. The proposed control and the original PI control are studied and compared.

Response of the output results

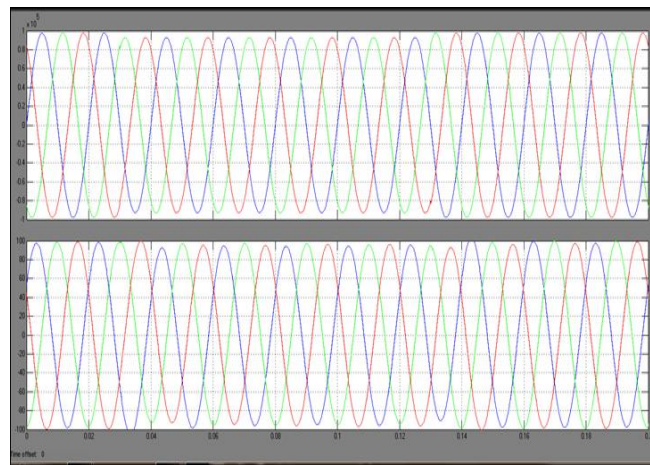

Fig 6. Input Waveform for Source

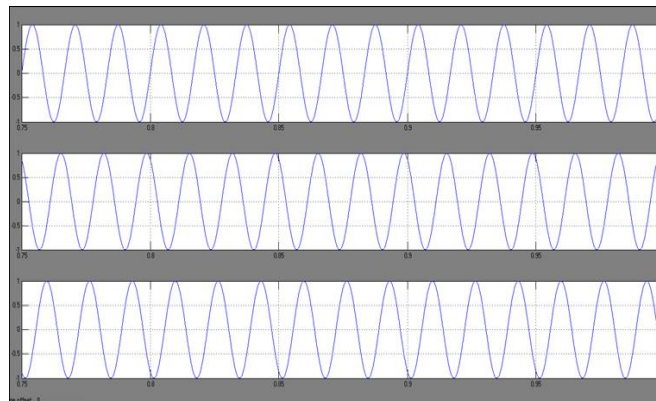

Fig 7. voltage of output reactive power system

IV. CONCLUSION AND FUTURE WORK

In the literature, various methods to control STATCOM are discussed, including many applications of the PI controller. However, these earlier works get the PI gains over a trial-and-error approach or extensive studies with a compromise of performance and applicability. Therefore, control parameters for optimum performance for a given operating point can not always be effective in a different operating point. To meet the challenge, this paper proposes a new control model based on adaptive PI

which can adjust itself the control gains dynamically during disturbances, so that the power will always fit a desired reaction, regardless of the change in operating condition. Since the setting is autonomous, that is the "plug-and-play" capability for STATCOM operation.

International Journal of Innovative Research in Science, Engineering and Technology

(An ISO 3297: 2007 Certified Organization)

Vol. 4, Special Issue 6, May 2015

In the simulation study, the proposed adaptive PI control for STATCOM is compared with the conventional controller with STATCOM pretuned fixed PI gains to verify the advantages of the proposed method. The results show that the adaptive PI controller provides consistently good performance under various operating conditions, such as different initial control gains, different load levels, modification of the transmission network, successive disturbances, and serious incident. In contrast, the conventional control STATCOM with fixed gains PI has an acceptable performance in the original system, but can not efficiently perform, such as the proposed control method when there is a change of system conditions. Future work may in the investigation of several STATCOMs since the interaction between different STATCOMs, each other. Also, the extension to other network control problems can be explored are influenced.

In the simulation study, the proposed adaptive PI control for STATCOM with the conventional STATCOM control compared with pre-tuned fixed gains PI to verify the advantages of the proposed method.

REFERENCES

- [1] A. Jain, K. Joshi, A. Behal, and N. Mohan, "Voltage regulation with STATCOMs: Modeling, control and results," *IEEE Trans. Power Del.*, vol. 21, no. 2, pp. 726–735, Apr. 2006.
- [2] D. Soto and R. Pena, "Nonlinear control strategies for cascaded multilevel STATCOMs," *IEEE Trans. Power Del.*, vol. 19, no. 4, pp.1919–1927, Oct. 2004.
- [3] C. Hochgraf and R. H. Lasseter, "STATCOM controls for operation with unbalanced voltage," *IEEE Trans. Power Del.*, vol. 13, no. 2, pp.538–544, Apr. 1998.
- [4] G. E. Valdarannma, P. Mattavalli, and A. M. Stankonic, "Reactive power and unbalance compensation using STATCOM with dissipation based control," *IEEE Trans. Control Syst. Technol.*, vol. 19, no.5, pp. 598–608, Sep. 2001.
- [5] A. H. Norouzi and A. M. Sharaf, "Two control schemes to enhance the dynamic performance of the STATCOM and SSSC," *IEEE Trans. Power Del.*, vol. 20, no. 1, pp. 435–442, Jan. 2005.
- [6] M. S. E. Moursi and A. M. Sharaf, "Novel controllers for the 48-pulse VSC STATCOM and SSSC for voltage regulation and reactive power compensation," *IEEE Trans. Power Syst.*, vol. 20, no. 4, pp.1985–1997, Nov.2005
- [7] H. Li, F. Li, J. D. Kueck, and D. T. Rzy, "Adaptive voltage control with distributed energy resources: Algorithm, theoretical analysis, simulation and field test verification," *IEEE Trans. Power Syst.*, vol. 25, no.3, pp. 1638–1647, Aug. 2010.
- [8] H. Li, F. Li, Y. Xu, D. T. Rzy, and S. Adhikari, "Autonomous and adaptive voltage control using multiple distributed energy resources," *IEEE Trans. Power Syst.*, vol. 28, no. 2, pp. 718–730, May 2013.
- [9] P. Rao, M. L. Crow, and Z. Yang, "STATCOM control for power system voltage control applications," *IEEE Trans. Power Del.*, vol.15, no. 4, pp. 1311–1317, Oct. 2000.
- [10] K. Wang and M. L. Crow, "Power system voltage regulation via STATCOM internal nonlinear control," *IEEE Trans. Power Syst.*, vol.26, no. 3, pp. 1252–1262, Aug. 2011.
- [11] J Vinoth, T Muthukumar, M Muruganandam, "Implementation of Distributed Maximum Power Point Tracking for Partially Shaded PV Systems", *International Journal of Advanced Research in Electrical, Electronics and Instrumentation Engineering*,vol.4,issue,2,pp. 702-709,feb.2015
- [12] P Ranjitha, V Dhinesh, M Muruganandam, "Soft Switching with Cascaded Transformers to Drive the PMDC Motor", *International Journal of Advanced Research in Electrical, Electronics and Instrumentation Engineering*,vol.4,issue,2,pp. 787-794,feb.2015
- [13] G Maruthaipandian, S Ramkumar, M Muruganandam, "Design and Implementation of BLDC Motor Using Regenerative Braking for Electric Vehicle", *International Journal of Advanced Research in Electrical, Electronics and Instrumentation Engineering*,vol.4,issue,2,pp. 694-701,feb.2015
- [14] S LakshmiPriya, RK Raghav, M Muruganandam, "A Thirteen Level Inverter Design Based on Hybrid MLI Topology for Minimum THD", *International Journal of Advanced Research in Electrical, Electronics and Instrumentation Engineering*,vol.4,issue,2,pp. 976-983,feb.2015
- [15] R Pavithra, M Muruganandam, "A Sensorless Current Controlled DC-DC Converter with Intelligent Control Technique", *International Journal of Advanced Research in Electrical, Electronics and Instrumentation Engineering*,vol.4,issue,2,pp 779-786. .feb.2015
- [16] M Saravanakumar, C Harris Naveena, M Muruganandam, "Bidirectional Modular Multilevel DC/DC Converter with Wide Range of Control", *International Journal of Advanced Research in Electrical, Electronics and Instrumentation Engineering*,vol.4,issue,2,pp. 984-989 ,feb.2015