

Improvement of Transient Stability in Power Systems using Matrix Converter Based UPFC with ANN

V.Bharathi¹, P.Lakshmanan²

PG Student [PSE], Department of EEE, V.S.B Engineering College, Karur, Tamilnadu, India¹

Assistant Professor, Department of EEE, V.S.B Engineering College, Karur, Tamilnadu, India²

ABSTRACT: In modern era, the electrical power demand is high and it is still growing therefore it is necessary to utilize the transmission lines up to its maximum loadable limit. The transient stability limits the maximum loading of the power system and it causes the system to become unstable below its steady state stability limit. In this paper, the improvement of transient stability of a taken study system using matrix converter based UPFC is analyzed. Here the matrix converter is controlled using space vector modulation technique. The study system is simulated using MATLAB - Simulink under three phase fault condition with and without matrix converter and the result obtained at both the case are compared.

KEYWORDS: Transient Stability, UPFC, MATLAB Matrix Converter.

I. INTRODUCTION

The construction of new generating stations and transmission systems are delayed due to the right of way, economic and other problems. Therefore it is necessary to modify the traditional methods used to control the power systems and this will lead to improved reliability, flexibility and control. One of the most important inventions in transmission side is FACTS devices which allow us to utilize the transmission lines near its maximum operating limits. Out of all FACTS devices a valuable device is Unified Power Flow Controller. The main drawback of the conventional UPFC is the size of the DC link capacitor which makes it bulky and its performance will deteriorate due to ageing. This problem can be overcome by the use of matrix converter based UPFC. This configuration of UPFC is used to improve the transient stability of the study system under three phase fault. It is done by controlling the power flow in the transmission line.

II. CONVENTIONAL UPFC

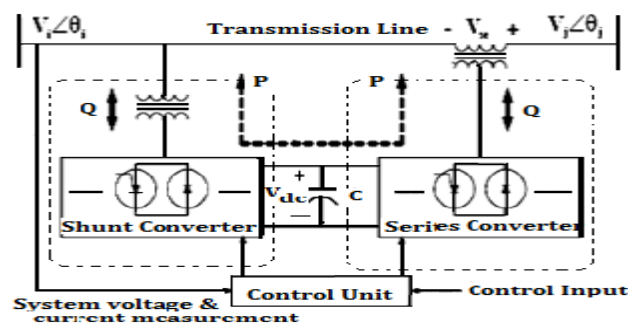

Fig.1. Schematic diagram of UPFC

It is a combination of SSSC and STATCOM. It consists of series and shunt connected voltage source inverters connected via a DC link. The shunt connected converter is used for maintaining the DC link voltage where as the series connected inverter is used for injecting the real and reactive power into the line. The cost, size, performance reduction due to ageing is the major disadvantages of the DC link capacitor employed.

International Journal of Innovative Research in Science, Engineering and Technology

(An ISO 3297: 2007 Certified Organization)

Vol. 4, Special Issue 6, May 2015

III. MATRIX CONVERTER BASED UPFC

It contains nine bidirectional switches which replace the shunt, series converters and the DC link capacitor in the conventional UPFC. There are 512 switching combinations available and out of that only 27 switching combinations are permitted. The permitted combinations is based on the following rules, the input phases will not be short circuited and the output will not be open circuited at any instant of operation. Only three switches are conducting at a time and the switching losses are also minimized in comparison with conventional UPFC. Each output waveform is obtained by sequential sampling of input waveform.

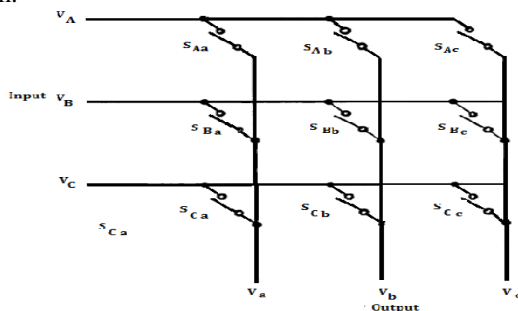

Fig.2. Schematic diagram of Matrix converter

Due to the absence of energy storage elements in matrix converter, the output voltage is obtained from input voltages. The required output waveform is got by sampling the input waveform sequentially. Since no energy storage components are present between the input and output sides of the matrix converter, the output voltages have to be generated directly from the input voltages. Each output voltage waveform is synthesized by sequential piecewise sampling of the input voltage waveforms.

Table 1 Matrix Converter Switching Vector

Group State	Phase			Output voltage			Input current			Switching function values								
	A	B	C	u_{AB}	u_{BC}	u_{CA}	i_a	i_b	i_c	SW_{Aa}	SW_{Ab}	SW_{Ac}	SW_{Ba}	SW_{Bb}	SW_{Bc}	SW_{Ca}	SW_{Cb}	SW_{Cc}
I	i	a	b	u_{ab}	u_{bc}	u_{ca}	i_A	i_B	i_C	1	0	0	0	1	0	0	0	1
	ii	a	c	$-u_{ca}$	$-u_{bc}$	$-u_{ab}$	i_A	i_C	i_B	1	0	0	0	0	1	0	1	0
	iii	b	a	$-u_{ab}$	$-u_{ca}$	$-u_{bc}$	i_B	i_A	i_C	0	1	0	1	0	0	0	0	1
	iv	b	c	u_{bc}	u_{ca}	u_{ab}	i_C	i_A	i_B	0	1	0	0	0	1	1	0	0
	v	c	a	u_{ca}	u_{ab}	u_{bc}	i_B	i_C	i_A	0	0	1	1	0	0	0	1	0
	vi	c	b	$-u_{bc}$	$-u_{ab}$	$-u_{ca}$	i_C	i_B	i_A	0	0	1	0	1	0	1	0	0
IIA	i	a	c	$-u_{ca}$	0	u_{ca}	i_A	0	$-i_A$	1	0	0	0	0	1	0	0	1
	ii	b	c	u_{bc}	0	$-u_{bc}$	0	i_A	$-i_A$	0	1	0	0	0	1	0	0	1
	iii	b	a	$-u_{ab}$	0	u_{ab}	$-i_A$	i_A	0	0	1	0	1	0	0	1	0	0
	iv	c	a	u_{ca}	0	$-u_{ca}$	$-i_A$	0	i_A	0	0	1	1	0	0	1	0	0
	v	c	b	$-u_{bc}$	0	u_{bc}	0	$-i_A$	i_A	0	0	1	0	1	0	0	1	0
	vi	a	b	u_{ab}	0	$-u_{ab}$	i_A	$-i_A$	0	1	0	0	0	1	0	0	1	0
IIB	i	c	a	u_{ca}	$-u_{ca}$	0	i_B	0	$-i_B$	0	0	1	1	0	0	0	0	1
	ii	c	b	$-u_{bc}$	u_{bc}	0	0	i_B	$-i_B$	0	0	1	0	1	0	0	0	1
	iii	a	b	u_{ab}	$-u_{ab}$	0	$-i_B$	i_B	0	1	0	0	0	1	0	1	0	0
	iv	a	c	$-u_{ca}$	u_{ca}	0	$-i_B$	0	i_B	1	0	0	0	0	1	1	0	0
	v	b	c	u_{bc}	$-u_{bc}$	0	0	$-i_B$	i_B	0	1	0	0	0	1	0	1	0
	vi	b	a	$-u_{ab}$	u_{ab}	0	i_B	$-i_B$	0	0	1	0	1	0	0	0	1	0
IIC	i	c	c	0	u_{ca}	$-u_{ca}$	i_C	0	$-i_C$	0	0	1	0	0	1	1	0	0
	ii	c	c	0	$-u_{bc}$	u_{bc}	0	i_C	$-i_C$	0	0	1	0	0	1	0	1	0
	iii	a	a	0	u_{ab}	$-u_{ab}$	$-i_C$	i_C	0	1	0	0	1	0	0	0	1	0
	iv	a	a	0	$-u_{ca}$	u_{ca}	$-i_C$	0	i_C	1	0	0	1	0	0	0	0	1
	v	b	b	0	u_{bc}	$-u_{bc}$	0	$-i_C$	i_C	0	1	0	0	1	0	0	0	1
	vi	b	b	0	$-u_{ab}$	u_{ab}	i_C	$-i_C$	0	0	1	0	0	1	0	1	0	0
III	i	a	a	0	0	0	0	0	0	1	0	0	1	0	0	1	0	0
	ii	b	b	0	0	0	0	0	0	0	1	0	0	1	0	0	1	0
	iii	c	c	0	0	0	0	0	0	0	0	1	0	0	1	0	0	1

International Journal of Innovative Research in Science, Engineering and Technology

(An ISO 3297: 2007 Certified Organization)

Vol. 4, Special Issue 6, May 2015

The input voltage equations for Matrix converter is given below.

$$V_a = V_m \cos \theta_{av} = V_m \cos(\omega t) \quad (1)$$

$$V_b = V_m \cos \theta_{bv} = V_m \cos(\omega t - (\frac{2\pi}{3})) \quad (2)$$

$$V_c = V_m \cos \theta_{cv} = V_m \cos(\omega t + (\frac{2\pi}{3})) \quad (3)$$

The line side current in the shunt converter is given as,

$$I_a = I_m \cos \theta_{av} = I_m \cos(\omega t - \psi_{in}) \quad (4)$$

$$I_b = I_m \cos \theta_{bv} = I_m \cos(\omega t - (\frac{2\pi}{3}) - \psi_{in}) \quad (5)$$

$$I_c = I_m \cos \theta_{cv} = I_m \cos(\omega t + (\frac{2\pi}{3}) - \psi_{in}) \quad (6)$$

The output voltage injected to the line is given as,

$$V_u = V_o \cos \theta_{ou} = V_o \cos(\omega t + \varphi_o + \psi_{out}) \quad (8)$$

$$V_v = V_o \cos \theta_{ov} = V_o \cos(\theta_{ou} - (\frac{2\pi}{3})) \quad (9)$$

$$V_w = V_o \cos \theta_{ow} = V_o \cos(\theta_{ou} + (\frac{2\pi}{3})) \quad (10)$$

IV. MODULATION TECHNIQUE

The high voltage gain and reduced distortion of SVM over PWM technique increased its application. This technique is applied simultaneously to input current and output voltage vectors. The matrix converter has entire control of output voltage and displacement angle of input current in the presence of disturbances. The output voltage is given by

$$V_o = \frac{2}{3} [v_{ab} + v_{bc} \exp(-j120^\circ) + v_{ca} \exp(j120^\circ)] \quad (10)$$

The switching topologies in Group II and Group III are only used in SVM. Group II has stationary or active vectors which are having constant angular positions. Group III has zero vectors and it is used with stationary vectors of group II to obtain output voltage. During every sampling period T_s , the algorithm chooses four stationary vectors and zero vectors to construct the reference voltage for required output voltage and input current. The reference voltage amplitude and phase angle are computed and then required phase angle of input current is calculated. Using SVM the equations required for calculating on time of vectors are given below. The equations used for calculating on time of the four stationary vectors in SVM are

$$t_1 = \frac{2qT_s}{\sqrt{3} \cos \varphi_i} \sin(60^\circ - \theta_o) \sin(60^\circ - \theta_i) \quad (11)$$

$$t_2 = \frac{2qT_s}{\sqrt{3} \cos \varphi_i} \sin(60^\circ - \theta_o) \sin(\theta_i) \quad (12)$$

$$t_3 = \frac{2qT_s}{\sqrt{3} \cos \varphi_i} \sin(\theta_o) \sin(60^\circ - \theta_i) \quad (13)$$

$$t_4 = \frac{2qT_s}{\sqrt{3} \cos \varphi_i} \sin(\theta_o) \sin(\theta_i) \quad (14)$$

The equation for calculating the two zero vector time is given as

$$t_o = T_s - \sum_{i=1}^4 t_i \quad (15)$$

V. CONTROL TECHNIQUE

During the three phase fault condition the generator decelerates, in that instant the real power output of the generator gets reduced and the reactive power output increases. Here the UPFC supplies real power and absorbs reactive power in the line so as to keep the load angle within limit otherwise the load angle is increased above its maximum allowable value of 90 degree and the synchronous generator loses its synchronism.

VI.SIMULATION RESULTS

A. Simulation Diagram

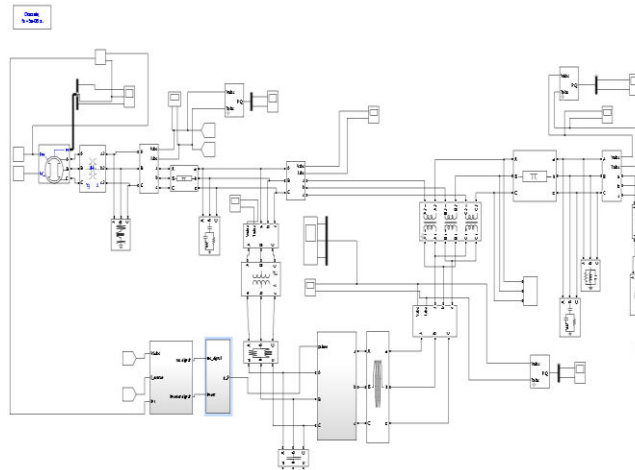

Fig.3 Simulation diagram with matrix converter based UPFC

Here the accelerating power of the generator is used to make the study system stable under fault. Here the indirect control of matrix converter is employed. The matrix converter is considered as a virtual AC-DC-AC converter and the switching pulses are generated for the rectifier and inverter as in conventional UPFC and then the switching pulses are converted to gate pulses required for matrix converter.

B.Waveforms

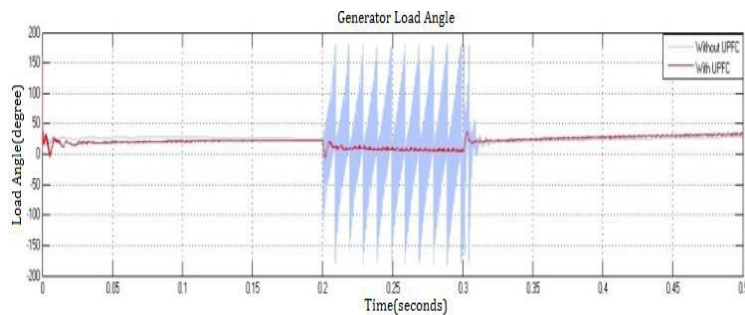

Fig.4. Generator load angle

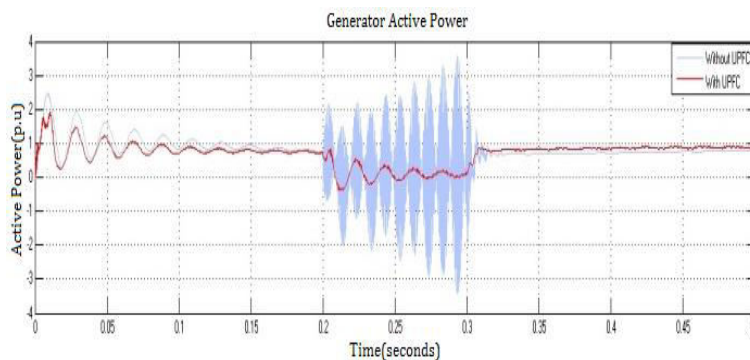

Fig.5. Generator active power output

International Journal of Innovative Research in Science, Engineering and Technology

(An ISO 3297: 2007 Certified Organization)

Vol. 4, Special Issue 6, May 2015

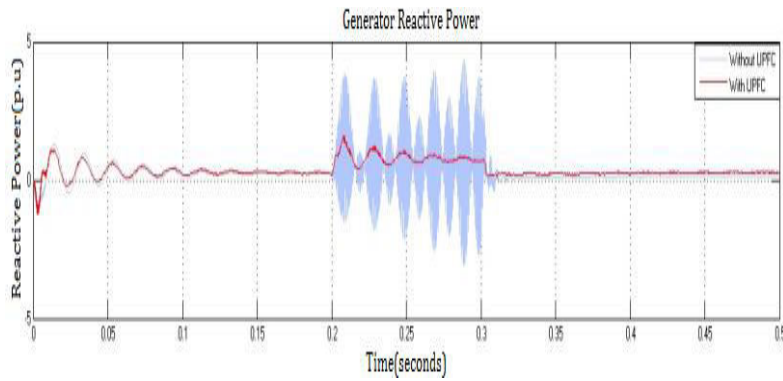

Fig.6. Generator reactive power output

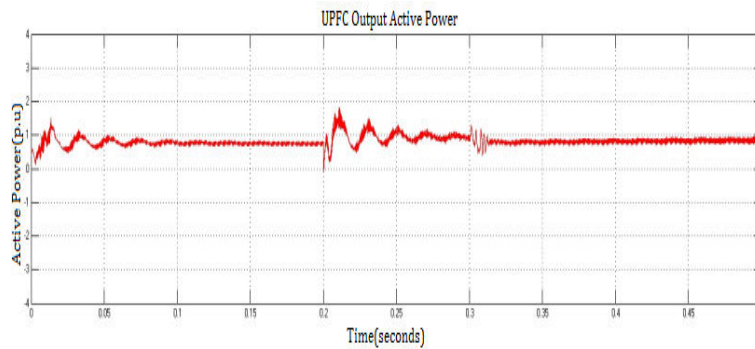

Fig.7. UPFC reactive power output

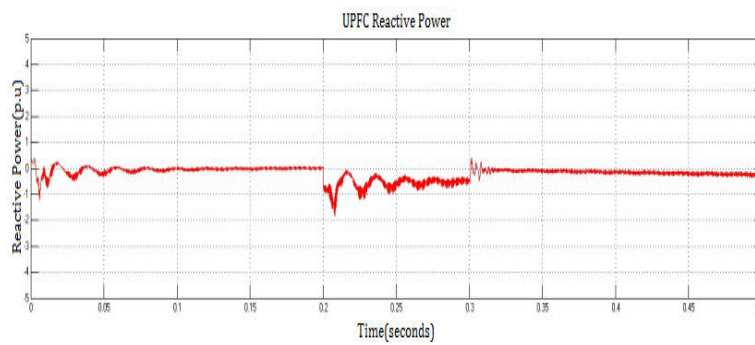

Fig.8. UPFC active power output

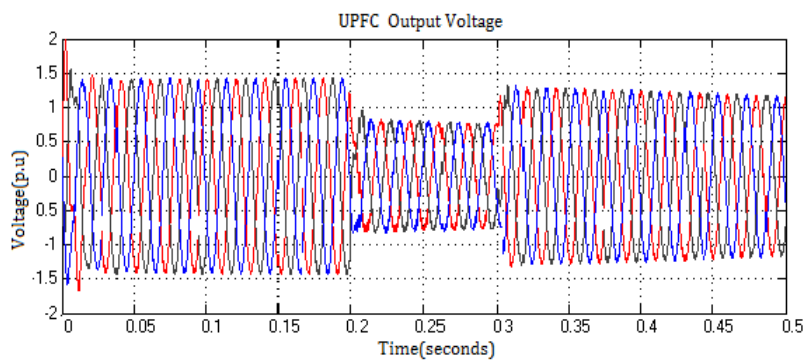

Fig.9. UPFC Output Voltage

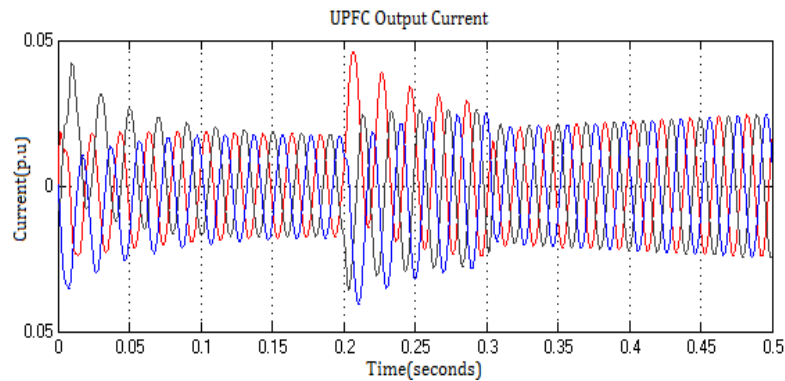

Fig.10. UPFC Output Current

C. Simulation data

The simulation is done in MATLAB with the following parameters.

Generator	:187 MVA, 13.8 kV, H=3.7s
Generator Transformer	:200MVA, 13.8kV/230kV
Transmission lines	:230 kV line, pi model of 50km and 180 km
Load	:300MW, 100MVAR
UPFC Shunt transformer	:150MVA, 230kV/27kV
UPFC Series transformer	:100MVA, 42kV/21 kV

VII.CONCLUSION

Transient stability of the test system is analyzed which consists of generator rated 187MVA/13.8kV connected to a generator transformer rated 200MVA, 13.8kV/230kV and connected to a load of 300MW, 1000MVAR through transmission line. A three phase fault is introduced in the test system at load side between 0.2 to 0.3 seconds.

Case (a) without UPFC

The generator load angle exceeds the maximum value of 90 degree within a cycle and the generator loses its synchronism as shown in the Fig.4.The active power output of the generator oscillates between -3.5p.u and 3.5p.u whereas the reactive power output of the generator oscillates between -3p.u and 4.25p.u as shown in the Fig.5 and Fig.6.

Case (b) with UPFC

Here the generator load angle is maintained at 5 degrees as shown in the Fig.4.The active power output of the generator decreases to -0.4p.u initially during fault and it gradually increases with the support of the UPFC supplying active power of 1.8p.u at initial fault condition and the active power output of the UPFC which is gradually reduces which is shown in the Fig.5 and Fig.8 respectively.

The reactive power output of the generator increases up to 1.6p.u peak at the same time UPFC supports the system by absorbing reactive power up to -1.8p.u peak which is shown in the Fig.6 and Fig.7 respectively.

International Journal of Innovative Research in Science, Engineering and Technology

(An ISO 3297: 2007 Certified Organization)

Vol. 4, Special Issue 6, May 2015

Table 2
Comparison with and without UPFC

Parameters	Fault condition without UPFC	Fault condition with UPFC
Load angle (degree) Normal condition 20 degree	-180 ⁰ to 180 ⁰	10 ⁰ to 5 ⁰
Generator active power output (p.u) Normal condition 0.7p.u	-3.5p.u to 3.5p.u	-0.4p.u peak
Generator reactive power output (p.u) Normal condition 0.23 p.u	-3p.u to 4.25p.u	1.6p.u peak
UPFC active power output (p.u)	-	1.8p.u peak and settles at 1p.u
UPFC reactive power output (p.u)	-	-1.8p.u and settles at -0.5p.u

The average operating time of a circuit breaker is 3 cycles and the fault clearing time is nearly 4 or 5 cycles which include both the relay operating time and the circuit breaker operating time and so the system without UPFC is definitely out of synchronism. It is clearly shown in the table 2 that the UPFC absorbs reactive power and supplies real power to support the system under fault condition and thus the transient stability of the system is ensured.

REFERENCES

- [1] Saidi Amara and HadjAbdallahHsan, "Power system stability improvement by FACTS devices: a comparison between STATCOM,SSSC and UPFC",IEEE First International Conference on Renewable Energy and Vehicular Technology,2012.
- [2] .Amir MasoudBozorgi, Mohamed Monfared and HabibRajabiMashhadi, "Optimum switching pattern of Matrix converter Space Vector Modulation",IEEE Second international eConference on Computer Knowledge Engineering(ICCKE),october 2012.
- [3] Padiyar, K.R., "Power System Dynamics Stability and Control", BS Publications, Hyderabad, 2nd edition, 2008
- [4] Bergen, A.R., Vittal, V., "Power Systems Analysis", Prentice-Hall, Inc, New Jersey, 2 edition, 2000
- [5] Huang, Z., Ni, Y., Shen, C.M., Wu, F.F., Chen, S., Zhang, B., "Application of Unified Power Flow Controller in Interconnected Power Systems -- Modeling,Interface, Control Strategy and Case Study", IEEE Power Engineering Society Summer Meeting, 1999.
- [6] Uzunovic, E., Canizares, C.A., Reeve, J., "EMTP Studies of UPFC Power Oscillation Damping", Proceedings of the North American Power Symposium (NAPS), San Luis Obispo, CA, October 1999, pp. 405-410
- [7] B.Mwinyiwiwa, Z.wolanski, B.T.Ooi, "High Power Switch Mode Linear Amplifiers for Flexible AC Transmission System", IEEE Transactions on Power Delivery, Vol. 11, No.4, October 1996, pp. 1993-1998.
- [8] Makombe, T., "An investigation of a unified power flow controller", PhD thesis, UMIST, UK, 1997
- [9] A-Edris, "Operation of the Unified Power Flow Controller (UPFC) under Practical Constraints", IEEE PES paper No. PE-511-PWRD-041-1996.
- [10] Round, S.D., Yu, Q., Norum, L.E., and Undeland, T.M., "Performance of a unified power flow controller using a d-q-control system", IEE conference on AC and DC transmission, London, Volume- 29,(April - May 1996).
- [11] Lombard, X., and Therond, P.G., "Control of unified power flow controller: comparison of methods on the basis of a detailed numerical model", IEEUPES Summer Meeting, (July -August 1996)
- [12] J-B-Ekanayake, N.Jenkins, "A Three-Level Advanced Static VAR Compensator ", IEEE Transactions on Power Delivery, Vol. 11, No. 1, January 1996, pp.540-545.
- [13] Mihalic, R, Zunko, P., Povh, D., "Modeling of Unified Power Flow Contreoller and its impact on power oscillation damping", Cigre Symposium, Power Electronics in Power Systems, Tokyo, May 1995.
- [14] Gyugyi, L., "The unified power flow controller: a new approach to power transmission control", IEEE Trans., Power Deliv.,Volume-10, (1995)
- [15] Kundur, P., Power System Stability and Control, McGraw-Hill, Inc., New York, 1994