

# **Analysis and Design of Series Inverter Based Load Reactive Power Compensation**

<sup>1</sup>Dr.C.Nagarajan, <sup>2</sup>R.Srinivasan, <sup>3</sup>V.R.Anand,

<sup>1</sup>Professor, Department of EEE, Muthayammal College of Engineering, Rasipuram, Tamilnadu, India

<sup>2</sup>Assistant Professor, Department of EEE, Muthayammal College of Engineering, Rasipuram, Tamilnadu, India

<sup>3</sup>PG Scholar, Department of EEE, Muthayammal College of Engineering, Rasipuram, Tamilnadu, India

**ABSTRACT:** The main objective of this project is to ensure the power quality. Power quality has become an important issue for several reasons e.g. modern society's growing dependence on electricity and the fact that the poor power quality may generate significant economic losses in few moments. Probable power quality problems are harmonic, flicker, voltage dips and supply interruptions. The power quality may be improved by using filters and compensators. This thesis introduces a new concept of optimal utilization of a unified power quality conditioner (UPQC). Through this project we are Experimentally Simulating and explaining the optimal utilization of a unified power quality conditioner (UPQC). The UPQC Converter is controlled to perform simultaneous operation of voltage sag compensation and load reactive power sharing when additional loads are added. The active power control approach is used to compensate voltage sag and is integrated with theory of power angle control (PAC) of UPQC to coordinate the load reactive power between the two inverters.

Unified power quality conditioners (UPQCs) allow the mitigation of voltage and current disturbances that could affect sensitive electrical loads while compensating the load reactive power. This paper deals with unified power quality conditioner (UPQC), which aims at the Voltage Sag compensation by using Solar Power to compensate during Additional Loads requirements. The main purpose of a UPQC is to compensate for voltage imbalance, reactive power, negative-sequence current and harmonics. In this paper, unified power quality conditioner (UPQC) is designed and simulated by Artificial Neural Network theory. The proposed system is comprised of series and shunt inverters which can compensate the sag, swell and unbalance voltage, harmonics and also the reactive power. PI controller is used to stabilize DC link voltage and balance the active power between the shunt and series inverters. The capacity of series and shunt inverters is calculated through loading calculations of these inverters applying phasor diagram to increase the design accuracy.

## **I. INTRODUCTION**

Power quality issues are becoming more and more significant in the sides because of the increasing number of power electronic devices that behave as nonlinear loads. A wide diversity of solution stop power quality problems is available for both the distribution network operator and the end use. The power processing at source, load and for reactive and harmonic compensation by means of power electronic devices is becoming more prevalent due to the vast advantages of feared by them. The shunt active power filter(APF) is usually connected across the loads to compensate for all current related problems such as the reactive power compensation, power factor improvement, current harmonic compensation and load unbalance compensation, whereas the series active power filter is connected in a series with a line through series transformer. It acts as controlled voltage source and can compensate all voltage related problems, such as voltage harmonics, voltage sag, voltages well, flicker, etc.

UPQC is a custom power device and consists of combined series active power filter that compensates voltage harmonics, voltage unbalance, voltage flicker, voltage sag/swell and shunt active power filter that compensates current harmonics, current unbalance and reactive current Unified Power Quality Conditioner is also known as universal power quality conditioning system, the universal active power line conditioner and universal active filter.

# International Journal of Innovative Research in Science, Engineering and Technology

(An ISO 3297: 2007 Certified Organization)

Vol. 4, Special Issue 6, May 2015

UPQC system can be divided into two sections: The control unit and the power circuit. Control unit includes disturbance detection, reference signal generation, gate signal generation and voltage/current measurements. Power circuit consists of two voltage source converters, standby and system protection system, harmonic filters and injection transformers.

Three significant control approaches for unified power quality conditioner can be found to control the sag on the system: 1) active power control approach in which an in phase voltage is injected through series inverter, popularly known as UPQCP 2) reactive power control approach in which quadrature voltage is injected [4],[5] known as UPQCQ and 3) a minimum VA loading approach in which a series voltage is injected at a certain angle, in this paper called as UPQCVA min. Among the fore mentioned three approaches, the quadrature voltage injection requires a maximum series injection voltage, whereas the inphase voltage injection requires the minimum voltage injection magnitude. In a minimum VA loading approach, the series inverter voltage is injected at an optimal angle with respect to the source current.

Since the proposal of the UPFC, there has been increasing interest in finding a suitable control method to suit a range of system operating conditions. Various controllers have been proposed to regulate the operation of UPFC. UPFC for damping power system oscillations an additional PI controller is used along with the UPFC main controller for this purpose. Modeling is achieved in this project by implementing Model Predictive Control Technique and Bacterial Foraging Algorithm. The simulation is carried out in MATLAB/simulink which shows promising results. This is caused by the control parameters being determined based on certain system conditions.

These two types of converter are from the voltage sourced converter (VSC) that implement based on the concept of the solid state synchronous voltages source (SVS). It's consists two VSC with a common dc link. This converter consist the six valve of a gate-turn-on (GTO) parallel with the reverse diode and dc capacitor. An AC voltage is generated from a DC voltage through sequence switching of the GTOs. The DC voltage is unipolar and the DC current can flow freely in either direction. By control the angle of the converter output voltage will control the real power exchange between converter and the AC system. If the output voltage of converter is control to lead the AC system voltage the power flow is from direction DC to AC side (rectifier) whereas if the control is lag the AC system voltage the power flow is in the inverter condition.

## II. CONVERTER AND COMPENSATOR DESCRIPTION

This is a closed loop system. The output of this system is controlled such that to compensate the required voltage sag based on load reactance values. During normal operation the solar power is battery stored and when compensation requirement is availed the source DC is converted to AC by buck boost converter and fed to the load line to compensate voltage sag. The IGBT converter gate is controlled based on Neural Network logic and PI Controller such that gate pulses are generated to coin side the voltage sag compensation.

## III. BUCK BOOST CONVERTOR

The buck–boost converter is a type of DC-to-DC converter that has an output voltage magnitude that is either greater than or less than the input voltage magnitude. Two different topologies are called buck–boost converter. Both of them can produce a range of output voltages, from an output voltage much larger (in absolute magnitude) than the input voltage, down to almost zero.

## IV. THE INVERTING TOPOLOGY

The output voltage is the opposite polarity than the input. This is a switched-mode power supply with a similar circuit topology to the boost converter and the buck converter. The output voltage is adjustable based on the duty cycle of the switching transistor. One possible drawback of this converter is that the switch does not have a terminal at ground; this complicates the driving circuitry. Neither drawback is of any consequence if the power supply is isolated

# International Journal of Innovative Research in Science, Engineering and Technology

(An ISO 3297: 2007 Certified Organization)

Vol. 4, Special Issue 6, May 2015

from the load circuit (if, for example, the supply is a battery) because the supply and diode polarity can simply be reversed. The switch can be on either the ground side or the supply side.

### V. PRINCIPLE OF OPERATION

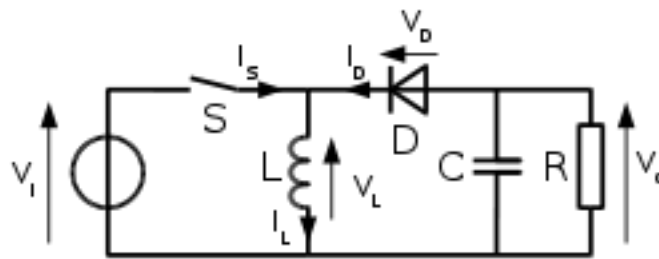

Fig.1. Basic diagram of the buck-boost converter

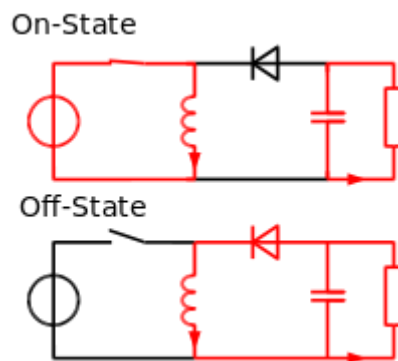

Fig.2. ON and OFF state of the buck-boost converter

The basic principle of the buck-boost converter

- During in On-state, the input voltage source is directly connected to the inductor (L). This results in accumulating energy in L. In this stage, the capacitor supplies energy to the output load.
- During in Off-state, the inductor is connected to the output load and capacitor, so the energy is transferred from L to C and R Compared the buck and boost converters. polarity of the output voltage is opposite to that of the input
- The output voltage can vary continuously from 0 to  $-\infty$  (for an ideal converter). The output voltage ranges for a buck and a boost converter are respectively 0 to  $V_i$  and  $V_i$  to  $\infty$

When the switch is then opened, the inductor will be cut off from the input voltage supply, so the current will tend to drop to zero. Again, the inductor will fight such an abrupt change in current. To do so, it must now act like a voltage source to the rest of the circuit, which it can do using the energy it stored while charging. Since current was previously flowing "down" the inductor, it will want to maintain this direction, and so the voltage that it provides will be inverted relative to input supply. During this time, the inductor will discharge through the load and the rest of the circuit, which will cause its voltage to decrease over time. Also during this time, the capacitor in parallel with the load will charge up to the voltage presented by the inductor.

# International Journal of Innovative Research in Science, Engineering and Technology

(An ISO 3297: 2007 Certified Organization)

Vol. 4, Special Issue 6, May 2015

## Continuous mode Operation

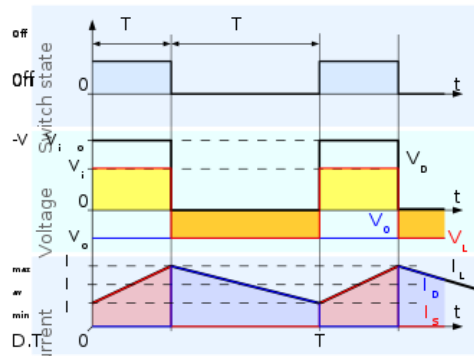

Fig.3.Waveforms of current and voltage in a buck–boost converter operating in continuous mode.

## Discontinuous mode

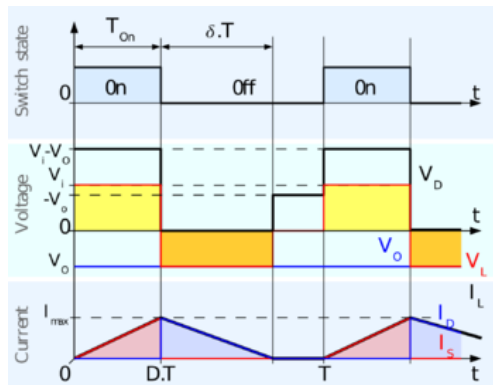

Fig.4.Waveforms of current and voltage in a buck–boost converter operating in discontinuous mode

## TYPICAL PHASOR & LOADING GRAPHS OF UPQC

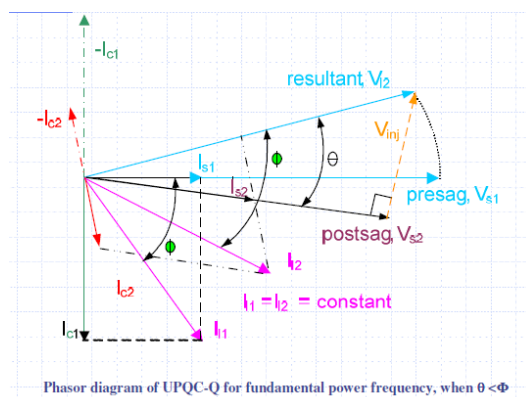

Fig.5.Phasor diagram of UPQC-Q for fundamental for power frequency

## VI. (DC-UPQC) DC LINKED

A structure has been proposed in [4-7], as shown in Figure as where DG sources are connected to a DC link in the UPQC as an energy source. This configuration works both in interconnected and is landed mode (shown in Interconnected mode, DG provides power to the source and loads where as in islanded mode DG (within its power

## International Journal of Innovative Research in Science, Engineering and Technology

(An ISO 3297: 2007 Certified Organization)

Vol. 4, Special Issue 6, May 2015

rating) supplies the power to the load only. In addition, UPQC has the ability to inject power using DG to sensitive loads during source voltage interruption. The advantage of this system is voltage interruption compensation and active power injection to the grid in addition to the other normal UPQC abilities. The system's functionality may be compromised if the DG resources are not sufficient during the voltage interruption conditions. Economical operation of the system can also be achieved by proper controlling of active power transfer between the supply and DG source through a series APF [7]. The proposed system can also reduce the investment cost by nearly one fifth if the UPQC and DG are used separately [8].

A typical application of a UPQC might be to overcome the grid integration problems of the DG, such as the fixed-speed induction generator (FSIG) as investigated in [11]. The FSIG fails to remain connected to the grid in the event of a grid voltage dipper line fault due to excessive reactive power requirement. This type of UPQC is referred to as left shunt UPQC [13]. Based on the research study, in addition to the normal functionality of UPQC, some of the other advantages and disadvantages have been identified for the techniques

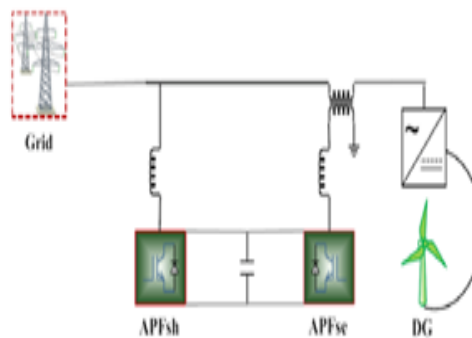

Fig.6. Grid connected wind energy system with UPQC

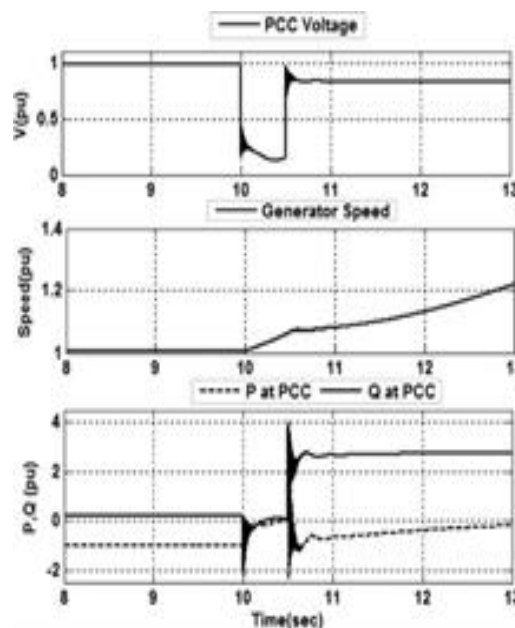

Fig.7. Generator response to a three-phase fault without UPQC

# International Journal of Innovative Research in Science, Engineering and Technology

(An ISO 3297: 2007 Certified Organization)

Vol. 4, Special Issue 6, May 2015

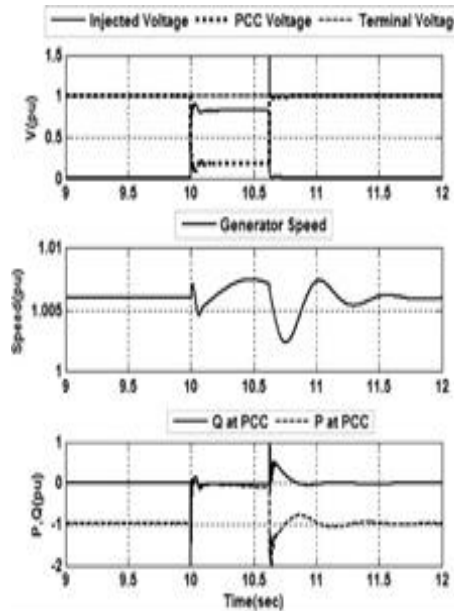

Fig.8. Generator response to a three-phase fault with UPQC

## VII. UPQC – UNIFIES POWER QUALITY CONDITIONER

UPQC can compensate for almost all existing PQ problems in the transmission and distribution grid, placement of a UPQC in the distributed generation network can be multipurpose. As a part of integration of UPQC in DG systems, research has been done on the following two techniques: DC-Linked and Separated DG- UPQC systems.

UPQC is the integration of series (APFse) and shunt (APFsh) active power filters, connected back-to-back on the dc side, sharing a common DC capacitor [8], shown in Figure 5. The series component of the UPQC is responsible for mitigation of the supply side disturbances: voltage sags/swells, flicker, voltage unbalance and harmonics. It inserts voltages as to maintain the load voltage state desired level; balanced and distortion free. The shunt component is responsible for mitigating the current quality problems caused by the consumer: poor power factor, load harmonic currents, loads unbalance etc., It injects currents in the ac system such that the source currents become balanced sinusoids and in phase with the source voltages. The overall function of UPQC mainly depends on the series and shunt APF controller.

## VIII. UPQC IN DOUBLE FEEDER DISTRIBUTION SYSTEM

A new connection proposal for UPQC, to improve the power quality of two feeders in a distribution system has been made in which is termed Interline UPQC (IUPQC). The purpose of the IUPQC is to hold the feeder voltages constant against voltage sag/swell and temporary interruption in either of the two feeders. It has been demonstrated that the IUPQC can absorb power from one feeder to hold the other feeder voltage constant in case of a voltage sag in the other source voltage. This UPQC can also be implemented in a custom power park or micro grid system. This can further be improved as a multi-converter based UPQC [16] where multiple VSI are connected back to back on the dc side

These multi-module techniques allow the symmetrical distribution of the load power among the components of the topology, but the classical design procedure must be modified or refined to ensure the power cell components should be within its maximum ratings. Therefore, an design procedure of UPQC with a feature of extending capacity based on a modular approach is presented in [12-13], shown in Figure, where H-bridge power cells are added in each single phase arrangement depending on the required compensating power.

# International Journal of Innovative Research in Science, Engineering and Technology

(An ISO 3297: 2007 Certified Organization)

Vol. 4, Special Issue 6, May 2015

## IX. UPQC SIMULATION SHOWING BLOCKS

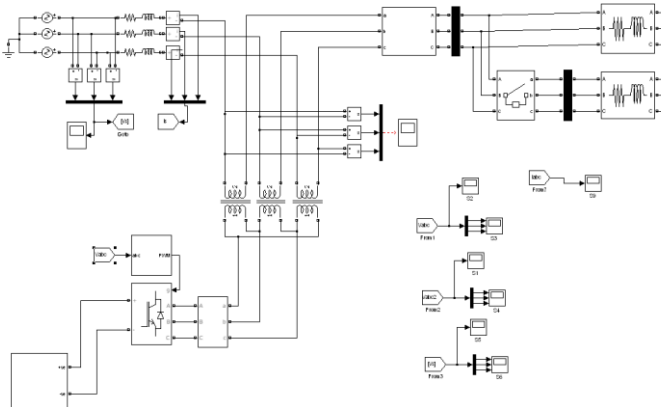

## X. SIMULATION DIAGRAM OF BUCK-BOOST CONVERTOR

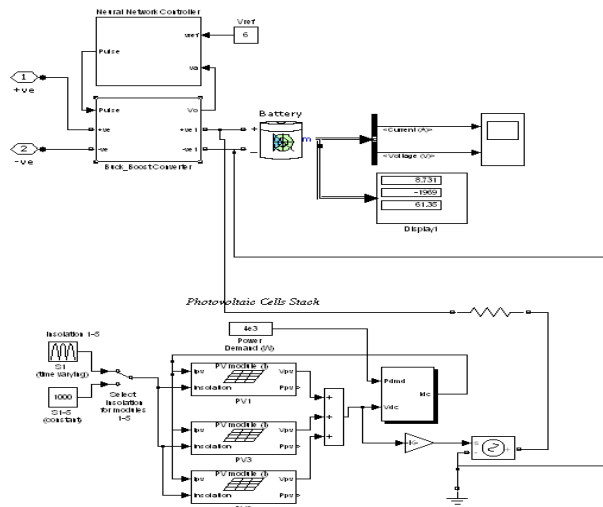

## XI. SIMULATION RESULTS

The performance of the proposed concept of simultaneous voltage sag compensation has been evaluated by simulation. To analyze the performance of UPQC the source is assumed to be pure sinusoidal. For better visualization of results the load is considered as highly inductive.

Scope – S5

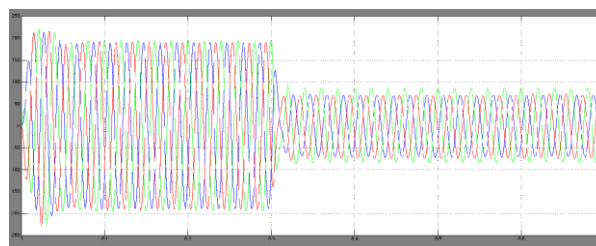

Scope –S3

# International Journal of Innovative Research in Science, Engineering and Technology

(An ISO 3297: 2007 Certified Organization)

Vol. 4, Special Issue 6, May 2015

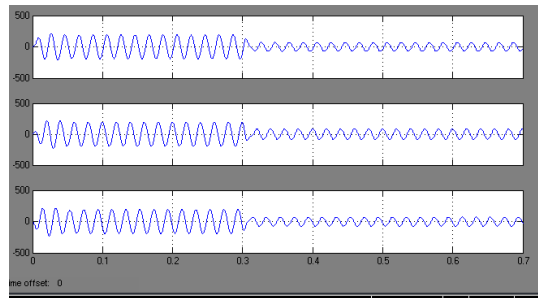

Scope S12

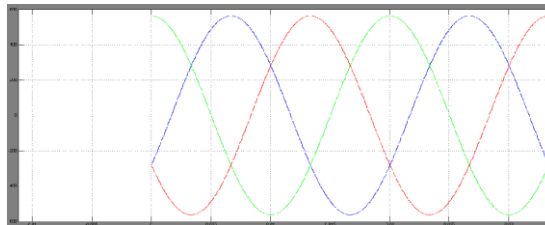

Scope -S6

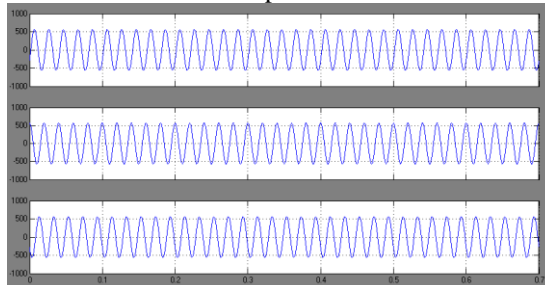

Scope S8

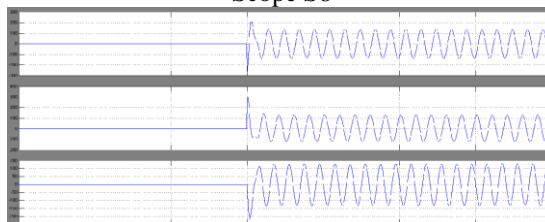

Scope - S9

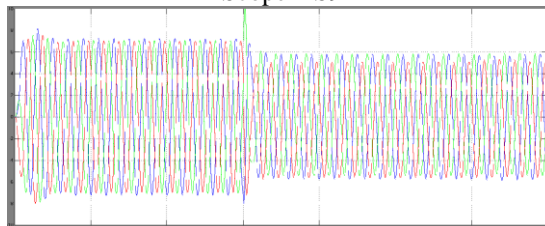

Scope - S15



# International Journal of Innovative Research in Science, Engineering and Technology

(An ISO 3297: 2007 Certified Organization)

Vol. 4, Special Issue 6, May 2015

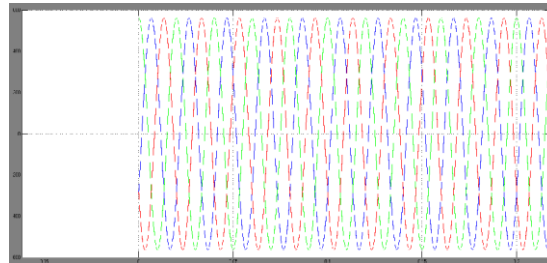

## XII. CONCLUSION

A new concept of controlling complex voltage sag through using solar power compensation by converter topology based on Artificial Neural Network is introduced and named as UPQC. The proposed concept of the UPQC approach is mathematically formulated and analyzed for voltage sag and swell conditions. The developed comprehensive equations for UPQC-S can be utilized to estimate the required series injection voltage and the shunt compensating Current profiles (magnitude and phase angle), and the overall VA loading both under voltage sag and swell conditions. The simulation and experimental studies demonstrate the effectiveness.

## REFERENCES

- [1] R. C. Dugan, M. F. McGranaghan, and H. W. Beaty, *Electrical Power Systems Quality*. New York: McGraw-Hill, 1996, p. 265.
- [2] C. Sankaran, *Power Quality*. Boca Raton, FL: CRC Press, 2002, p. 202.
- [3] R. A. Walling, R. Saint, R. C. Dugan, J. Burke, and L. A. Kojovic, "Summary of distributed resources impact on power delivery systems," *IEEE Trans. Power Del.*, vol. 23, no. 3, pp. 1636–1644, Jul. 2008.
- [4] L. Gyugyi, "Unified power-flow control concept for flexible AC transmission systems," *IEEE – C Gene. Trans. Distr.*, vol. 139, no. 4, pp. 323–331, Jul. 1992.
- [5] N. G. Hingorani and L. Gyugyi, *Understanding FACTS: Concepts and Technology of Flexible AC Transmission Systems*. New York: IEEE Press, 2000, p. 432.
- [6] C. Nagarajan and M. Madheswaran - 'Performance Analysis of LCL-T Resonant Converter with Fuzzy/PID Using State Space Analysis' - Springer, *Electrical Engineering*, Vol.93, March 2011.
- [7] C. Nagarajan and M. Madheswaran, *Stability Analysis of Series Parallel Resonant Converter with Fuzzy Logic Controller Using State Space Techniques*, Taylor & Francis, *Electric Power Components and Systems*, Vol.39 (8), pp.780-793, 2011.
- [8] C. Nagarajan and M. Madheswaran - 'Experimental verification and stability state space analysis of CLL-T Series Parallel Resonant Converter' - *Journal of ELECTRICAL ENGINEERING*, Vol.63 (6), pp.365-372, Dec.2012.
- [9] C. Nagarajan and M. Madheswaran - 'Analysis and Implementation of LLC-T Series Parallel Resonant Converter with Fuzzy controller' - *International Journal of Engineering Science and Technology (IJEST)*, Applied Power Electronics and Intelligent Motion Control. Vol.2 (10), pp 35-43, December 2010
- [10] C. Nagarajan and M. Madheswaran - 'Performance Estimation of LCL-T Resonant Converter with Fuzzy / PID Controller' - *International Journal of Computer and Electronic Engineering (IJCEE)*, Vol.2 (3), pp.534-542, June 2010
- [11] C. Nagarajan, M. Madheswaran and D. Ramasubramanian - 'Development of DSP based Robust Control Method for General Resonant Converter Topologies using Transfer Function Model' - *Acta Electrotechnica et Informatica Journal*, Vol.13 (2), pp.18-31, April-June.2013
- [12] C. Nagarajan and M. Madheswaran - 'DSP Based Fuzzy Controller for Series Parallel Resonant converter' - Springer, *Frontiers of Electrical and Electronic Engineering*, Vol. 7(4), pp. 438-446, Dec.12.
- [13] C. Nagarajan and M. Madheswaran - 'Experimental Study and steady state stability analysis of CLL-T Series Parallel Resonant Converter with Fuzzy controller using State Space Analysis' - *Iranian Journal of Electrical & Electronic Engineering*, Vol.8 (3), pp.259-267, September 2012.
- [14] V. K. Sood, *HVDC and FACTS Controllers – Applications of Static Converters in Power Systems*. Boston, MA: Kluwer, 2004, p. 295.