

# International Journal of Innovative Research in Science, Engineering and Technology

(An ISO 3297: 2007 Certified Organization)

Vol. 4, Special Issue 6, May 2015

## Gesture Controlled Wheel Chair Robot

R.Bhuvaneshwari<sup>1</sup>, M.Chandramohan<sup>2</sup>

PG Scholar, Department of EEE, Gnanamani College of Technology, Nammakal, Tamilnadu, India<sup>1</sup>

Associate Professor, Department of EEE, Gnanamani College of Technology, Nammakal, India<sup>2</sup>

**ABSTRACT:** The goal of this project is to regulate the disabled persons to move from one place to another place using gesture wheel chair robot. Gesture recognition technologies are using for the control of the robot to move from one place to another. Several approaches have been developed for sensing gesture and controlling robots. Glove based technique is a well-known means of recognizing hand gestures. It utilizes a tilt sensor attached to a glove that directly measures hand movements, few robotic systems are used with user friendly interfaces that possess the ability to control the robot by natural means. To facilitate a feasible solution to this requirement, we have implemented a system through which the user can give commands to a wireless robot using gestures.

**KEYWORDS:** Gestures,Arduino,Infrared,LED.

### I INTRODUCTION

The motivation behind this project resides in creating low-cost products for medical applications including medical instruments required for diagnosing psychological diseases and instruments for aiding paralyzed patients. Basic tasks could be jobs that are harmful to the human, repetitive jobs that are boring, stressful etc. Though robots can be a replacement to humans, they still need to be controlled by humans itself. Robots can be wired or wireless, both having a controller device. Both have pros and cons associated with them. Beyond controlling the robotic system through physical devices, recent method of gesture control has become very popular. The main purpose of using gestures is that it provides a more natural way of controlling and provides a rich and intuitive form of interaction with the robotic system. This mainly involves image processing and machine learning for the system or application development. Beyond this, it also requires some kind of hardware for interfacing with the system for gesture control. There are some systems that have been developed in the same field using various techniques. This design can be implemented to control wheelchair by using tilt sensor. This technology can help patients suffering from psychological disease. The Monitor can be implemented using the design of the wheel chair robot. This Monitor will Monitor and determine the nature of the disease. Sleep deprivation has become the focus of health and safety concern.

### II. DESIGN CONSIDERED

There are multiple parts of this project. The main goal was to develop a robot with all of the aforementioned capabilities. The overall system design was divided into four inter connected subsystems as shown in figure1.

The four subsystems and there desired functions are:

1. Monitoring System: This system records activity using an tilt sensor. The main goal of this system is to perform signal processing on the raw signal obtained. This is achieved by filtering the original signal by passing through multiple band-pass filters. These filters output are then input to an analog-to-digital converter and are digitized. Further processing is performed are arranged in discrete data packets. These packets are serially transferred to the Processing Unit.

## International Journal of Innovative Research in Science, Engineering and Technology

(An ISO 3297: 2007 Certified Organization)

Vol. 4, Special Issue 6, May 2015

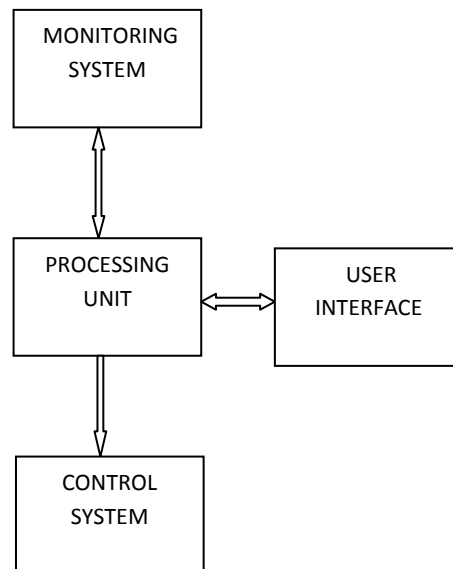

Figure 1 Interconnected Subsystem

2. Processing Unit: This unit acts as the brain of the robot. It communicates with all other subsystems and initializes them. The desired function of this system is to obtain digitized signal including attention and meditation level from Monitoring System and determine the direction and motion of the robot. The motion and direction data is then output to Control System. This system verifies functionality of other systems on reset and notify user if there are any errors. This system is also responsible for detecting any obstacles in the path of motion. It changes the direction of the robot if it detects an edge of surface it is moving on or any obstacle in its path.

3. Control System: This system is responsible to control the motion of the robot. The desired function of this system is to take digital information pertaining to robot motion and direction from the Processing System and move the robot accordingly.

4. User Interface (UI) System: The goal of this system is to provide essential functions to user to control the operation of the Mind Control Robot. It displays mind attention or mediation level on an array of LEDs. User can change the mode of operation using input peripherals of the UI system. This system informs the user when the mode of operation is changed and also alert user if an error has occurred. Each subsystem is individually designed and tested. A comprehensive part evaluation for each subsystem was performed and suitable components were chosen which are reliable and also cost-effective. The components of each unit and their functions are:

#### A. Accelerometer

An Accelerometer is a sensor which gives an analog data while moving in X,Y,Z direction or may be X,Y direction only depends on the type of the sensor. Here is a small image of an Accelerometer shown in figure 2. We can see in the image that there are some arrows showing if we tilt these sensors in that direction then the data at that corresponding pin will change in the analog form.

#### B. Microcontroller

The microcontroller is the most important component of the Processing System. There are many microcontrollers available that can be used for this subsystem. For this project Arduino Uno was chosen. Arduino Uno is microcontroller board based on ATMEGA328. It provides 14 digital I/O pins and 6 analog I/O pins which are sufficient for this project. The Arduino Uno operates at 16 MHz at reset, Arduino initializes all other subsystems. The Arduino takes digital data from USB dongle and store it in an array for further processing. The firmware then takes these data packets and parses them to obtain mind attention and meditation level. This approach is further explained in software section. The Arduino determines the status of the robot and computes the direction of the motion. This information is stored in digital packets. The Arduino outputs these packets to User Interface (UI) subsystem and Motion Control subsystem.

# International Journal of Innovative Research in Science, Engineering and Technology

(An ISO 3297: 2007 Certified Organization)

Vol. 4, Special Issue 6, May 2015



Figure 2 accelerometer

### C. H-Bridge

The H-bridge was used to drive DC motors. It provides bidirectional drive currents up to 1 A enabling motor to turn in either direction. For this project H-bridge IC manufactured by Texas Instruments was used. The H-bridge takes digital data from Arduino and drives the DC motor accordingly. The Arduino outputs two data signals for each DC motor and one control signal to enable the IC. The functions of these signals are shown in table 1.

Table 1 H-Bridge Control Signals

EN	1A	2A	Function
H	L	H	Turn Right
H	H	L	Turn Left
H	L	L	Fast motor stop
H	H	H	Fast motor stop
L	X	X	Fast motor stop

H = High, L = Low, X = Don't Care

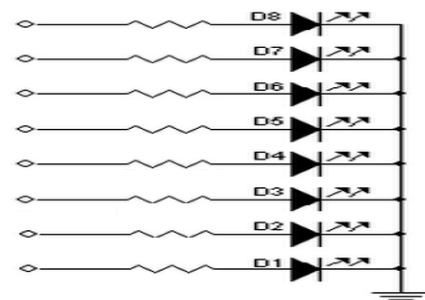

Figure 3 LED Bar-Graphs and SIP Resistor Network

### F. SIP Resistor Network

The resistor network was connected between LED Bar- Graph and the input of User Interface (UI) subsystem as shown in figure 3. These resistors limit current through LEDs and save them from burning out.

### G. LED Bar-Graph

The LED Bar-Graph is used to display the movement of wheelchair robot. The first 5 LEDs represent direction of control of wheel chair robot. The remaining LEDs are reserved to notify user about any error occur in the system including failure of subsystems.

### H. Dual in-line (DIP) switches

Two Dual in-line (DIP) switches were used to determine the mode of operation. These two switches represent two binary bits. Two bits provide 4 different binary numbers from 0 to 4. Each binary number is associated with different mode of operation.

### H. Buzzer

A buzzer is used to alert user regarding the motion of Robot. It sounds before making turn or changing the direction of motion. It also notifies user when all subsystems pass or fail Power on Self Tests (POSTs).

### I. Ultrasonic Distance Measuring Sensor

The ultrasonic distance measuring sensor is used to detect any obstacles in the path of robot. This sensor provides precise, non-contact distance measurements within 2 cm to 3m range. This sensor outputs distance measurements once every second to Arduino. The Arduino stops and turns the robot if the distance of near obstacles is less than 5 cm.

### J. Infrared (IR) Line Sensor

This sensor is used to detect edge of the surface the robot is moving on. This sensor relies on the reflected wave in order to determine the edge. It notifies the processing unit by generating an interrupt. The Interrupt Service Routine (IRS) stops and turns the robot in order to avoid falling.

# International Journal of Innovative Research in Science, Engineering and Technology

(An ISO 3297: 2007 Certified Organization)

Vol. 4, Special Issue 6, May 2015

## III. IMPLEMENTATION

### A. Capturing Gesture Movements:

Image frame is taken as input from the webcam on the control station is done on each input frame to detect hand palm. Figure 4 is an example of input frame. This involves some background constraints to identify the hand palm correctly with minimum noise in the image.

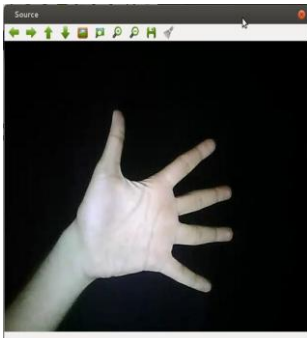

Figure 4. Input Image Frame

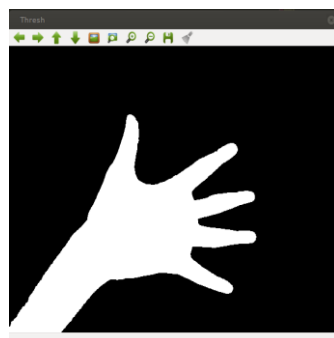

Figure 5. Image Thresholding

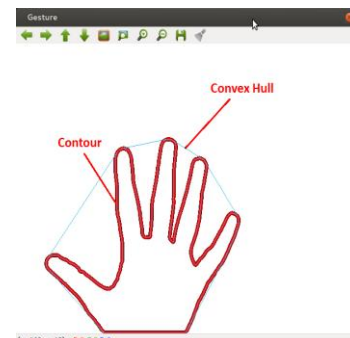

Figure 6. Contour and Convex Hull

### B. Hand Palm Detection

After capturing the image frame from the webcam operations are performed on this frame to prepare it for the process of command detection. These operations are necessary for implementing the techniques of gesture control the following two main processes are to be carried out for detecting the hand palm.

#### 1) Thresholded Image:

Image frame taken as input from webcam is thresholded and starting from minimum thresh value till single contour is formed in an image as same as in the case of intensity based thresholding. In the Figure 5 two fingers are shown by the user as a gesture command having dark background. That image is thresholded so that only a single contour can be formed on it. This thresholding is to be carried out on the basis of intensity in the image which neglects the dark background and thresholds the fingers. Thresholded image is shown in Figure number 5.

#### 2) Drawing Contour and Convex Hull:

As shown in Figure 6 the obtaining thresholded image two main things are done, drawing the Contour on the thresholded part and fitting this contour in the Convex Hull. Contour is drawn in the thresholded image by using function drawContour(). This is done on the intermediate image is then passed for drawing the convex hull. This covers the whole contour by joining the minimal points to form Convex Hull. These two basic operations are performed on every image frame taken from the webcam then depending on the kind of gesture technique chosen by the user for further process on the images are to be carried out. These two techniques are Finger Count based gesture control and Direction of Hand Palm Gesture Control.

### C. Command Detection using Specific Method:

After completion of pre-processing of an input frame, further process to be carried out on the extracted image according to specified technique. These two methods of giving gesture commands are as follows.

#### 1) Finger Count based Gesture Control:

In this technique of giving gesture commands it first defects in the convex hull are found out using function ConvexityDefects(). Convex hull is formed using minimal set of points so it does follow the contour path always this causes the formation of defects in the convex hull. ConvexityDefects() function gives information about these defects stored in the form of vector. This vector has values of each defect point in the coordinate format at end points of the line of defect and depth of the defect point. The non-linear structure of the contour causes hundreds of defects for the convex hull. But the defect formed due to gap between two fingers has largest depth value as compared to other depth values of defects. Minimum threshold value is considered for the comparison with all depth values thus the depth

# International Journal of Innovative Research in Science, Engineering and Technology

(An ISO 3297: 2007 Certified Organization)

Vol. 4, Special Issue 6, May 2015

values more than this threshold value would be the depth point of a defect which would be formed due to gaps between two fingers. This is well applicable for the count two to five. As for the 1 such depth count of finger will be 2 i.e. depth plus one and so on. In the Figure 7 two fingers are shown having only one depth point so for that one depth point count is two. Also in Figure 8 same techniques are used to show a different command. After processing the image two defects are found out that specifies count as 3.

This technique has some disadvantages so another technique can be used.

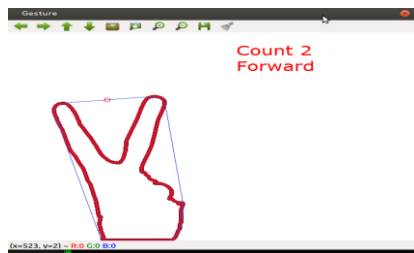

Figure 7 Finger Count based Gesture Control I

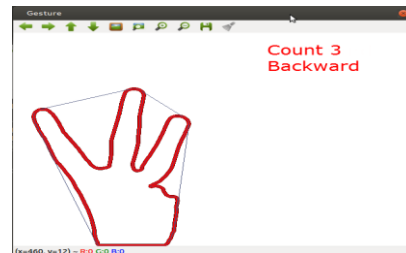

Figure 8 Finger Count based Gesture Control II

## 2) Direction of Hand Palm:

In the previous technique of Finger Count Gesture Control the image having no large depth fails. For example, for finger count one, there is no such large depth so it is difficult to recognize that it is count one or there is no such count. So counts from two to five are used as command signals. In this technique of gesture command, orientation of hand palm is taken into the consideration for recognition of the command signal. Thus an orientation of hand palm gives direction in which robot is to be moved. This command can be given with minimum two fingers or with the whole palm. In the Figure 9, gesture command of this technique is given using two fingers.

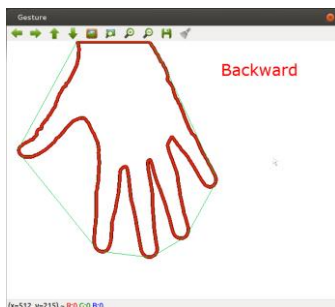

Figure 9 Direction of Hand Palm I

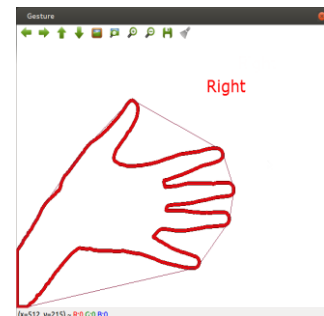

Figure 10 Direction of Hand Palm II

For the difference between y-coordinate of the point, which is negative, orientation is in the left direction specifying command as left. Similarly in the above Figure 13, the orientation of two fingers is down, that is a command given to the robot is backward. In this image frame, there is a small change in x-coordinate and large positive change in y-coordinate of the depth point and midpoint of the line of defect. So the orientation of the two fingers is downwards, specifying command as backward. Similarly for the difference between y-coordinate of the point as negative, orientation is in the upward direction specifying command as forward.

## G. Motor Driver: L293D

L293D motor driver circuit is shown in the Figure 11. It takes digital signal as an input from the Arduino and gives digital output to the DC motors of the robot. Power supply to the circuit is given by rechargeable batteries. In this system some rechargeable mobile batteries are used as power supply each of 3.7V. To provide more voltage to drive the motors, 2-3 such batteries are connected in series.

## International Journal of Innovative Research in Science, Engineering and Technology

(An ISO 3297: 2007 Certified Organization)

Vol. 4, Special Issue 6, May 2015

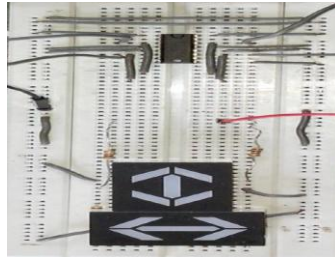

Figure 11. Motor Driver Circuit

The motor driver is a monolithic, integrated, high voltage and high current which has 4 channel drivers. Basically this means using this chip one could use at most four DC motors and provide power supplies of up to 36V. The L293D chip uses H-Bridge. The H-Bridge is typically an electrical circuit that enables a voltage to be applied across a load in either direction to an dc motor. This means that just reversing the direction of current leads to reversing of the direction of motor.

### H. DC Motors in Robot:

This is the final end product of robot consisting of all the hardware WiFly, Arduino and L293D motor Driver circuit on the robot chassis having power supply provided by the rechargeable batteries. Four DC motors are connected to this robot chassis as shown in Figure 16. This is controlled through gestures by the user at control station.

### K. Software

The Arduino Integrated Development Environment (IDE) was used to program Arduino. This IDE is a cross-platform application written in Java and is derived from the IDE for the processing programming language. The firmware developed for this project allows Arduino to communicate with other subsystems. This firmware stores and parses digital data to obtain These levels are further scaled to display on LED Bar-Graph. The firmware also reports any error it encounters during execution. A Gesture Controlled robot is a kind of robot which can be controlled by hand gestures and not the old fashioned way by using buttons. The user just needs to wear a small transmitting device on his hand which includes a sensor which is an accelerometer in our case. Movement of the hand in a specific direction will transmit a command to the robot which will then move in a specific direction. The transmitting device includes a Comparator IC for assigning proper levels to the input voltages from the accelerometer and an Encoder IC which is used to encode the four bit data and then it will be transmitted by an RF Transmitter module. At the receiving end an RF Receiver module will receive the encoded data and decode it by using a decoder IC. This data is then processed by a microcontroller and passed onto a motor driver to rotate the motors in a special configuration to make the robot move in the same direction as that of the hand. The attention and meditation levels are divided into 5 sub-levels. Each sub-level is indicated on Bar-Graph by turning the corresponding LED on. Level 1 is represented by single LED while level 5 is represented by turning all 5 LEDs.

## III. FINAL DESIGN

The final design of mind control robot includes all aforementioned components. All subsystems discussed above were assembled and tested separately. At reset, the wheelchair Robot, shown in Figure 12. The robot which can be controlled by our hand gestures not by old buttons. We just need to wear a small transmitting device in our hand which included an acceleration meter. This will transmit an appropriate command to the robot so that it can do whatever we want. The transmitting device included a comparator IC for analog to digital conversion and an encoder IC which is use to encode the four bit data and then it will transmit by an RF Transmitter module. At the receiving end an RF Receiver module receives's the encoded data and decode it by an decoder IC. This data is then processed by a microcontroller and finally our motor driver to control the motor.



# International Journal of Innovative Research in Science, Engineering and Technology

(An ISO 3297: 2007 Certified Organization)

Vol. 4, Special Issue 6, May 2015

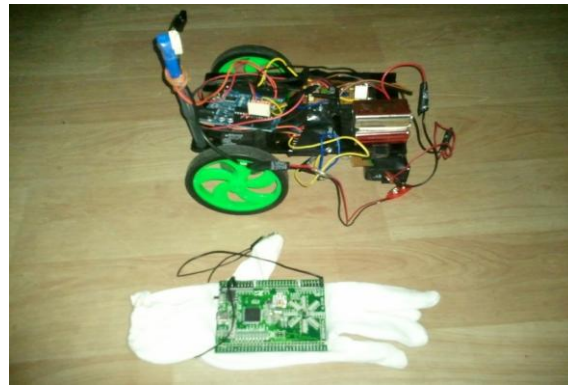

Figure 12 Gesture Control Wheelchair Robot

The system user operates the robot from a control station that can be a laptop or a PC with a good quality in-built webcam or external webcam. This webcam is used to capture real time video stream of hand gestures to generate commands for the robot. Gesture commands are given using hand palm. The gesture technique is used to move robot in all possible directions which are Forward, Backward, Right and Left as a command. The design of the project is shown by the figure 13.

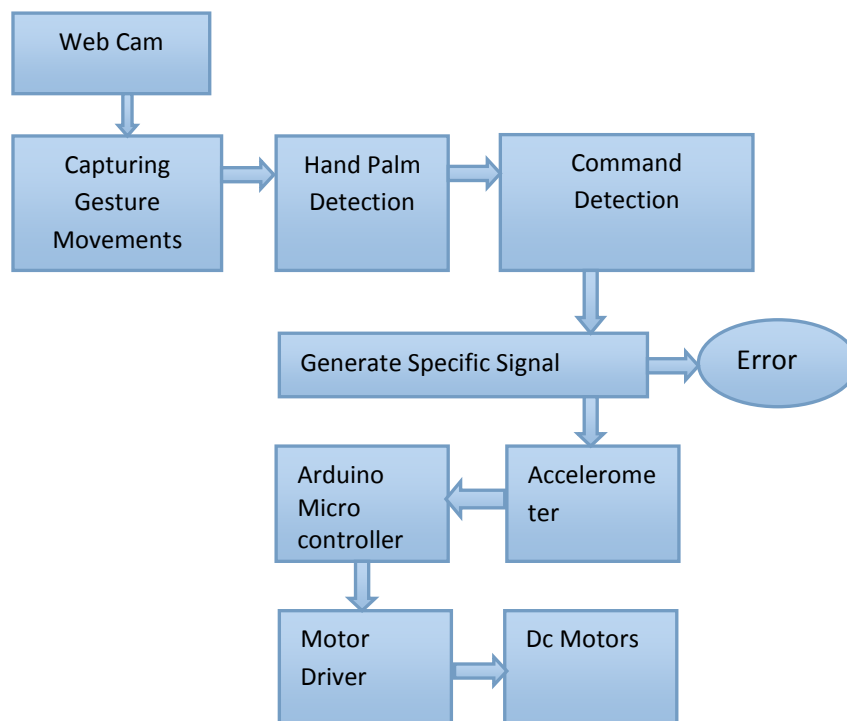

Figure 13 System Design

## IV CONCLUSION

The Gesture Controlled Robot System gives an alternative way of controlling robots. Gesture control being a more natural way of controlling devices makes control of robots more efficient and easy. We have provided two techniques

# International Journal of Innovative Research in Science, Engineering and Technology

*(An ISO 3297: 2007 Certified Organization)*

**Vol. 4, Special Issue 6, May 2015**

for giving gesture input, finger count based gesture control and direction of hand palm based gesture control. In which each finger count specifies the command for the robot to navigate in specific direction in the environment and direction based technique directly gives the direction in which robot is to be moved. At a time any one of the method can be used according to user's reliability, without using any external hardware support for gesture input unlike specified existing system. After gesture recognition command signal is generated and passed to the robot and it moves in specified direction.

## REFERENCES

- [1] Chao Hy Xiang Wang, Mrinal K. Mandal, Max Meng, and Donglin Li, "Efficient Face and Gesture Recognition Techniques for Robot Control", CCECE, 1757-1762, 2003.
- [2] Asanterabi Malima, Erol Ozgur, and Mujdat Cetin, "A Fast Algorithm for Vision-Based Hand Gesture Recognition for Robot Control", IEEE International Conference on Computer Vision, 2006.
- [3] Thomas G. Zimmerman, Jaron Lanier, Chuck Blanchard, Steve Bryson and Young Harvill, "A Hand Gesture Interface Device", 189-192, 1987.
- [4] Jagdish Lal Raheja, Radhey Shyam, Umesh Kumar and P Bhanu Prasad, "Real-Time Robotic Hand Control using Hand Gestures", Second International Conference on Machine Learning and Computing, 2010.
- [5] Gesture Controlled Robot using Kinect <http://www.e-yantra.org/home/projects/wiki/item/180-gesture-controlled-robot-using-firebirdv-and-kinect>
- [6] S.K.L. Lal and A. Craig, "A critical review of the psychophysiology of driver fatigue", Biological Psychology, vol. 55, pp. 173 -194, 2001.
- [7] Arduino Uno, <http://arduino.cc/en/Main/arduinoBoardUno>.
- [8] Arduino Development Environment, [arduino.cc/en/guide/Environment](http://arduino.cc/en/guide/Environment)
- [9] ThinkGear Communications Protocol, [http://developer.neurosky.com/docs/doku.php?id=thinkgear\\_communications\\_protocol](http://developer.neurosky.com/docs/doku.php?id=thinkgear_communications_protocol)