

Music Listening Behaviour Tracking: Active Learning Approach

Krishna Kanta Maiti, Arkaprava Midya

Asst. Professor, Department of Computer Science Engineering, Modern Institute of Engineering & Technology,
Bandel, West Bengal, India

Software Engineer, ARC Infotech, Kolkata, West Bengal, India

ABSTRACT: Music listening has become a way of relaxation due to the portability of music playing device today. People enjoy their favorite tracks almost every time. The motivation is to understand the user's behavior towards the every track she/he plays and formulate a pattern of her/his taste of listening. Active learning approach is used here to collect the information of every track played. Collected data are then classified to provide a list of track as per user's choice for that time.

KEYWORDS: Active Learning, Oracle, Track

I. INTRODUCTION

Portable devices give the flexibility to listen music every time whenever a user wants to. User's intervention towards listening habit could be tracked and that information could be used for music classification. Music classification as such is a tiresome job for low processing power devices. Here, the oracle's behaviour is classified for each track she/he plays.

In classification, one of the vital problems is to provide sufficient and appropriate data as training samples (labelled data-points). But it is very challenging to find sufficient and appropriate data for learning. Active learning is the process where the data is selected by the learner. With fewer labelled training instances chosen from training dataset, Active Learning Approach can achieve better approximation of accuracy in machine learning. By querying the human annotator, Active learning systems aim to label the unlabelled instance to prevail over the labelling bottleneck. Among various machine learning problems, Active learning Approach takes the challenge to obtain the labelling of the abundant but scarce or expensive data. Qi et. al [1] have proposed a two-dimensional active learning scheme and show its application in image classification. In binary classification, traditional active learning methods select samples only along the sample dimension. But, in multi-label classification, they argued that, for each selected sample, only a part of more effective labels are necessary to be annotated while others can be inferred by exploring the correlations among the labels. Joshi et. al [2] proposed a method of multi-class active learning for classification of image. Iterative active learning algorithm is used for selecting unlabeled examples for the user to label, so that human effort is focused on labelling the most "useful" examples. Using the proposed strategy the track playing behaviour is recorded and evaluated the performance of the proposed active learning strategy.

II. BEHAVIOUR TRACKING

In learning phase, user's activity towards every track, data like track genre, duration of actual play, time of play, volume etc are recorded in our system. Collected information is used for classification purpose. While a user playing the track, our system aims to automatically collect that information without user's notice. System gets learned every time it plays track.

III. ACTIVE LEARNING

Active learning (sometimes called "query learning" or "optimal experimental design" in the statistics literature) is a subfield of machine learning and, more generally, artificial intelligence. The main hypothesis is that if the learning

algorithm chooses the unlabelled data from which it learns—it will perform better with less training., It must often be trained on hundreds (even thousands) of labelled instances to perform any supervised learning system better. An oracle (e.g., a human annotator) plays active role to label the unlabeled instances in the form of asking queries. In this way, the active learner aims to acquire high precision using as few labelled instances as possible, thereby minimizing the cost of obtaining labelled data. Active learning is well-accepted approach in many machine learning problems where data may be plentiful but labelling of data is expensive. There are several scenarios in which active learners may pose queries, and there are also several different query strategies that have been used to decide which instances are most informative. *Figure (1)* illustrates the pool-based active learning cycle, one of the most commonly used technique where a learner may begin with a small number of instances in the labelled training set L , request labels for one or more carefully selected instances, learn from the query results, and then leverage its new knowledge to choose which instances to query next. The newly labelled instance is then simply added to the labelled set ζ , and the learner proceeds from there in a standard supervised way [3]. An item is considered to be a multi-dimensional input variable and is denoted by a vector x (also referred to as a data point). The set of all items are represented by X . The preferences of a user U are denoted by a function f_U (also referred to as a target function); for brevity, we use f when referring to a target user. A rating of an item x is considered to be an output value (or label) and is denoted as $y = f(x)$. Each item x could be rated on a finite scale $Y = 1, 2, \dots, 5$. In supervised learning, the items and corresponding user ratings are often partitioned into complementary subsets – a training set and a testing set (also called a validation set). The task of supervised learning is then too, given a training set (often supplemented by the ratings of all users); learn a function b_f that accurately approximates a user’s preferences. Items that belong to the training set are denoted by X (Train), and these items along with their corresponding ratings constitute a training set, i.e. $\tau = (x_i, y_i)_{x_i \in X}$ (Train) [4].

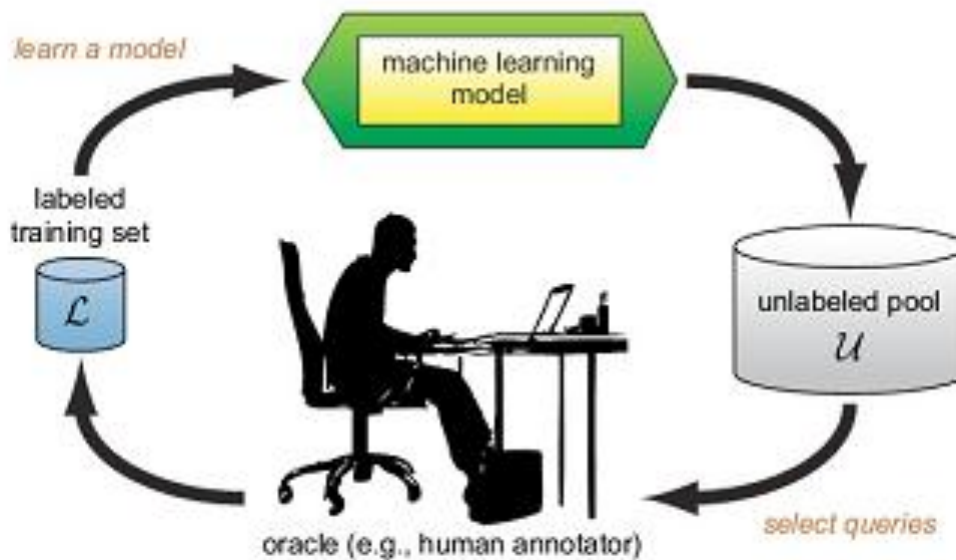

Fig. 1 The pool-based active learning cycle

IV. PROPOSED SYSTEM

In our proposed system, oracle’s activity towards each track is collected. Initially, each track is classified according to the genre of the song. As the system continues, the user’s behaviour is recorded to each and every track, she/he plays. In Active Learning Phase, collect those information as shown in the figure(2). These data are then classified using standard classification approach (i.e., Minimum Distance Classifier). The classified list of tracks is provided to the user as her/his preferences on that time slice.

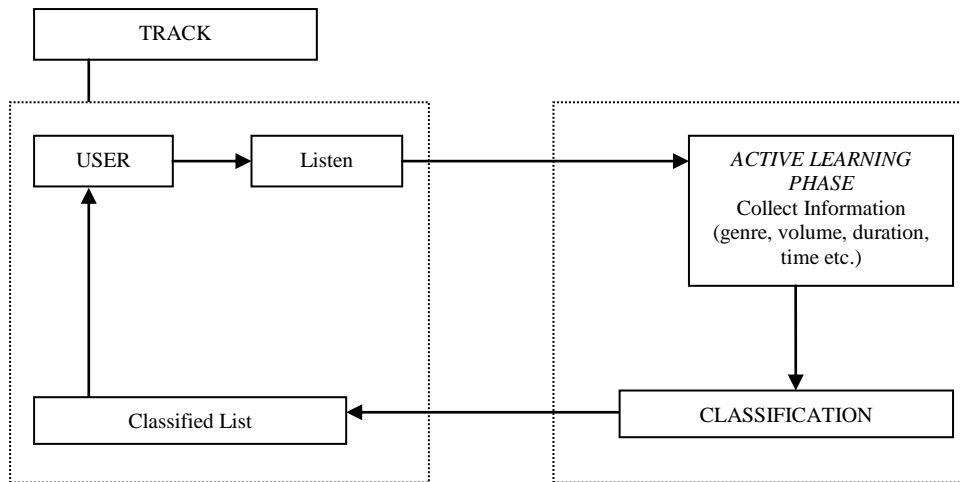

Fig. 2 Flow Chart of Proposed System

Algorithm:

- STEP 1:** User listen track according to her/his interest in our system.
- STEP 2:** System collect information like : genre, volume, duration, time etc during listening of the track.
- STEP 3:** Apply classification (MDC) on the collected information.
- STEP 4:** Generate suggested list of track to the user.
- STEP 5:** Repeat step 1 to step 4 until Oracle's preference.

V.CONCLUSION

In each play, the system got learned with the behaviour as well as taste of listening. Initial classification of behaviour is rendered to the system depending on the single feature i.e., genre of the track and the system get experienced with the increase of activity in the application. The recorded data is then being classified by standard supervised classification technique. Oracle's activity is tracked throughout the application for active learning of the system. After acquiring the enough data, system would be smart to produce the list of tracks according user's taste and mood of listening. Here, we have used Minimum Distance Classifier for classification of the data. Other classification approach can also be tried to learn user's listening habit.

REFERENCES

- [1] Guo-Jun Qi, Xian-Sheng Hua, Yong Rui, Jinhui Tang, and Hong-Jiang Zhang. Two-dimensional active learning for image classification. In Proceedings of IEEE Conference on Computer Vision and Pattern Recognition, pages 1–8, 2008.
- [2] Ajay J. Joshi, Fatih Porikli, and Nikolaos Papanikolopoulos. Multi-class active learning for image classification. In Proceedings of IEEE Computer Society Conference on Computer Vision and Pattern Recognition (CVPR 2009), pages 2372–2379, 2009.
- [3] H.D. Cheng, X.H. Jiang, Y. Sun, and Jingli Wang. Color image segmentation: advances and prospects. Pattern Recognition, 34(12):2259–2281, 2001.
- [4] Neil Rubens, Dain Kaplan, and Masashi Sugiyama. Active learning in recommender systems. In Recommender Systems Handbook, pages 735–767. Springer, 2011.
- [5] Burr Settles. Active learning literature survey. Computer Sciences Technical Report 1648, University of Wisconsin–Madison, 2009.