

Design and Stress-Analysis of a Rigid Flange Coupling using FEM

Saurav Rajgadia¹, Debayan Das², Pawan Jaiswal³, Ankit Basnet⁴, Anupam Raj Jha⁵, Rakesh Jaiswal⁶,
Anush Karki⁷, Rabindra Nath Barman⁸

B.Tech Students, Department of Mechanical Engineering, NIT Durgapur, Durgapur, India ^{1,2,3,4,5,6,7}

Assistant Professor, Department of Mechanical Engineering, NIT Durgapur, Durgapur, India ⁸

ABSTRACT: A Coupling is a device which is responsible for the operative power transmission between two shafts rotating at particular RPM. Coupling is used to connect two different shafts at their end and can slip or fail depending upon the torque limit. It is the crucial part of any power transmission and may last for very long time if designed and maintained properly. The present study of this paper is to reduce the maximum shear stress by selecting a suitable material for flange coupling. For this purpose, modelling of the rigid-flange coupling is carried out in Solidworks and analysed in ANSYS Workbench.

KEYWORDS: Solidworks, ANSYS Workbench, Rigid Flange Coupling, Finite Element Method (FEM).

I. INTRODUCTION

Coupling is a device used to connect the shafts together for the purpose of transmitting power and torque. Generally, couplings are used for connection of shafts unit that are manufactured separately. Such as motor and generator; electric motor and centrifugal pump etc. [1] Due to the inconvenience in transportation of shaft of greater length, it becomes necessary to join two or more shafts by means of coupling. The shafts that are connected by coupling should be easy enough to assemble and dismantle for the purpose of repair and alterations. The severe failure due to shearing of bolts head, key head, nuts and other projecting parts may cause accidents. So, it should be covered by giving suitable shape to the flanges or by providing guards. The shaft to be connected by the coupling may have collinear axes, intercepting axes or a parallel axes with a small distance in between them. [2]

The flange coupling is further classified into two types; Rigid and Flexible Coupling. Rigid flange coupling consists of two separate grey cast iron flanges. One keyed to the driving shaft and the other to the driven shaft by means of nuts and bolts arranged on a circle concentric with the axes of the shafts. [3]

There are two types of rigid flange couplings; Protected and Unprotected rigid flange coupling. In a protected rigid flange coupling, a protective circumferential rim covers the nut and bolt head. So in any case of failure of bolts during operation, broken piece of bolt will dash against this rim and eventually fall down, protecting the operator from any possible injuries. In unprotected rigid flange coupling such protective circumferential rim is absent. So, in any case of failure of bolts, it may hit and harm the operator.

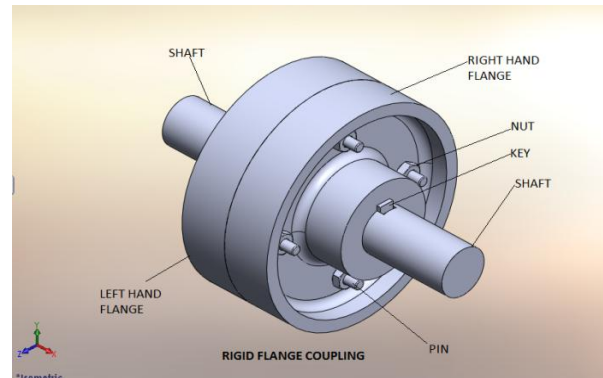

Fig: 1. Isomeric view of protective flange Rigid Coupling

I.I MATERIAL AND ITS PROPERTIES

Rigid flange is usually manufactured by casting as it consists of projection and recess. The commonly used material for flange coupling is grey cast iron which is characterized by graphitic microstructure causing fracture of the material to have a grey appearance. It is one of the most commonly used form of cast iron and the widely used cast material based on casting properties. Most alloys of Iron contain 2.5-4% carbon, 1-3% silicon and the rest is iron by weight proportion. It has less tensile strength and shock resistance as compared to its compressive strength. Its mechanical properties are controlled by the size and morphology of the graphite flakes which deflect a passing crack and initiate counter less new cracks as the material breaks due to which it has good wear resistance and damping capacity. It also experiences less solidification shrinkage than other cast iron that does not form a graphitic microstructure during casting process. The silicon promotes good corrosion resistance and increase fluidity while casting. It also offers good weldability.[4]

Table.1. Material Properties

Items Name	Material
Shaft	Plain Carbon Steel- 40C8
Flange	Grey Cast Iron
Key, Nuts and Bolts	Plain Carbon Steel- 30C8

II. OBJECTIVE

The objective of this paper is to reduce the shear-stress on the nuts and bolts section of a rigid-flange coupling by carrying out the stress-analysis using FEM. The 3-D CAD model was designed in Solidworks 12.0 and the stress-analysis was analysed in ANSYS 14.5 workbench.

III. DESIGN AND CALCULATION

Considering a standard motor with Power = 37.5 kW and RPM = 180
Assuming design torque to be 1.5 times the rated torque

International Journal of Innovative Research in Science, Engineering and Technology

(An ISO 3297: 2007 Certified Organization)

Vol. 4, Issue 10, October 2015

Step I. Selection of materials:

- (i) The shafts are subjected to torsional shear stress. So, on the basis of strength, plain carbon steel of grade 40C8 ($S_{yt} = 380 \text{ N/mm}^2$) is used as shaft material. The factor of safety for the shafts is assumed to be 2.5.
- (ii) The keys and bolts are subjected to shear and compressive stresses. On the basis of stress condition, plain carbon steel of grade 30C8 ($S_{yt} = 400 \text{ N/mm}^2$) is selected for the keys and the bolts. It is assumed that the compressive yield strength is 150% of the tensile yield strength. The factor of safety for the keys and the bolts is also taken as 2.5.
- (iii) Flanges have complex shape and the easiest method of manufacturing is by casting. Grey cast iron FG 200 ($S_{ut} = 200 \text{ N/mm}^2$) is selected as the material for the flanges. It is assumed that ultimate shear strength is one half of the ultimate tensile strength. The factor of safety for the flanges is assumed as 6 (higher than nut and bolts), since to make sure that in case of any failure, bolts get fail first than flanges because flanges are costly and hard to manufacture.

Step II. Permissible stresses:

(i) Shaft

$$\tau = \frac{S_{sy}}{(fs)} = \frac{0.5(380)}{(2.5)} = 76 \text{ N/mm}^2$$

(ii) Keys and bolts

$$\tau = \frac{S_{sy}}{(fs)} = \frac{0.5S_{yt}}{(fs)} = \frac{0.5(400)}{(2.5)} = 80 \text{ N/mm}^2$$

$$\sigma_c = \frac{S_{yc}}{(fs)} = \frac{1.5S_{yt}}{fs} = \frac{1.5(400)}{(2.5)} = 240 \text{ N/mm}^2$$

(iii) Flanges

$$\tau = \frac{S_{su}}{(fs)} = \frac{0.5S_{ut}}{(fs)} = \frac{0.5(200)}{(6)} = 16.67 \text{ N/mm}^2$$

Step III. Diameter of shafts:

Taking into consideration the service factor of 1.5, the design torque is given by,

$$T_d = \frac{60 \times 10^6 (\text{kW})}{2\pi n} \times (1.5)$$

$$= \frac{60 \times 10^6 (37.5)(1.5)}{2\pi(180)}$$

$$= 2984155.18 \text{ N} - \text{mm}$$

$$\tau = \frac{16T_d}{\pi d^3} \text{ or } 76 = \frac{16(2984155.18)}{\pi d^3}$$

\therefore diameter of shaft, $d = 58.48$ or 60 mm

Step IV. Dimensions of flanges:

The torsional shear stress in the hub is given by,

International Journal of Innovative Research in Science, Engineering and Technology

(An ISO 3297: 2007 Certified Organization)

Vol. 4, Issue 10, October 2015

$$\tau = \frac{T_d * r}{J} = \frac{(2984155.18) * (60)}{(19085175.37)} = 9.38 \text{ N/mm}^2$$

$\therefore \tau < [\tau]$ i.e. 16.67 N/mm^2 , where $[\tau]$ is allowable shear stress

The stresses in the flange are within limits.

hub diameter, $d_h = 2d = 2(60) = 120 \text{ mm}$

hub length, $l_h = 1.5d = 1.5(60) = 90 \text{ mm}$

bolt circle diameter, $D = 3d = 3(60) = 180 \text{ mm}$

flange thickness, $t = 0.5d = 0.5(60) = 30 \text{ mm}$

web thickness, $t_1 = 0.25d = 0.25(60) = 15 \text{ mm}$

diameter of spigot and recess, $d_r = 1.5d = 1.5(60) = 90 \text{ mm}$

outside diameter of flange, $D_0 = (4d + 2t_1) = 4(60) + 2(15) = 270 \text{ mm}$

The above dimensions of the flange are shown in Fig.2. The thickness of recess is assumed as 5 mm. The hub is treated as a hollow shaft subjected to torsional moment.

$$J = \frac{\pi(d_h^4 - d^4)}{32} = \frac{\pi(120^4 - 60^4)}{32} = 19085175.37 \text{ mm}^4$$

$$r = \frac{d_h}{2} = \frac{120}{2} = 60 \text{ mm}$$

Step V. Diameter of bolts:

The diameter of the shaft (d) is 60 mm.

$\therefore 40 < d < 100 \text{ mm}$

The number of bolt, $N = 4$.

$$d_1^2 = \frac{8T_d}{\pi DN\tau} = \frac{8(2984155.18)}{\pi(180)(4)(80)}$$

\therefore diameter of bolt, $d_1 = 11.49$ or 12 mm

The compressive stress in the bolt is determined by:

$$\sigma_c = \frac{2M_t}{Nd_1tD} = \frac{2(2984155.18)}{(4)(12)(30)(180)} = 23.03 \text{ N/mm}^2$$

$\therefore \sigma_c < [\sigma_c]$ i.e. 240 N/mm^2 , where $[\sigma_c]$ is allowable compressive stress.

\therefore the design of bolt is safe

Step VI. Dimensions of keys:

From design data book the standard cross-section of the flat key for a 60-mm diameter shaft is $18 \times 11 \text{ mm}$. The length of the key is equal to l_h . Or,

$$l = l_h = 90 \text{ mm}$$

The dimensions of the flat key are $18 \times 11 \times 90 \text{ mm}$.

$$\tau = \frac{2T_d}{dbl} = \frac{2(2984155.18)}{(60)(18)(90)} = 61.4 \text{ N/mm}^2$$

$$\therefore \tau < [\tau] \text{ i.e } 80 \text{ N/mm}^2$$

$$\sigma_c = \frac{4M_t}{dhl} = \frac{4(2984155.18)}{(60)(11)(90)} = 200.95 \text{ N/mm}^2$$

$$\sigma_c < [\sigma_c] \text{ i.e } 240 \text{ N/mm}^2$$

The shear and compressive stresses induced in the key are within permissible limits.

Table 2. Design specification of coupling

Part specification	Dimensions in mm.
Hub diameter (d_h)	120
Hub length (l_h)	90
Bolt circle diameter (D)	180
Flange thickness (t)	30
Web thickness	15
Diameter of spigot and recess (d_r)	90
Outside diameter of flange (D_o)	270

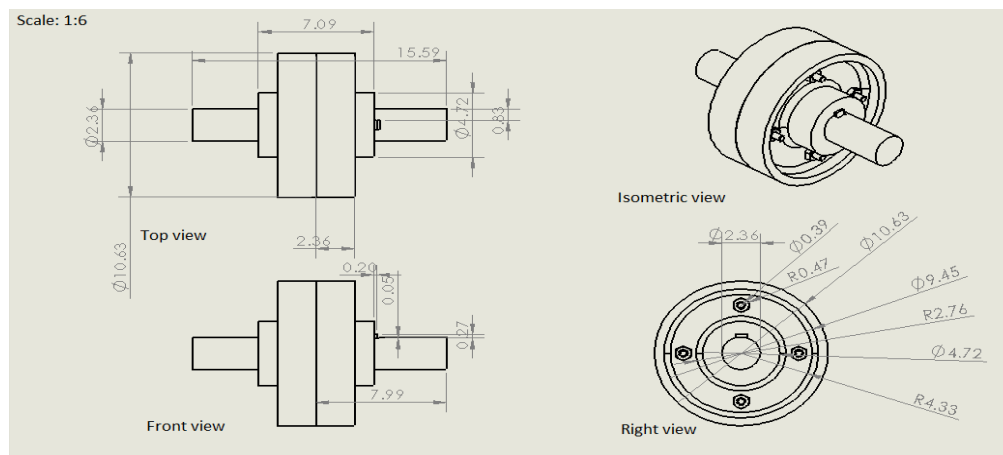

Fig.2. Sketch of Rigid flange Coupling

iv. MESHING

The Figure 3.shown is the meshed model of rigid flange coupling in the ANSYS analysis for the static structural process. To analyse, the FEM triangular type of mesh is used for the rigid flange coupling in the ANSYS environment. The number of elements used in this meshing is 71441and the number of nodes is 122228.In this process regular type of meshing is done to analyse the process. [5]

Using the working condition of the coupling a relative rotational movement between the shafts comes into picture consequently. The determination of the shear stress along the contact region is essential. So, the model is meshed and then analysed to get the detail and authentic result of the stresses of the contact region. [6]

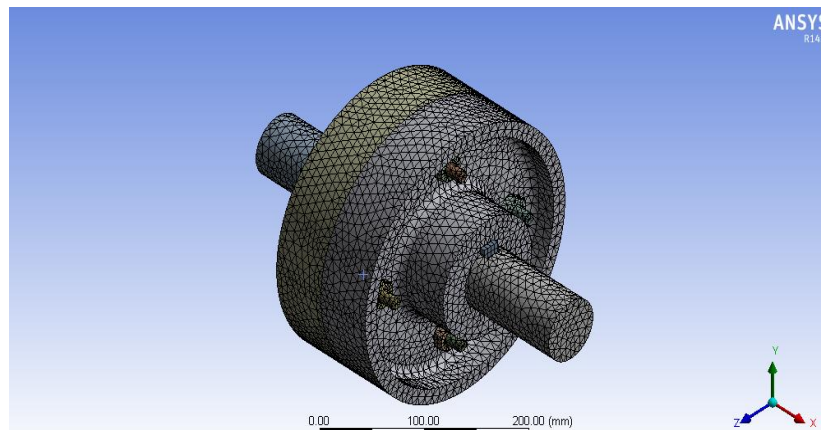

Fig.3. Mesh Model of Rigid Flange Coupling

V. FINITE ELEMENT METHOD (FEM)

The Finite Element Analysis has become the common process of analysis in the recent years. Numerical solution of the complicated problem can be done very easily by using the Finite Element Method. Beside, this the procedure is so important that the industry uses steps of machine design that should be outlined by the principal features. [7]. This method allows the designer to build larger, more improved and complex models resulting, timely, cost effective, accurate and informative solutions to customer problem. [8]The first step of this design is done using the CAD software. The part models are designed using SOLIDWORKS.12 and it is assembled using its different features. In this design we have neglected the bolt-thread and the surface roughness to minimize the complexity. [9]

The material used to manufacture shafts, nuts, bolts, keys and flanges are shown in the table 1. The materials are initially defined as isotropic material with Young's Modulus and Poisson ratio value. [10] The analysis part of the calculation is done using static-structural analysis of ANSYS.14.5 workbench.

VI. ANALYSIS OF RIGID FLANGE COUPLING

According to figure (4-7) shows the result of stress-strain analysis on a rigid flange coupling and the different results obtained with maximum and minimum values of deformation, stress and strain using Finite Element Method (FEM) in ANSYS Workbench.

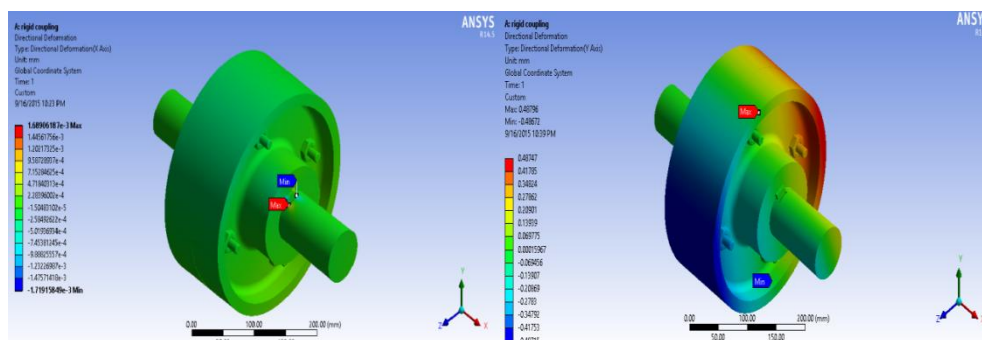

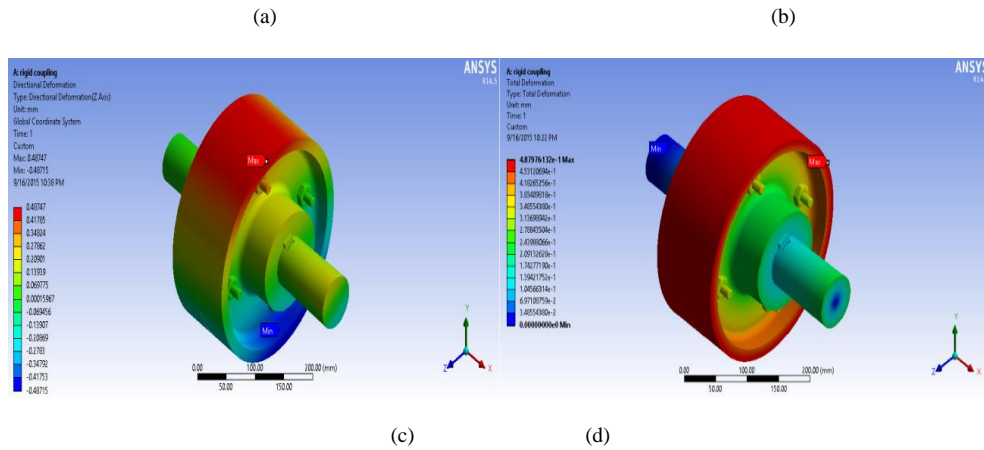
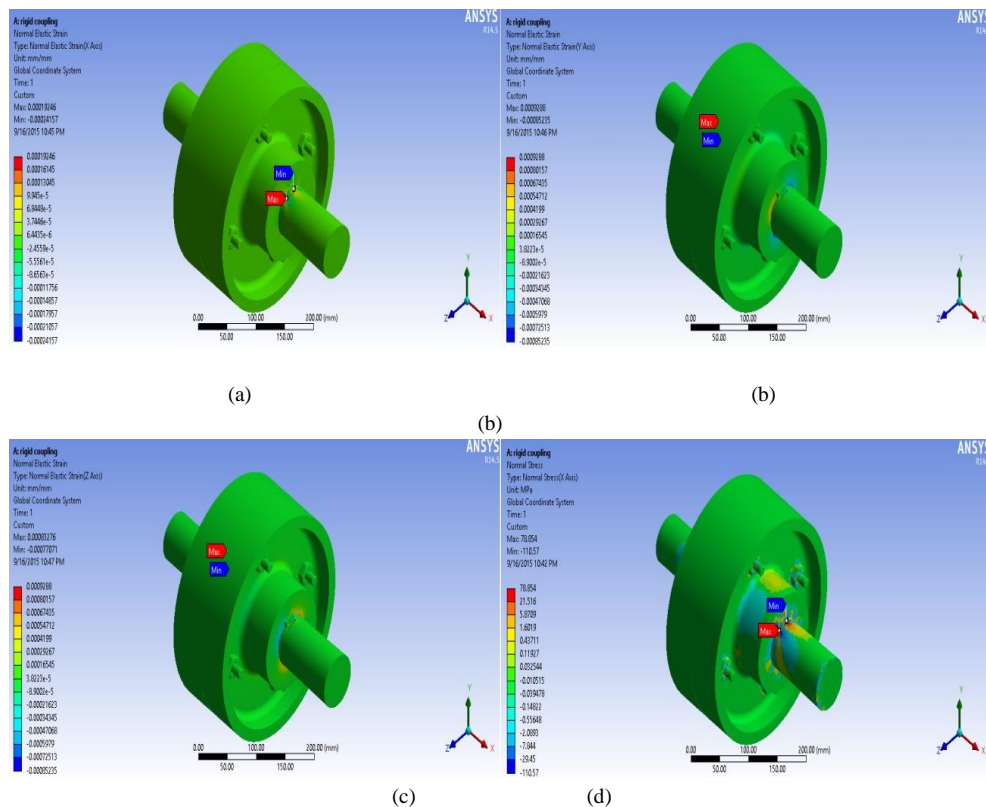

Fig. 4: Directional Deformation (a) Directional deformation along X-axis (b) Directional deformation along Y-axis (c) Directional deformation along Z-axis (d) Total deformation



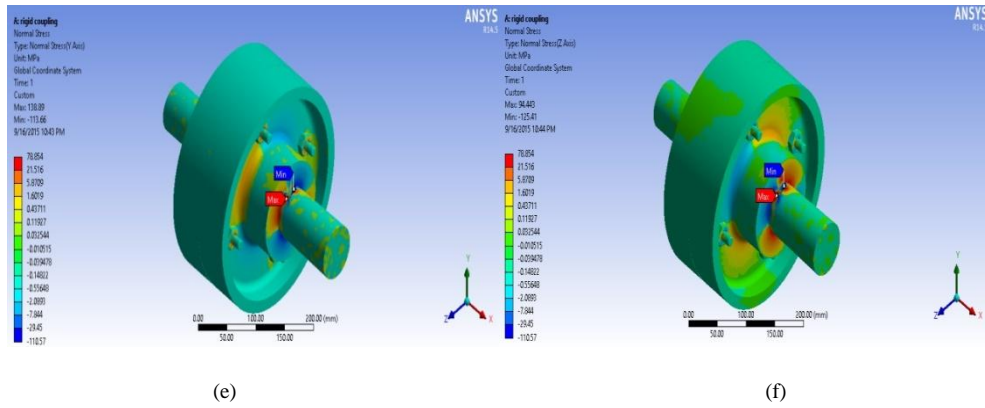
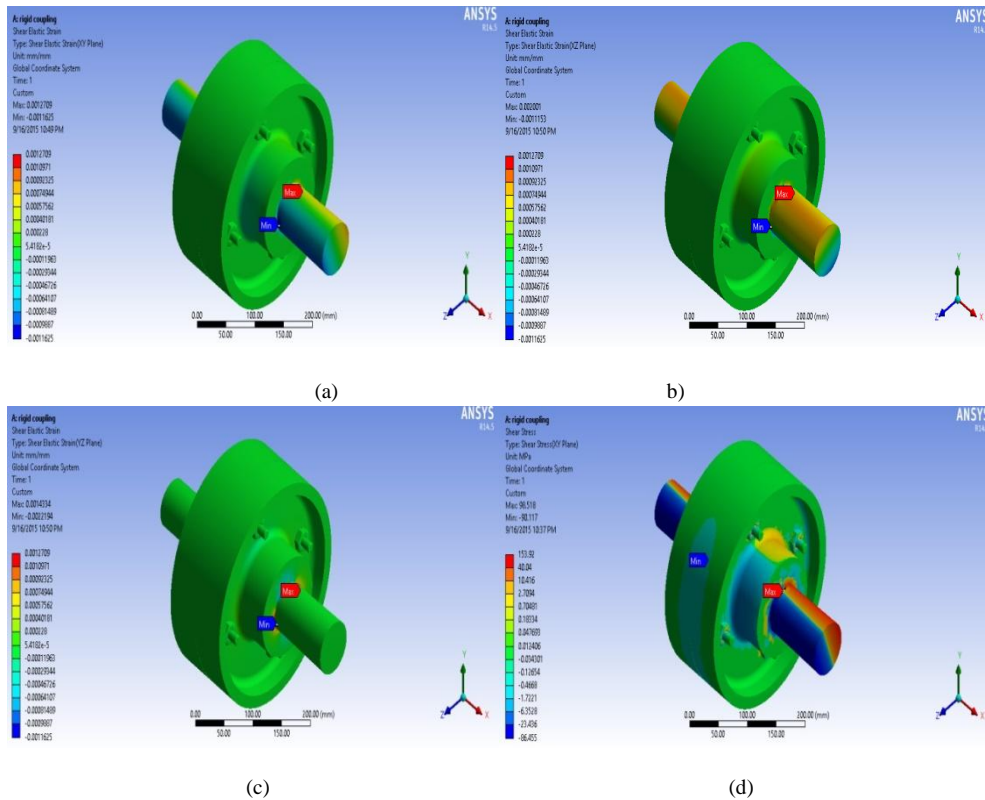

Fig. 5: Normal Stress and strain (a) Normal Elastic Strain along X-axis (b) Normal Elastic Strain along Y-axis (c) Normal Elastic Strain along Z- axis (d) Normal Stress along X- axis (e) Normal Stress along Y- axis (f) Normal Stress along Z- axis



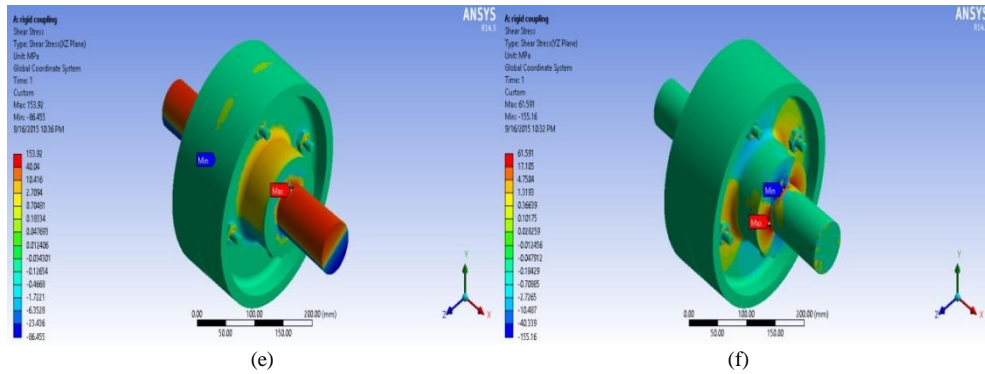

Fig. 6: Shear Elastic strain and stress (a) Shear Elastic Strain along XY plane (b) Shear Elastic Strain along XZ plane (c) Shear Elastic Strain along YZ plane(d) Shear Stress along XY plane (e) Shear Stress along XZ plane (f) Shear Stress along YZ plane

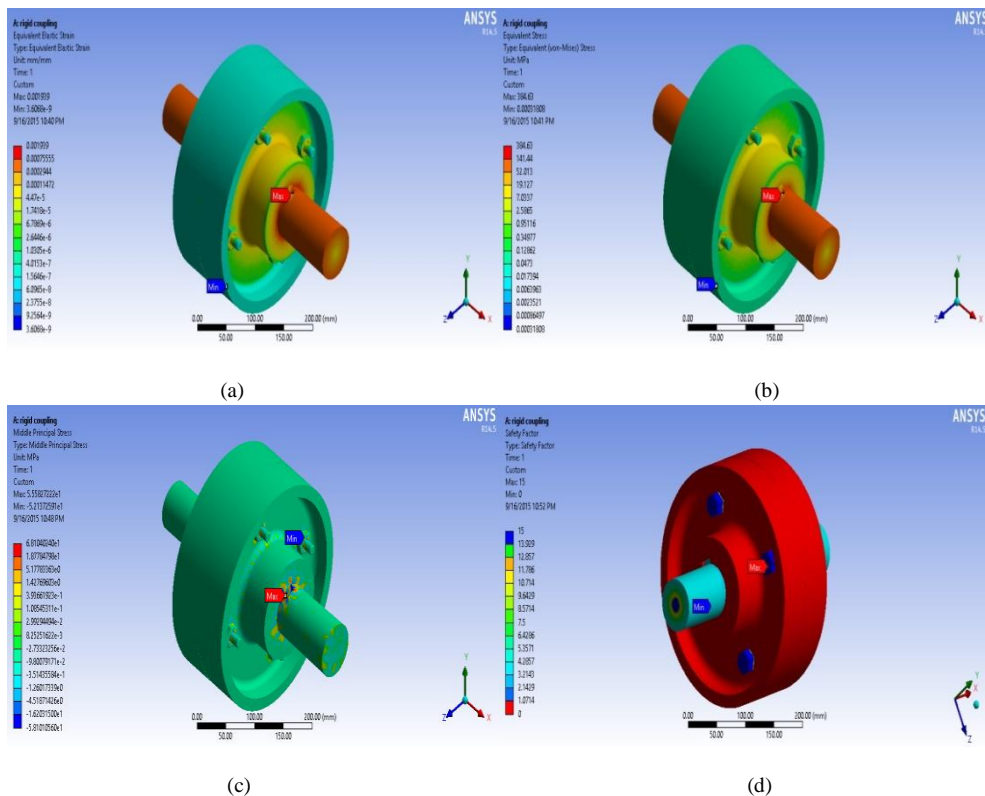

Fig. 7: Equivalent stress and strain (a) Equivalent Elastic Strain (b) Equivalent (Von-Mises) Stress (c) Middle Principle Stress (d) Factor of safety

VII. RESULT

The table below shows the values of stress and strain on a rigid flange coupling under working condition. The result is obtained using ANSYS Workbench. The maximum and minimum values for each parameter has been mentioned below.

International Journal of Innovative Research in Science, Engineering and Technology

(An ISO 3297: 2007 Certified Organization)

Vol. 4, Issue 10, October 2015

Parameters	Maximum	Minimum
Directional Deformation (X- axis) (mm)	1.68906187 e-3	-1.71915849 e-3
Directional Deformation (Y- axis) (mm)	0.48747	-0.48715
Directional Deformation (Z- axis) (mm)	0.48741	-0.48715
Total Deformation (mm)	4.87976132 e-1	0.000
Normal Elastic Strain (X- axis) (mm/mm)	0.0009246	-0.00024157
Normal Elastic Strain (Y- axis) (mm/mm)	0.0009288	-0.0085235
Normal Elastic Strain (Z- axis) (mm/mm)	0.0009288	-0.00085235
Normal Stress (X- axis) (MPa)	78.854	-110.57
Normal Stress (Y- axis) (MPa)	78.854	-110.57
Normal Stress (Z- axis) (MPa)	78.854	-110.57
Shear Elastic Strain (XY plane) (mm/mm)	0.0012709	-0.0011625
Shear Elastic Strain (XZ plane) (mm/mm)	0.0012709	-0.0011625
Shear Elastic Strain (YZ plane) (mm/mm)	0.0012709	-0.0011625
Shear Stress (XY plane) (MPa)	153.92	-86.455
Shear Stress (XZ plane) (MPa)	153.92	-86.455
Shear Stress (YZ plane) (MPa)	61.591	-155.16
Equivalent Elastic Strain (mm/mm)	0.001939	3.6068 e-9
Equivalent (Von- Mises) Stress (MPa)	384.63	0.00031808
Middle Principle Stress (MPa)	6.81040240 e1	-5.81010560 e1
Factor of Safety	15	0

VIII. CONCLUSION

Coupling selection involves a number of design criteria including application, torque (Power), misalignment, stiffness, inertia, rotational speed, environment factors, space limitation, service factor, cost and others. All criteria must be considered and addressed in the selection process to ensure that the coupling will work properly without premature failure. The result obtained from the analysis of the bolts and keys of a rigid-flange coupling using ANSYS workbench

International Journal of Innovative Research in Science, Engineering and Technology

(An ISO 3297: 2007 Certified Organization)

Vol. 4, Issue 10, October 2015

is better than that of calculation using analytical method. From this comparison we can conclude that the design of coupling done using Solidworks is more suitable and safe.

REFERENCES

- [1] Coupling Wikipedia, <https://en.wikipedia.org/wiki/Coupling>
- [2] V.B. Bhandari, Design of Machine Elements, ISBN: 0-07-0681791-1 (978-0-07-068179-8) Design of IC Engine Component, Page no. 356-368
- [3] Rujuta M. Nakhale and G. K. Gattani "Design and Analysis of Coupling using ANSYS". (IJPRET), 2015; Volume 3 (9): 202-206, ISSN: 2319-507X (IJPRET)
- [4] Cast iron: https://en.wikipedia.org/wiki/Cast_iron,
Plain carbon steel: http://saajsteel.com/?page_id=1802
- [5] Praveena S, Lava kumar M and Sreekanth Reddy S "Modeling and Structural Analysis of Disc Brake" (IJIRSET), Vol. 3, Issue 10, October 2014, ISSN: 2319-8753
- [6] A. Belhocine, C.-D. Cho, M. Nouby, Y. B. Yi and A. R. Abu Bakar "Thermal analysis of both ventilated and full disc brake rotors with frictional heat generation" (Applied and computational mechanics 8 (2014) 5-24, Received 3 march 2014; received in revised form 27 June 2014
- [7] Prof. Salunkhe R.T., Mr. Patil N.T., Mr. Lokhande V.S., Mr. Bandelkar D.M. and Mr. Patil R.D. " Design, Modelling, Analysis of Propeller Shaft and Couplings" (IJST), Issue 3 volume 5, Sep.-Oct. 2013, ISSN 2249-9954
- [8] Siraj MohammadAli Sheikh "ANALYSIS OF UNIVERSAL COUPLING UNDER DIFFERENT TORQUE CONDITION" (IJESAT), Volume-2, Issue-3, 690 – 694, ISSN: 2250–3676
- [9] Shivaji G. Chavan "Stress Analysis of Flanged Joint Using Finite Element Method" (IJSR), Volume 3 Issue 8, August 2014, ISSN (Online): 2319-7064
- [10] V. Hariharan and PSS. Srinivasan "Vibration analysis of misaligned shaft ball bearing system" (indjst), Vol.2 No. 9 (Sep 2009), ISSN: 0974-6846
- [11] Shivaji G. Chavan "Stress analysis of flanged joint using finite element method". (IJSR), Volume 3 Issue 8, August 2014, ISSN (Online): 2319-7064
- [12] Kondru Nagendra Babu and Dr. D Sunnel "Failure analysis of flange coupling with two different materials". (IJERT), Vol. 4 Issue 04, April-2015, ISSN: 2278-0181
- [13] V. G. Vijaya "Analysis of rigid flange coupling". (IJIRSET), ISO 3297: 2007, Vol. 2, Issue 12, December 2013, ISSN: 2319-8753
- [14] P.C. Gope, Machine Design Fundamentals and Application, Page 687-694
- [15] V.B. Bhandari, Machine Design Data Book, ISBN: 93-5134-284-0 (978-93-5134-284-7) Chapter 9.6 Coupling