

International Journal of Innovative Research in Science, Engineering and Technology

(An ISO 3297: 2007 Certified Organization)

Vol. 4, Special Issue 13, December 2015

Finite Element Analysis of Friction Stir Welding of Al2024 and 6063aluminium Alloy

A.Rajasekar¹, T.Prabhu²

Assistant Professor, Dept. of Mechanical Engineering, Sasurie College of Engineering, Tirupur, Tamilnadu, India^{1,2}

ABSTRACT: This study aims to model friction stir welding of the aluminum 2024 alloy with 6063aluminum alloy using the finite element method. For this purpose, transient thermal finite element analysis are performed in order to obtain the temperature distribution in the welded joint during the welding operation. Heat input from the tool shoulder and the tool pin are considered as the finite element model. A moving heat source with a heat distribution simulating the heat generated from the friction between the tool shoulder and the work piece is used in the heat transfer analysis. Three-dimensional models are carried out usingHypermesh software.

KEYWORDS: Friction stir welding, finite element analysis, Al2024, Al6063.

I. INTRODUCTION

Friction stir welding (FSW) is an innovative solid state welding process. Friction stir welding represents one of the most significant developments in joining technology in the last half century. Friction stir welding is one such non-melting joining technology that has produced structural joints superior to conventional arc welds in aluminum. Friction stir welding produces higher strength, increase fatigue life, lower distortion, less residual stress, less sensitivity to corrosion and essentially defect free joints compared to arc welding.

Friction stir welding is accomplished with both monolithic and multiple-piece pin tools rotating at several hundred RPM and traversing a square butt joint of the same design configuration used for fusion welding. A plunge load is imparted through a spindle, driven by a FSW machine, and reacted against a backside anvil. Frictional heating under the pin tool and around the pin tip generate sufficient heat to locally plasticize the aluminum alloys to be welded. Tool rotation during the FSW process imparts a material flow in three dimensions to the plasticized weldment, causing complete mixing of the alloys.

The process is most suitable for components, which are flat and long (plates and sheets) but can be adapted for pipes, hollow sections and positional welding. The welds are created by the combined action of frictional heating and mechanical deformation due to a rotating tool. The maximum temperature reached is of the order of 80 % of the melting temperature. The tool has a circular section except at the end where there is a threaded probe or more complicated; the junction between the cylindrical portion and the probe is known as the shoulder. The probe penetrates the work piece whereas the shoulder rubs with the top surface. The heat is generated primarily by friction between rotating translating tools, the shoulder of which rubs against the work piece.

International Journal of Innovative Research in Science, Engineering and Technology

(An ISO 3297: 2007 Certified Organization)

Vol. 4, Special Issue 13, December 2015

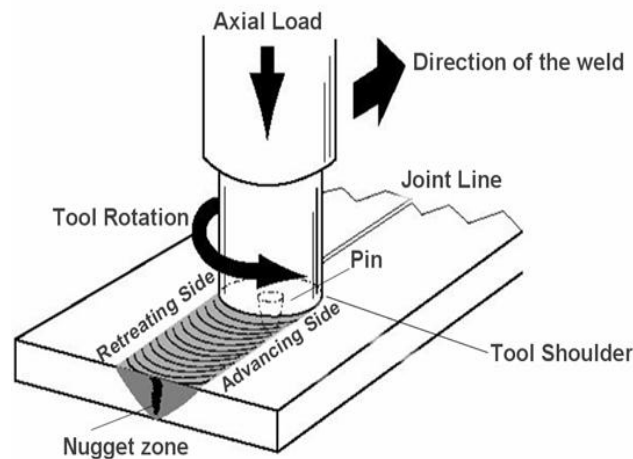

Figure 1.1 Experimental setup

Friction stir welding enjoys a number of advantages over fusion welding processes, including the elimination of welding consumables such as gas, filler metal, and electrodes. As a joining process based on frictional heating due to mechanical work, FSW has only three primary weld variables to control. These are plunge force, rotation speed, and weld travel speed. The solid-state nature of FSW offers other advantages, including improved mechanical properties; elimination of welding fumes, porosity and spatter; low shrinkage; and reduced weld distortion. Furthermore, the process can be performed in a single pass and in all work piece positions. Application of Friction stir welding are Shipbuilding and marine industries, Aerospace industry, Land transportation, other Industry sectors.

II. LITERATURE REVIEW

The literature is based on Friction stir welding of aluminum alloys and copper. C.Genevois et al (2011) carried out Friction stir welding between aluminum 1050 and copper. The tool pin was fully located in the aluminum plate. In this case, there is no mechanical mixing between the two materials. But there was a frictional heating help to the formation of defect-free joints where the weld is obtained by a very thin intermetallic layer at the copper aluminum interface. Two phases were achieved during the welds such as Al₂Cu and Al₄Cu₉. In the nugget zone, there is a slight decrease in hardness that of the original plate. On the Cu side, there were two regions namely the parent material and a hardened region near the interface with steep hardness gradient.

JiahuOuyang et al (2005) concentrated on the temperature distribution and micro structural evolution of the friction stir welding of 6061 aluminum alloy (T6-temper) with copper. The mechanically mixed region in the joining of the dissimilar metals 6061 aluminum alloy and copper weld consists mainly of several intermetallic compounds namely CuAl₂, CuAl, and Cu₉Al₄ together with small amounts of alpha-Al and the saturated solid solution of Al in Cu. An intercalated structure or vertex flow pattern consisting of CuAl₄ and the saturated solid solution of Al in Cu is formed in the Cu-rich regions adjacent to the bottom of the weld by the mechanical integration of aluminum with copper. The calculated peak temperature in the weld zone of the 6061 aluminum side reaches 580°C, which is distinctly higher than the melting points of the Al-Cu eutectic or some of the hypo- and hyper-eutectic alloys. Distinctly different micro-hardness levels from 136 to 760HV0.2 are produced corresponding to various microstructural features in the weld nugget.

III. MODELING

Aluminum 2024 and 6063 aluminium alloy plates, each with a dimension of 150 × 200 × 6 mm are butt welded in the adapted vertical milling machine for FSW when HyperXtrude program is used. In the present thermal analysis, the

International Journal of Innovative Research in Science, Engineering and Technology

(An ISO 3297: 2007 Certified Organization)

Vol. 4, Special Issue 13, December 2015

work piece is meshed using hypermesh software. This element has a three-dimension thermal conduction capability and can be used for a three-dimensional, steady-state or transient thermal analysis. The element is defined by eight nodes with temperature as single degree of freedom at each node and by the orthotropic material properties. An advantage of using this element is that, the element can be replaced by an equivalent structural element for the structural analysis .Results obtained using Friction Stir Welding Module of HyperXtrude software.

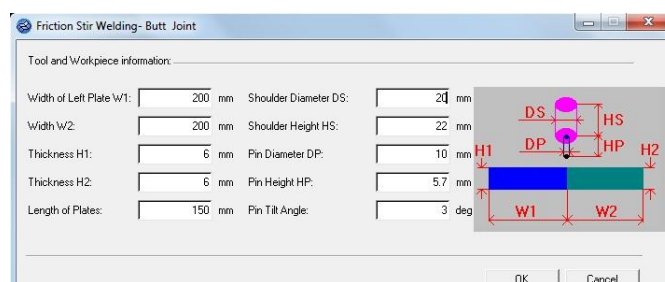

Figure 3.1 Tool and workpiece information

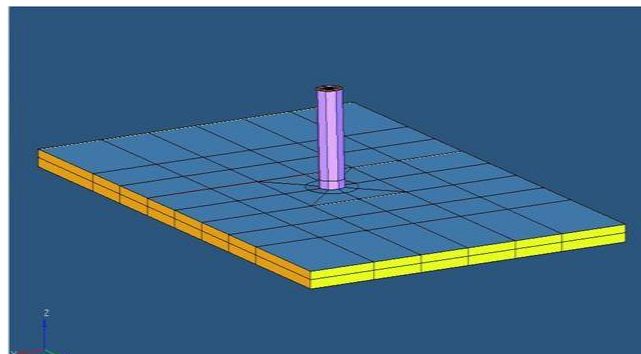

Figure 3.2 Modeling using hypermesh software

IV. RESULT AND DISCUSSION

In the present study, the modeling of friction stir welding is carried out using HyperXtrude commercial software. Transient thermal finite element analyses were performed in order to obtain the temperature distribution in the welded copper and aluminum plates during the welding operation. Figure 4.2 shows the temperature distribution in the work piece during the welding operation.

International Journal of Innovative Research in Science, Engineering and Technology

(An ISO 3297: 2007 Certified Organization)

Vol. 4, Special Issue 13, December 2015

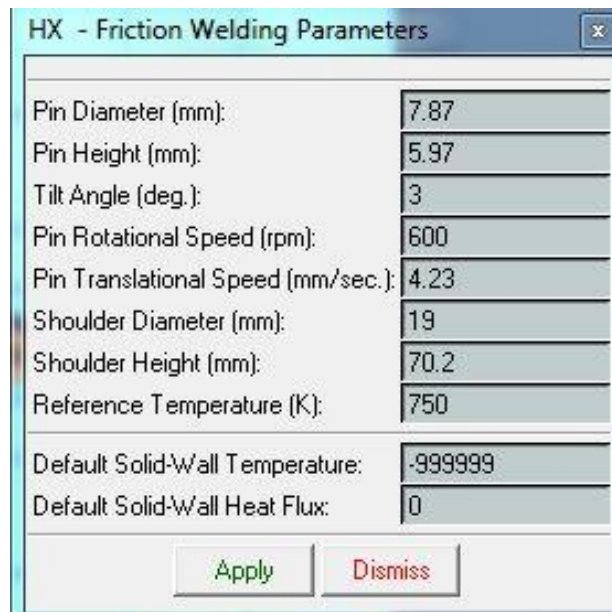

Figure 4.1 Friction welding parameters

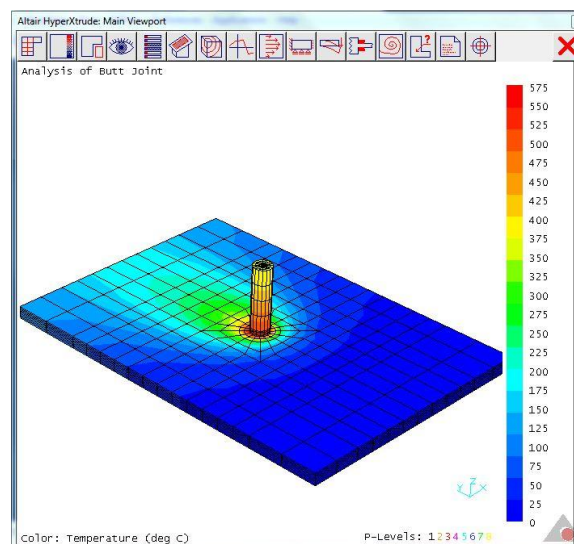

Figure 4.2 Temperature distribution of work piece

The figure 4.2 shows that maximum heat obtained is nearly 550deg C and that was occur in the nugget zone. Based on the rotational speed and feed rate the welding quality is obtained.

International Journal of Innovative Research in Science, Engineering and Technology

(An ISO 3297: 2007 Certified Organization)

Vol. 4, Special Issue 13, December 2015

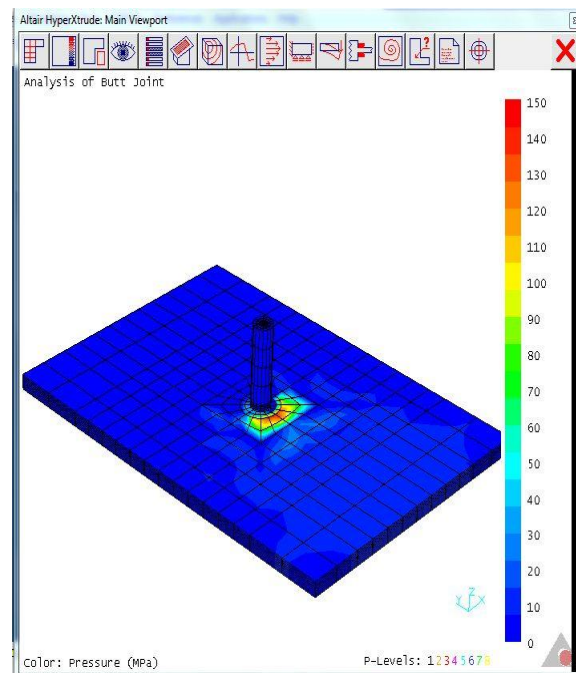

Figure 4.3 Pressure Distribution

From the fig 4.3 the pressure distribution of the tool on the workpiece is shown. It shows that the pressure is only acting on the nugget zone.

As the tool moves along the welding line the effect of preheating ahead of the tool is shown throughout the figure. The maximum temperature reach a value of 556 K at the end of welding process prior to cooling in the stirring zone and this value was in good agreement with that predicted experimentally (760 K). Figure 4.2 shows the temperature time history of a point in the HAZ zone, this figure approve the good agreement of the current study. Peak temperature resulting from transient thermal analysis is more than experimental results because of the lack of accuracy in modeling of heat transfer during FSW process.

IV. CONCLUSION

In the present study, the modeling of friction stir welding is carried out using the transient finite element analyses. A moving heat source with a heat distribution simulating the heat generated from the friction between the tool shoulder and the Finite Element Modeling of work piece is used in the heat transfer analysis. It is observed that the maximum temperature near the weld increases as the tool holding time and rotational speed are increased. Temperature decreases as the tool transverse speed increases. Additionally, it can be concluded that use of a moving heat source technique is proved to be a reliable method to simulate friction stir processing.

REFERENCES

1. Genevois C (2011). 'Interfacial reaction during Friction Stir Welding of Al and Cu', Metallurgical and materials transactions A.
2. Jiahu Ouyang et al., (2005). 'Microstructural evolution in the friction stir welded 6061 aluminum alloy (T6-temper condition) to copper', Elsevier.
3. C.M. Chen, R. Kovacevic, Finite element modeling of friction stir welding-thermal and thermomechanical analysis, International Journal of Machine Tools & Manufacture 43, 1319–1326, 2003.

International Journal of Innovative Research in Science, Engineering and Technology

(An ISO 3297: 2007 Certified Organization)

Vol. 4, Special Issue 13, December 2015

4. Y.J. Chao, X. Qi, W. Tang, Heat transfer in friction stir welding-Experimental and numerical studies, Transactions of the ASME 125, 138-145, 2003.
5. J-Q. Sua, T.W. Nelson, C.J. Sterling. (2005). Microstructure evolution during FSW/FSP of high strength aluminum Alloys. Materials Science and Engineering. A405, 277-286.
6. V. Soundararajan, H. Atharifar and R. Kovacevic, et.al (2002) "Monitoring and processing of acoustic emission signals from friction stir welding process", IMechE Journal of Engineering Manufacture, Feb 2006.
7. Chen H. B., Yan K., Lin T., Chen S. B., Jiang C. Y. and Zhao, et.al Y. (2006) : The investigation of typical welding defects for 5456 aluminum alloy friction stir welds, Materials Science and Engineering, 433A, 64-69.