

International Journal of Innovative Research in Science, Engineering and Technology

(An ISO 3297: 2007 Certified Organization)

Vol. 4, Special Issue 13, December 2015

Advances in Automobile Engineering

K.Loganathan¹, V.V.Mohankumar¹, A.Mahendran², T.Manokaran²

Dept. of Mechanical Engineering, Sasurie College of Engineering, Tirupur, Tamilnadu, India¹

Assistant Professor, Dept. of Mechanical Engineering, Sasurie College of Engineering, Tirupur, Tamilnadu, India²

ABSTRACT:Development in automobile engineering is the sign of rise in civilization. Along with comfort and facilities it has revolutionized the living habits of the people to a great extent. Large scale use of power window, steering system, anti locking brakes, electronic control of car, self inflating tyres etc, will not only reduce the operating cost but also add standards in comfort. Self-inflating tyres are one of them. Tyres are not carrying the weight of cars and trucks but it is the air inside the tyres which carries it. Run flat tyres use a strong side wall material that supports the car even if there is no air in one or more of the tyres. This makes it possible to get where we are going even if a tyre is punctured and deflated. Run flat tyres are constructed using alternating layers of heat resistant cord and rubber and usually crescent –shaped wedges of weight- supporting material, strengthening the sidewalls to prevent them from folding over when there is no air pressure. Self-inflating tyres, on the other hand, are designed to constantly maintain tyre pressure at the proper level. Self-inflating systems are designed more for the slow leaks and for optimizing performance and safety than for keeping a vehicle moving on a tyre that will no longer hold air. Self-inflating tyres allow a vehicle to adjust to the current terrain for ideal performance and safety in those conditions. Currently, lots of consumer vehicles are equipped with pressure-monitoring systems, but there's no way for the driver to do anything about it without an external air source. There are lots of self-inflating-tire systems on the market, but most of them are only available for commercial and military application

I. IGNITION SYSTEM



History Magneto systems

Magneto ignition coil

The simplest form of spark ignition is that using a magnet. The engine spins a magnet inside a coil, or, in the earlier designs, a coil inside a fixed magnet, and also operates a contact breaker, interrupting the current and causing the voltage to be increased sufficiently to jump a small gap. The spark plugs are connected directly from the magneto output. Early magnetos had one coil, with the contact breaker (sparking plug) inside the combustion chamber. In about 1902, Bosch introduced a double-coil magneto, with a fixed sparking plug, and the contact breaker outside the cylinder. Magnetos are not used in modern cars, but because they generate their own electricity they are often found on piston-engine aircraft engines and small engines such as those found in mopeds, lawnmowers, snowblowers, chainsaws, etc. where a battery-based electrical system is not present for any combination of necessity, weight, cost, and reliability reasons.

Aircraft engines usually have multiple magnetos to provide redundancy in the event of a failure. Some older automobiles had both a magneto system and a battery actuated system (see below) running simultaneously to ensure

International Journal of Innovative Research in Science, Engineering and Technology

(An ISO 3297: 2007 Certified Organization)

Vol. 4, Special Issue 13, December 2015

proper ignition under all conditions with the limited performance each system provided at the time. This gave the benefits of easy starting (from the battery system) with reliable sparking at speed (from the magneto).

❖ Switchable systems

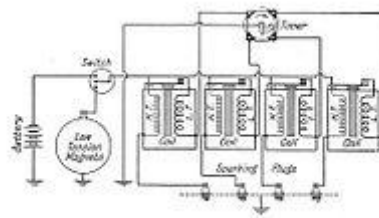

Ford Model T ignition circuit

The output of a magneto depends on the speed of the engine, and therefore starting can be problematic. Some magnetos include an impulse system, which spins the magnet quickly at the proper moment, making easier starting at slow cranking speeds. Some engines, such as aircraft but also the Ford Model T, used a system which relied on non rechargeable dry cells, (similar to a large flashlight battery, and which was not maintained by an electrical system as on modern automobiles) to start the engine or for starting and running at low speed. The operator would manually switch the ignition over to magneto operation for high speed operation.

❖ Battery-operated ignition

With the universal adaptation of electrical starting for automobiles, and the concomitant availability of a large battery to provide a constant source of electricity, magneto systems were abandoned for systems which interrupted current at battery voltage, used an ignition coil (a type of autotransformer) to step the voltage up to the needs of the ignition, and a distributor to route the ensuing pulse to the correct spark plug at the correct time.

The points allow the coil to charge magnetically and then, when they are opened by a cam arrangement, the magnetic field collapses and a large (20 kV or greater) voltage is produced. The capacitor is used to absorb the back EMF from the magnetic field in the coil to minimize point contact burning and maximize point life. The Kettering system became the primary ignition system for many years in the automotive industry due to its lower cost, higher reliability and relative simplicity.^[1]

❖ Modern ignition systems

The ignition system is typically controlled by a key operated Ignition switch.

➤ Mechanically timed ignition



International Journal of Innovative Research in Science, Engineering and Technology

(An ISO 3297: 2007 Certified Organization)

Vol. 4, Special Issue 13, December 2015

Distributor capMostfour-stroke engines have used a mechanically timed electrical ignition system. The heart of the system is the distributor. The distributor contains a rotating cam driven by the engine's drive, a set of breaker points, a condenser, a rotor and a distributor cap. External to the distributor is the ignition coil, the spark plugs and wires linking the distributor to the spark plugs and ignition coil. (see diagram Below)

The system is powered by a lead-acid battery, which is charged by the car's electrical system using a dynamo or alternator. The engine operates contact breaker points, which interrupt the current to an induction coil (known as the ignition coil).

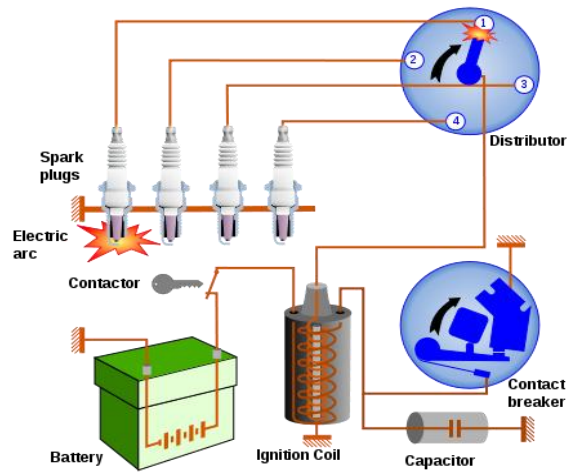

Ignition Circuit Diagram - Mechanically Timed Ignition

❖ Electronic ignition

The disadvantage of the mechanical system is the use of breaker points to interrupt the low-voltage high-current through the primary winding of the coil; the points are subject to mechanical wear where they ride the cam to open and shut, as well as oxidation and burning at the contact surfaces from the constant sparking. They require regular adjustment to compensate for wear, and the opening of the contact breakers, which is responsible for spark timing, is subject to mechanical variations.

In addition, the spark voltage is also dependent on contact effectiveness, and poor sparking can lead to lower engine efficiency. A mechanical contact breaker system cannot control an average ignition current of more than about 3 A while still giving a reasonable service life, and this may limit the power of the spark and ultimate engine speed.

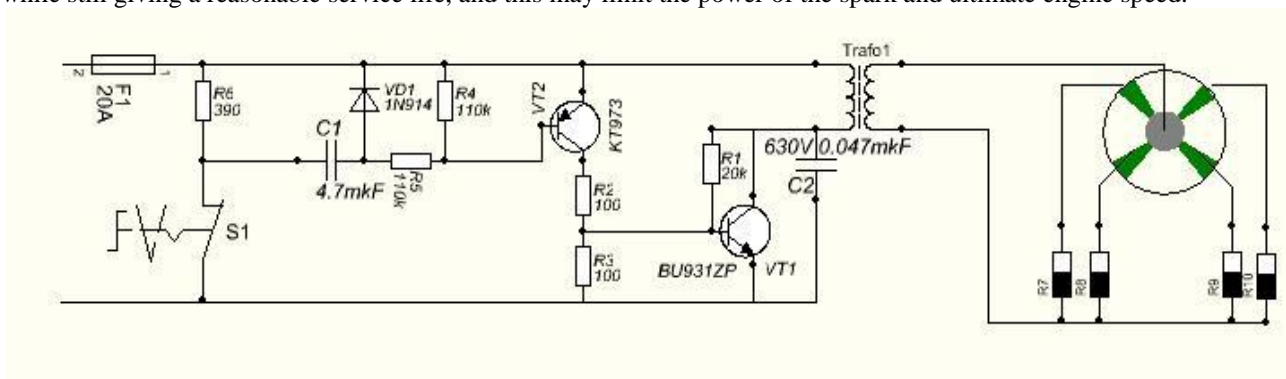

Example of a basic electronic ignition system

International Journal of Innovative Research in Science, Engineering and Technology

(An ISO 3297: 2007 Certified Organization)

Vol. 4, Special Issue 13, December 2015

Electronic ignition (EI) solves these problems. In the initial systems, points were still used but they handled only a low current which was used to control the high primary current through a solid state switching system. Soon, however, even these contact breaker points were replaced by an angular sensor of some kind - either optical, where a vaned rotor breaks a light beam, or more commonly using a Hall effect sensor, which responds to a rotating magnet mounted on the distributor shaft. The sensor output is shaped and processed by suitable circuitry, then used to trigger a switching device such as a thyristor, which switches a large current through the coil.

❖ Digital electronic ignitions

At the turn of the 21st century digital electronic ignition modules became available for small engines on such applications as chainsaws, string trimmers, leaf blowers, and lawn mowers. This was made possible by low cost, high speed, and small footprint microcontrollers. Digital electronic ignition modules can be designed as either capacitor discharge ignition (CDI) or inductive discharge ignition (IDI) systems. Capacitive discharge digital ignitions store charged energy for the spark in a capacitor within the module that can be released to the spark plug at virtually any time throughout the engine cycle via a control signal from the microprocessor. This allows for greater timing flexibility, and engine performance; especially when designed hand-in-hand with the engine carburetor.

❖ Engine management

In an Engine Management System (EMS), electronics control fuel delivery, ignition timing and firing order. Primary sensors on the system are engine angle (crank or Top Dead Center (TDC) position), airflow into the engine and throttle demand position. The circuitry determines which cylinder needs fuel and how much, opens the requisite injector to deliver it, then causes a spark at the right moment to burn it. Early EMS systems used analogue computer circuit designs to accomplish this, but as embedded systems became fast enough to keep up with the changing inputs at high revolutions, digital systems started to appear.

Some designs using EMS retain the original coil, distributor and spark plugs found on cars throughout history. Other systems dispense with the distributor and individual coils mounted directly atop each spark plug. This removes the need for both distributor and high-tension leads, both components with a poor record for long-term reliability.

❖ Turbine and jet engines

Turbine engines have a capacitor discharge ignition system using one or more igniter plugs, which are only used at startup or in case the combustor(s) flame goes out. Rocket engines have particularly demanding ignitions systems- if prompt ignition does not occur the chamber can fill with excess fuel and oxidiser and significant overpressure can occur (a 'hard start'). Rockets often employ pyrotechnic devices that place flames across the face of the injector plate, or, alternatively, self-ignition chemicals.

❖ Three-wheeled car

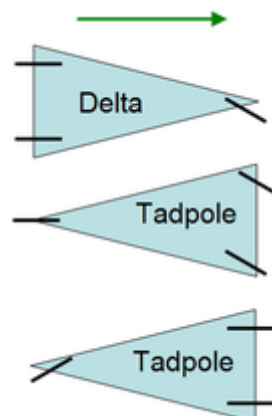

International Journal of Innovative Research in Science, Engineering and Technology

(An ISO 3297: 2007 Certified Organization)

Vol. 4, Special Issue 13, December 2015

A **three wheeled car**, also known as a **tricar** or **tri-car**, is an automobile having either one wheel in the front for steering and two at the rear for power, two in the front for steering and one in the rear for power, or any other combination of layouts. Due to its handling superiority, an increasingly popular form is the front-steering "tadpole" or "reverse trike" sometimes with front drive but usually with rear drive. A variant on the 'one at the front' layout was the Scott Sociable, which resembled a four-wheeler with a front wheel missing^[1]

History

Early car pioneer Karl Benz developed a number of three-wheeled models.^[2] One of these, the Benz Patent Motorwagen,^[3] is widely regarded as the first purpose-built automobile,^[citation needed] and may be the first petrol car driven on British soil, in 1894.^[2] In 1896, John Henry Knight showed a tri-car, recognized as the first British-made motorcar, at The Great Exhibition.^[2] A Conti 6 hp Tri-car competed in (but did not complete) a 1907 Peking-to-Paris race sponsored by a French newspaper, *Le Matin*.^[4]

➤ **Three wheeler configuration**

❖ **Two front**

A configuration of two wheels in the front and one wheel at the back has many strong proponents among automotive designers and enthusiasts. Two advantages are its improved aerodynamics, and that it readily enables small lightweight motorcycle powerplants and rear wheels to be used. This approach was used by Messerschmitt kr200 and by the BMW Isetta. Alternatively, a more conventional front-engine, front wheel drive layout as is common in four-wheeled cars can be used, with subsequent advantages for stability and traction. For the lowest wind resistance (which increases fuel efficiency), a teardrop shape is desirable. A tear drop is wide and round at the front, tapering to a point at the back. The three wheel configuration allows the two front wheels to create the wide round surface of the vehicle. The single rear wheel allows the vehicle to taper at the back. This approach is used by the Aptera 2 Series. It is also used by Myers Motors for both its single passenger NmG and upcoming 2-passenger Duo.

❖ **Two rear**

Having one wheel in front and two in the rear for power reduces the cost of the steering mechanism, but greatly decreases lateral stability when cornering and braking.

❖ **Lateral stability**

The disadvantage of a three wheel configuration is lateral instability - the car will tip over in a turn before it will slide, unless the centre of mass is much closer to the ground or the wheelbase is much wider than a similar four wheel vehicle. Electric three-wheelers often lower the center of gravity by placing the heavy battery pack at the base of the vehicle.

❖ **Tilting option**

To improve stability some three wheelers are designed as tilting three wheelers so that they lean while cornering like a motorcyclist would do. The tilt may be controlled manually or by computer.

➤ **Electronic stability control**

Electronic Stability Control (ESC) is a computerized technology^{[1][2]} that improves safety through a vehicle's stability by detecting and minimizing skids. When ESC detects loss of steering control, it automatically applies the brakes to help "steer" the vehicle where the driver intends to go. Braking is automatically applied to individual wheel, such as the outer front wheel to counter oversteer or the inner rear wheel to counter understeer. Some ESC systems also reduce engine power until control is regained. ESC does not improve a vehicle's cornering performance; instead, it helps to minimize the loss of control. According to IIHS and NHTSA, one-third of fatal accidents could have been prevented by the technology.

BMW, working with Robert Bosch GmbH and Continental Automotive Systems, developed a system to reduce engine torque to prevent loss of control and applied it to the entire BMW model line for 1992. From 1987 to 1992, Mercedes-Benz and Robert Bosch GmbH co-developed a system called Elektronisches Stabilitätsprogramm (Ger. "Electronic Stability Programme" trademarked as ESP) a lateral slippage control system, the electronic stability control (ESC).

International Journal of Innovative Research in Science, Engineering and Technology

(An ISO 3297: 2007 Certified Organization)

Vol. 4, Special Issue 13, December 2015

❖ Operation

During normal driving, ESC works in the background and continuously monitors steering and vehicle direction. It compares the driver's intended direction (determined through the measured steering wheel angle) to the vehicle's actual direction (determined through measured lateral acceleration, vehicle rotation (yaw), and individual road wheel speeds).

❖ Availability and cost

ESC is built on top of an anti-lock brake (ABS) system, and all ESC-equipped vehicles are fitted with traction control. The ESC components include a yaw rate sensor, a lateral acceleration sensor, a steering wheel sensor, and an upgraded integrated control unit. According to National Highway Traffic Safety Administration research, ABS in 2005 cost an estimated US\$368; ESC cost a further US\$111. The retail price of ESC varies; as a stand-alone option it retails for as little as \$250 USD.^[41] However, ESC is rarely offered as a sole option, and is generally not available for aftermarket installation. Instead, it is frequently bundled it with other features or more expensive trims, so the cost of a package that includes ESC could be several thousand dollars. Nonetheless, ESC is considered highly cost-effective^[42] and it might pay for itself in reduced insurance premiums.^[43] When new federal regulations requiring a safety tool called electronic stability control kick in during 2012, all cars will employ it. (cite: <http://redtape.msnbc.com/2010/03/toyota-woes-raise-ghost-in-the-machine-fears.html>)

❖ Future

The market for ESC is growing quickly, especially in European countries such as Sweden, Denmark, and Germany. For example, in 2003 in Sweden the purchase rate on new cars with ESC was 15%. The Swedish road safety administration issued a strong ESC recommendation and in September 2004, 16 months later, the purchase rate was 58%. A stronger ESC recommendation was then given and in December 2004, the purchase rate on new cars had reached 69%^[56] and by 2008 it had grown to 96%. ESC advocates around the world are promoting increased ESC use through legislation and public awareness campaigns and by 2012, most new vehicles should be equipped with ESC.

Just as ESC is founded on the Anti-lock braking system (ABS), ESC is the foundation for new advances such as Roll Stability Control (RSC)^{[14][53]} that works in the vertical plane much like ESC works in the horizontal plane. When RSC detects impending rollover (usually on transport trucks^[50] or SUVs^[57]), RSC applies brakes, reduces throttle, induces understeer, and/or slows down the vehicle.

➤ Suspension (vehicle)



The front suspension components of a Ford Model T.



The rear suspension on a truck: a leaf spring.

International Journal of Innovative Research in Science, Engineering and Technology

(An ISO 3297: 2007 Certified Organization)

Vol. 4, Special Issue 13, December 2015



Part of car front suspension and steering mechanism: tie rod, steering arm, king pin axis (using ball joints).

Suspension is the term given to the system of springs, shock absorbers and linkages that connects a vehicle to its wheels. Suspension systems serve a dual purpose — contributing to the car's roadholding/handling and braking for good active safety and driving pleasure, and keeping vehicle occupants comfortable and reasonably well isolated from road noise, bumps, and vibrations, etc. These goals are generally at odds, so the tuning of suspensions involves finding the right compromise. It is important for the suspension to keep the road wheel in contact with the road surface as much as possible, because all the forces acting on the vehicle do so through the contact patches of the tires. The suspension also protects the vehicle itself and any cargo or luggage from damage and wear. The design of front and rear suspension of a car may be different.

This article is primarily about four-wheeled (or more) vehicle suspension. For information on two-wheeled vehicles' suspensions see the suspension (motorcycle), motorcycle fork, bicycle suspension, and bicycle fork articles.

❖ Important properties



Citroën BX Hydro-pneumatic suspension - maximum to minimum demonstration

❖ Spring rate

The spring rate (or suspension rate) is a component in setting the vehicle's ride height or its location in the suspension stroke. Vehicles which carry heavy loads will often have heavier springs to compensate for the additional weight that would otherwise collapse a vehicle to the bottom of its travel (stroke). Heavier springs are also used in performance applications where the loading conditions experienced are more extreme.

Springs that are too hard or too soft cause the suspension to become ineffective because they fail to properly isolate the vehicle from the road. Vehicles that commonly experience suspension loads heavier than normal have heavy or hard springs with a spring rate close to the upper limit for that vehicle's weight. This allows the vehicle to perform properly under a heavy load when control is limited by the inertia of the load. Riding in an empty truck used for carrying loads can be uncomfortable for passengers because of its high spring rate relative to the weight of the vehicle. A race car would also be described as having heavy springs and would also be uncomfortably bumpy. However, even though we say they both have heavy springs, the actual spring rates for a 2,000 lb (910 kg) race car and a 10,000 lb (4,500 kg) truck are very different. A luxury car, taxi, or passenger bus would be described as having soft springs. Vehicles with worn out or damaged springs ride lower to the ground which reduces the overall amount of compression available to

International Journal of Innovative Research in Science, Engineering and Technology

(An ISO 3297: 2007 Certified Organization)

Vol. 4, Special Issue 13, December 2015

the suspension and increases the amount of body lean. Performance vehicles can sometimes have spring rate requirements other than vehicle weight and load.

❖ Armoured fighting vehicle suspension



II. CONCLUSION

Based on the projected changes in socio-economic factors, energy consumption, and carbon dioxide emissions in the BAU case and the APS case, Working Group members identified seven key findings. These are outlined below:

- ❖ Rapidly increasing demand for energy, particularly fossil fuels, is exerting pressure on regional energy security and the environment.
- ❖ Countries have a range of individual goals such as economic development, poverty alleviation, energy security, greenhouse issues and sustainable development.
- ❖ Advanced energy efficient and low emissions technologies need to be developed, adopted and widely deployed if countries are to simultaneously meet economic and social development and environmental goals.
- ❖ However, there are a variety of country specific barriers to technology development, adoption and widespread deployment.
- ❖ The implementation of currently proposed policies as simulated in the APS case addressed some of these issues. However, it is not sufficient to address the 3E's (economic growth, energy security and environmental protection) to the desired level.

REFERENCES

1. Senthilkumar D, Rajendran I, Giridharadayan M and SelvaSenthilPrabhu C. (2011) 'Fatigue analysis of cryogenic treated en 19 steel using ansys workbench', 2nd International Conference on Simulation Modeling and Analysis - COSMA 2011, Amrita School of Engineering, pp.96-100.
2. Sharma M.C, Nadkarni V.S and GeelaAgnihotri. (1996) 'Corrosion fatigue and fracture behaviour of shot peened carbon steels', International Conference on Shot Peening and blast cleaning, No.7, Dou No.1996028.
3. UrošZupanc and JanezGrum. (2011) 'Surface integrity of shot peened aluminium alloy 7075-T651', Journal of Mechanical Engineering, Vol.57, No.5, pp.379-384.
4. Wencai Liu, Jie Dong, Ping Zhang, ChunquanZhai and Wenjiang Ding. (2009) 'Effect of shot peening on surface characteristics and fatigue properties of T5-treated ZK60 alloy', The Japan Institute of Metals, Vol.50, No.4, pp.791-798.