

# **Fault Detection in Three Phase Induction Motor**

A.Selvanayakam<sup>1</sup>, W.Rajan Babu<sup>2</sup>, S.K.Rajaratna<sup>3</sup>

Final year PG student, Department of Electrical and Electronics Engineering, Sri Eshwar College of Engineering, Coimbatore, Tamilnadu, India<sup>1</sup>

Assistant Professor, Department of Electrical and Electronics Engineering, Sri Eshwar College of Engineering, Coimbatore, Tamilnadu, India<sup>2</sup>

Assistant Professor, Department of Electrical and Electronics Engineering, Sri Eshwar College of Engineering, Coimbatore, Tamilnadu, India<sup>3</sup>

**ABSTRACT:** Induction motor faults can be detected in an initial stage in order to prevent the complete failure of an induction motor and unexpected production costs. Accordingly, this project presents three methods to detect induction motor faults. The first method is a motor fault diagnostic method that identifies the faults like inter-turn short circuits in stator windings, broken rotor bars that helps in identifying the motor fault's severity and air gap eccentricity. These types of faults represent 40 to 50% of all reported faults. In motor fault monitoring method that classifies the operating condition of an induction motor as healthy or faulty.

**KEYWORDS:** Stator winding fault, rotor cage failure, air-gap irregularities.

## **I. INTRODUCTION**

Several alternatives have been used in industry to prevent severe damage to induction motors from the above mentioned faults and to avoid unexpected production shutdowns. Schedule of frequent maintenance is implemented to verify the integrity of the motors, as well as to verify abnormal vibration, lubrication problems, bearings conditions, and stator windings and rotor cage integrity. Most maintenance must be performed with the induction motor turned off, which also implies production shutdown.

Usually, large companies prefer yearly maintenance in which the production is stopped for full maintenance procedures. Redundancy is another way to prevent production shutdowns, but not induction motor failure. Employing redundancy requires two sets of equipment, including induction motors. The first set of equipment operates unless there is a failure, in which case the second set takes over. This solution is not feasible in many industrial applications due to high equipment cost and physical space limitations. Thus, in this thesis an alternative to these approaches is proposed.

Specifically, this thesis addresses electrically detectable faults that occur in the stator windings and rotor cage, namely inter-turn short circuits in stator windings and broken rotor bars. The methods developed in this thesis detect motor faults without the necessity of invasive tests or process shutdowns. Moreover, the presented methods monitor the operating induction motor continuously, so that human inspection is not required to detect motor faults.

## **II. STATOR WINDING FAULT**

Inter-turn short circuits in stator windings constitute a category of faults that is most common in induction motors. Typically, short circuits in stator windings occur between turns of one phase, or between turns of two phases, or between turns of all phases. Moreover, short circuits between winding conductors and the stator core also occur. The different types of winding faults are summarized below as follows

- Inter-turn short circuits between turns of the same phase, winding short circuit, short circuits between winding and stator core, short circuits on the connections, and short circuits between phases are usually caused by stator voltage transients and abrasion.
- Burning of the winding insulation and consequent complete winding short circuits of all phase windings which are usually caused by motor overloads and blocked rotor, as well as stator energization by sub-rated voltage and over rated voltage power supplies. This type of fault can be caused by frequent starts and rotation reversals.
- Inter-turn short circuits are also due to voltage transients that can be caused by the successive reflection resulting from cable connection between motors and ac drives. Complete short circuits of one or more phases can occur because of phase loss, which is caused by an open fuse, contactor or breaker failure, connection failure, or power supply failure.
- Short circuits in one phase are usually due to an unbalanced stator voltage. An unbalanced voltage is caused by an unbalanced load in the power line, bad connection of the motor terminals, or bad connections in the power circuit. Moreover, an unbalanced voltage means that at least one of the three stator voltages is under or over the value of the other phase voltages.

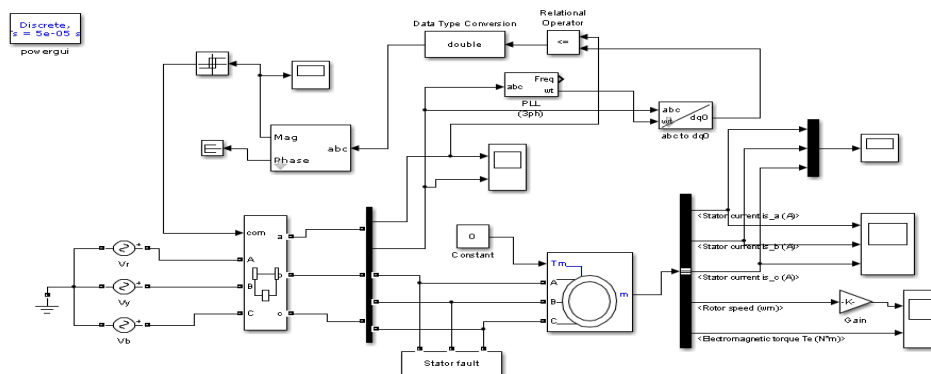

Fig 1. Simulink model of stator winding fault

The above figure 1 shows the Simulink model of stator winding fault works by giving the input supply is given to the stator through the three phase breaker and the voltage and current measurement block. Hence the direct voltage and current components and the components after converting from abc to dq components are compared using the relational operator and the output of it is again converted from abc to dq components to activate the relay function giving it as a feedback to the circuit breaker which trips the supply during the fault condition.

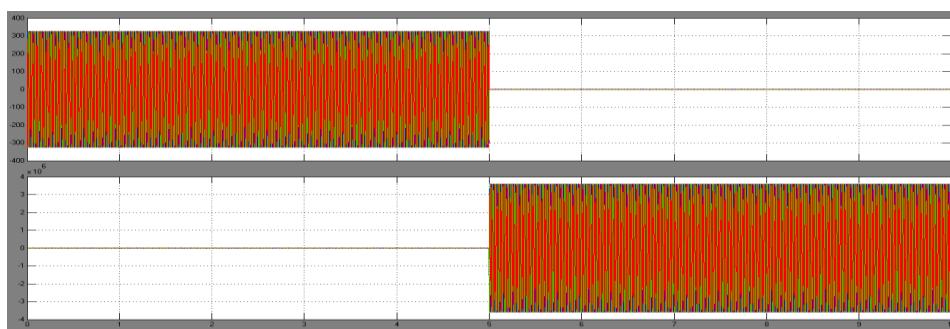

Fig 2 Simulink Output showing the voltage and current waveform

The above figure shows the voltage and current waveform for the Simulink model of figure 1 where the output will be normal till the fault occurs. At the time the fault occurs, the input trips off and the motor stops its operation.

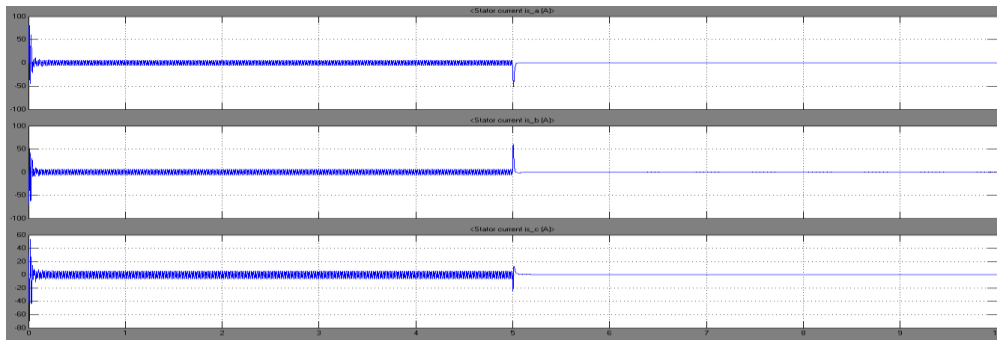

Fig 3. Simulink Output showing the three phase current waveforms

The above figure 3 shows the output waveform for three phase current which shows the normal flow of motor current till the fault occurs, when the fault occurs the motor operation stops.

The above figure 3 shows the output waveform for three phase current which shows the normal flow of motor current till the fault occurs, when the fault occurs the motor operation stops.

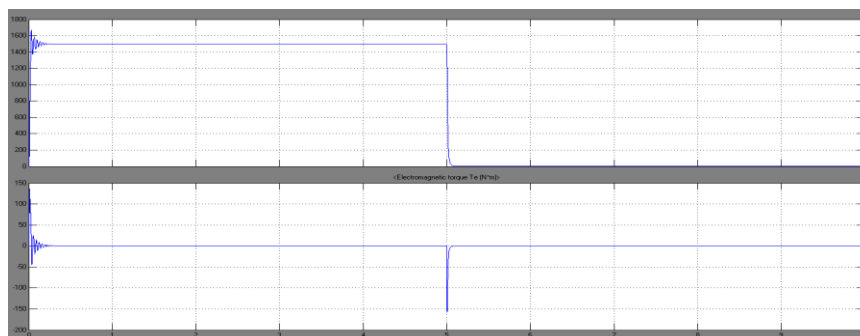

Fig 4. Simulink Output showing the speed and torque waveforms

The above figure 4 shows the speed and torque waveform which is normal and steady after few oscillations and when a fault occurs, the motor operation stops and hence the motor torque and speed comes zero.

### III. ROTOR CAGE FAILURES

The squirrel cage of an induction motor consists of rotor bars and end rings. A broken bar can be partially or completely cracked. Such bars may break because of manufacturing defects, frequent starts at rated voltage, thermal stresses, and/or mechanical stress caused by bearing faults and metal fatigue.

A broken bar causes several effects in induction motors. A well-know effect of a broken bar is the appearance of the so-called sideband components. These sidebands are found in the power spectrum of the stator current on the left and right sides of the fundamental frequency component.

The frequencies of these sideband are given by:

$$fb = (1 \pm 2s) f, \quad (3.26)$$

where s is the slip in per unit and f is the fundamental frequency of the stator current.

Other electric effects of broken bars are used for motor fault classification purposes including speed oscillations, torque ripples, instantaneous stator power oscillations, and stator current envelopes. Here the fault monitoring method is based on torque ripples for broken bar detection, while the fault diagnostic method is based on the three-phase stator current envelope for classification of broken rotor bars and inter-turn short circuits.

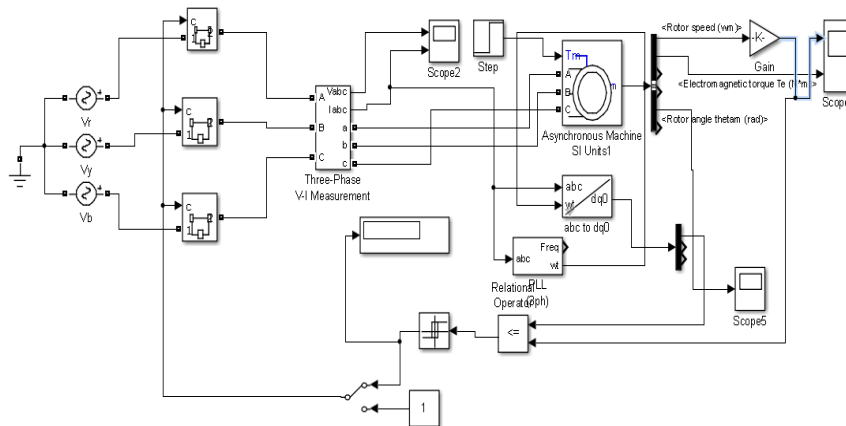

Fig 5. Simulink model of rotor cage failure

The above figure 5 shows the Simulink model of rotor cage failure where the relay is connected to the circuit breaker. If fault occurs in rotor the changes of motor operation from normal operating condition then the relay trips the circuit breaker so that the motor becomes to rest.

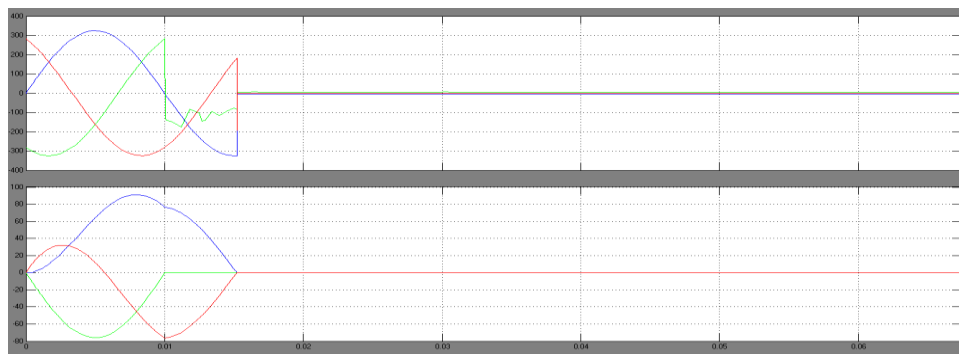

Fig 6. Simulink Output showing the voltage and current waveforms

The above figure 6 shows the output voltage and current waveform for the rotor cage failure, where the three phase voltages and currents will flow normally till the fault condition occurs. When the fault occurs, the motor stops and the voltage and current flow reduce to zero.

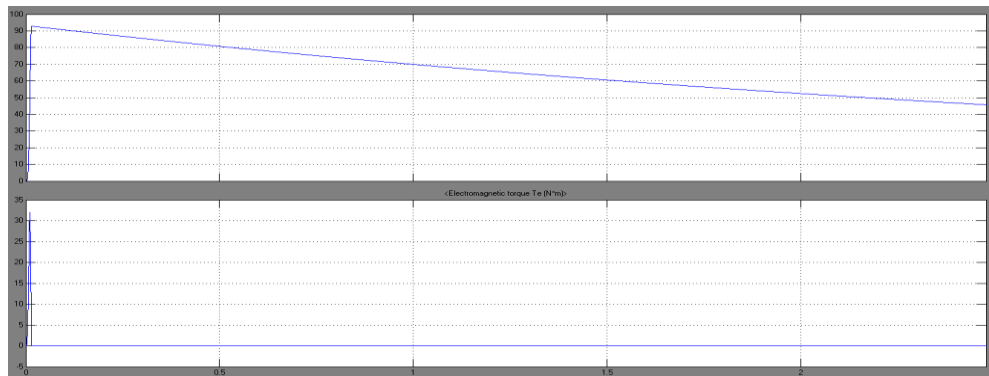

Fig 7. Simulink Output showing the Speed and torque response of induction motor

The above figure 7 shows the speed and torque curve for the rotor cage failure where it runs in its normal speed and torque till the rotor cage failure fault occurs. The value of the speed reduces from its normal value and the torque value reduce to zero at the time of fault.

#### IV. AIR GAP IRREGULARITIES

The air gap torque profile for the same case-study induction motor under the same operating conditions. It is important to observe the same envelope characteristic in both signals, i.e. the frequency of the envelope and the oscillations of air gap torque are the same. The amplitude of the envelope and of the air gap torque is proportional to the motor load. If the motor is loaded, the amplitude of the envelope and of the air gap torque increases. Thus, the profile modulations of the envelope and torque are more evident. For the no load case, the amplitude of the envelope and the torque oscillations are very low.

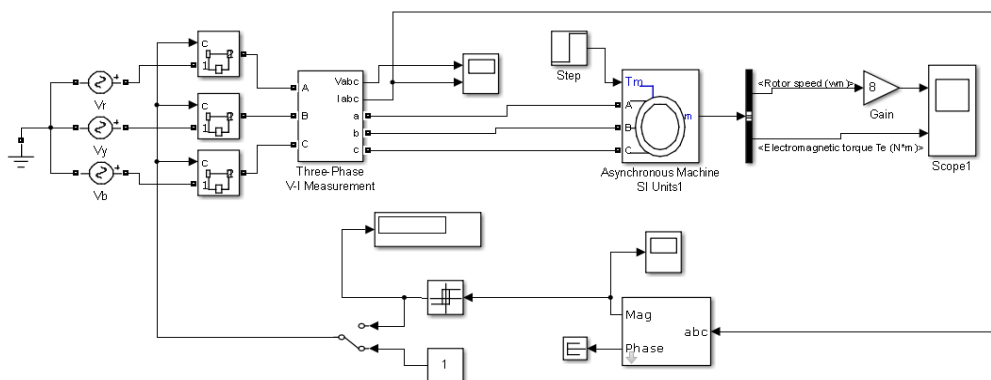

Fig 8. Simulink model of air gap irregularities

The above figure 8 shows the Simulink model of air gap irregularities. Here when the friction factor in the motor parameter block is increased, the air gap between the stator and the rotor reduces.

Here the three phase voltage and current values are changed from abc components to dq components in which the d component specifies the magnitude and q component specifies the phasor value. If the magnitude value is more, then it represents the fault condition.

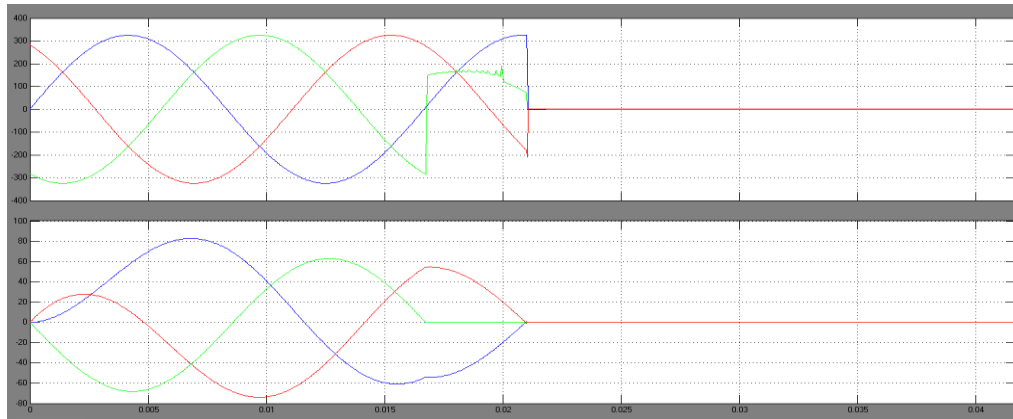

Fig 9. Simulink Output showing the voltage and current waveforms of motor

The above figure 9 shows the voltage and current waveforms for the air gap irregularities. The motor operates in normal condition, once there is a change in airgap due to friction or heavy load then the value of voltage and current becomes to zero.

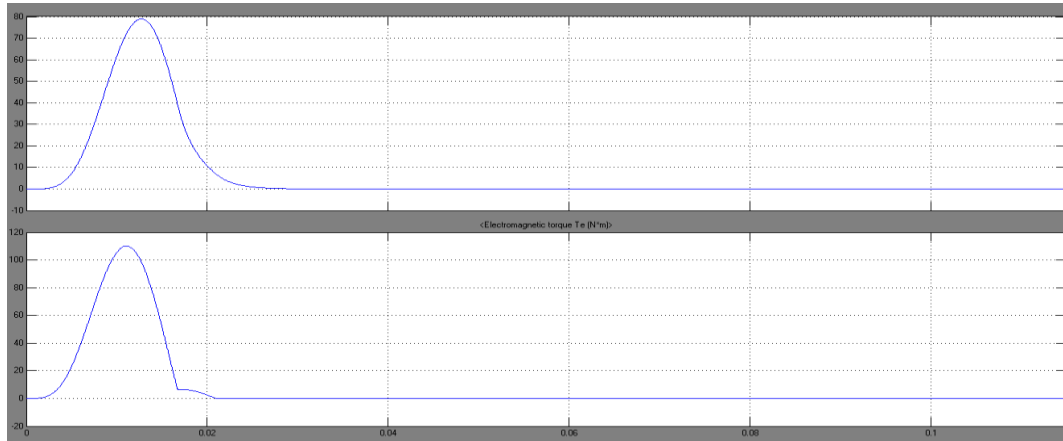

Fig 10. Simulink Output showing the Speed and torque response of induction motor

The above figure 10 shows the speed and torque response of the motor during the air gap irregularities fault condition. In case of drop in voltage and current automatically the speed and torque gets to zero. Then the motor comes to rest.

## V. CONCLUSION

In this work, the basic concepts about induction motors and ac drives, as well as the various types of induction motor faults, namely inter-turn short circuits in stator windings, broken rotor bar and the air gap irregularities has been presented. Moreover, the physical phenomenon associated with each of these faults was described, and the features of the induction motor performance resulting from these faults was presented using the simulink model for each these faults.

## REFERENCES

- [1] M. da Silva, R. J. Povinelli, and N. A. O. Demerdash, "Induction Machine Broken Bar and Stator Short-Circuit Fault Diagnostics Based on Three Phase Stator Current Envelopes," IEEE Transactions on Industrial Electronics, 2006.
- [2] N. M. Elkasabgy, A. R. Eastham, and G. E. Dawson, "Detection of broken bars in the cage rotor on an induction machine," IEEE Transactions on Industry Applications, vol. 28, pp. 165-171, 1992.
- [3] J. S. Hsu, H. H. Woodson, and W. F. Weldon, "Possible errors in measurement of air-gap torque pulsations of induction motors," IEEE Transactions on Energy Conversion, vol. 7, pp. 202-208, 1992.
- [4] M. Haji, S. Ahmed, and H. A. Toliyat, "Induction machines performance evaluator 'torque speed estimation and rotor fault diagnostic'," in Proceedings of the Seventeenth Annual IEEE Applied Power Electronics Conference, vol. 2, pp. 764-769, 2002.
- [5] V. V. Thomas, K. Vasudevan, and V. J. Kumar, "Implementation of online air-gap torque monitor for detection of squirrel cage rotor faults using TMS320C31," in Proceedings of the International Conference on Power Electronics, Machines and Drives, pp. 128-132, 2002.
- [6] I.C. Report, "Report of large motor reliability survey of industrial and commercial installation, Part I and Part II," IEEE Transactions on Industry Applications, vol. 21, pp. 853-872, 1985.
- [7] S. Nandi, H. A. Toliyat, and X. Li, "Condition Monitoring and Fault Diagnosis of Electrical Motors - A Review," IEEE Transactions on Energy Conversion, vol. 20, pp. 719-729, 2005.
- [8] J. Penman, H. G. Sedding, B. A. Lloyd, and W. T. Fink, "Detection and location of interturn short circuits in the stator windings of operating motors," IEEE Transactions on Energy Conversion, vol. 9, pp. 652-658, 1994.
- [9] B. Mirafzal and N. A. O. Demerdash, "Induction machine broken-bar fault diagnosis using the rotor magnetic field space-vector orientation," IEEE Transactions on Industry Applications, vol. 40, pp. 534-542, 2004.
- [10] M. E. H. Benbouzid, "Bibliography on induction motors faults detection and diagnosis," IEEE Transactions on Energy Conversion, vol. 14, pp. 1065-1074, 1999.
- [11] A. Bellini, F. Filippetti, G. Franceschini, C. Tassoni, and G. B. Kliman, "Quantitative evaluation of induction motor broken bars by means of electrical signature analysis," IEEE Transactions on Industry Applications, vol. 37, pp. 1248-1255, 2001.
- [12] M. E. H. Benbouzid, "A review of induction motors signature analysis as a medium for faults detection," IEEE Transactions on Industrial Electronics, vol. 47, pp. 984-993, 2000.
- [13] S. M. A. Cruz and A. J. M. Cardoso, "Rotor cage fault diagnosis in three-phase induction motors by the total instantaneous power spectral analysis," in Proceedings of the IEEE Industry Applications Conference. Thirty-Fourth IAS Annual Meeting, vol. 3, pp. 1929-1934 vol.3, 1999.
- [14] S. Fruchtenicht, E. Pittius, and H. O. Seinsch, "A diagnostic system for three-phase asynchronous machines," in Proceedings of the Fourth International Conference on Electrical Machines, pp. 163-171, 1989.
- [15] J. S. Hsu, "Monitoring of defects in induction motors through air-gap torque observation," IEEE Transactions on Industry Applications, vol. 31, pp. 1016-1021, 1995.
- [16] J. L. Kohler, J. Sottile, and F. C. Trutt, "Alternatives for assessing the electrical integrity of induction motors," IEEE Transactions on Industry Applications, vol. 28, pp. 1109-1117, 1992.
- [17] B. Mirafzal and A. O. Demerdash, "On Innovative Methods of Induction Motor Interturn and Broken-Bar Fault Diagnostics," IEEE Transactions of Industry Applications, pp. 405-414, 2005.