

Single Phase Switched-Capacitor/ Switched-Inductor Quasi-Z-Source Inverter

Nishamol P.T¹, Jassia M.A²P.G. Student, Department of EEE, KMEA Engineering College, Edathala, Kerala, India¹Assistant Professor, Department of EEE, KMEA Engineering College, Edathala, Kerala, India²

ABSTRACT: This paper presents a Single Phase Switched-Capacitor/Switched-Inductor Quasi- Z- Source Inverter (SC/SL qZSI). The SC/SL qZSI topology is based on conventional quasi- Z- source inverter topology. Compared to other traditional topologies based on quasi- Z-source the SC/SL qZSI topology provides higher boost ability, reduced voltage stress. It uses lesser number of passive components and the topology is also expandable. To facilitate understanding of the boosting capability simulation results of the SC/SL quasi-Z-source inverter is compared with the switched capacitor quasi-Z-source inverter (SC qZSI). The proposed topology is applicable to fuel cell, Photovoltaic (PV) and motor drive applications.

KEYWORDS: Switched capacitor/switched inductor (SC/SL), quasi-Z-source (qZSI), boost ability, photovoltaic (PV), Z-source inverter (ZSI)

I. INTRODUCTION

Inverters are devices used to convert dc-ac. It can be of voltage source inverters (VSI) and current source inverters (CSI) among them voltage source inverters are commonly used. In conventional voltage source inverters ac output voltage is always less than dc input voltage, it produces buck voltage at the output side. To boost up output voltage, an additional dc-dc boost converter is required in between the input and output side. In practice ac output voltage is desirable to be higher than dc input. Furthermore an unbalanced midpoint voltage problem is also present in the conventional inverters which leads large ripples at the output side, and makes the system unstable. To solve the limited voltage problem we can add a dc-dc boost converter or a step up transformer in the circuit as explained in [8]. Adding a boost converter in the circuit will increase the cost and volume of the circuit. If a step up transformer is used in the circuit the output voltage will be fixed due to the fixed turns ratio of the transformer.

To overcome the drawbacks of the conventional voltage source inverters Z source inverters are introduced by F. Z. Peng [2]. In a Z source inverter a X-shaped LC network is connected in between the input and output side. Thus the dc source is coupled with the impedance network hence it is termed as Z-source inverter. Z-source inverter can work in shoot through and non shoot through mode. It can overcome the drawbacks of conventional VSI, such as limited voltage and shoot through problem. It can also achieve power conversion in a single stage thus the cost and size of the system will be reduced. The quasi-Z-source inverters are the modified form of Z-source inverters.

The quasi Z-source inverters have some advantages over ZSI [7] and have no disadvantage when compared with the ZSI topology. During shoot through mode large current flows through the switching devices which increases the voltage stress across the switches in the main circuit. In qZSI voltage stress across the switches will be reduced and they offer higher boost ability. The single phase SC/SL qZSI offers a low number of passive components such as capacitors and inductors in the impedance network, higher boost ability and voltage stress across the switches are reduced and the topology is also expandable [1].

II. RELATED WORK

The quasi-Z-source inverters are used in applications where high voltage gain required to obtain desired output voltage from low voltage energy sources, such as PV arrays, fuel cell stacks and batteries. PV arrays will produce low output voltage but in practical applications we require higher ac output voltage. This cannot be realised with conventional voltage source or Z-source inverters. A class of quasi-Z-source inverters are proposed by F. Z Peng [13]. These inverters are similar to the Z-source inverters but have many advantages including reduced component count, reduced source stress and simplified control strategies. The SC/SL structure explained in [5] is transformer less hybrid DC-DC PWM converters. A few simple switching structures formed by either two capacitors and two- three diodes or two inductors and two three diodes are introduced. These structures can be of step up or step down. These blocks are inserted in classical buck, boost, sepic converters. These circuit blocks can provide either a step-down of the input voltage or a step-up of it. The converter presents similar complexity with available converters.

M. Zhu proposed a new SL/ZSI [7] topology which is based on the traditional qZSI topology and adds only one inductor and three diodes to the traditional one. In comparison to the SL-ZSI, for the same input and output voltages the SL-qZSI provides continuous input current, reduced passive component count, reduced voltage stress on capacitors, lower shoot through current and lower current stress on passive components. The SL structure can be applied to both Z-source and quasi – ZSI topologies. However their boosting capabilities are somehow compromised by poor spectral performances caused by low modulation index. To overcome the above drawbacks the SL/SC Z-source inverters are proposed in [9].

This paper presents a single phase SC/SL quasi-Z-source inverter. To increase the boost factor, one cell comprising two inductors and three diodes are connected in series with the dc source. It can be extended to have a very high boost ability by cascading additional cells. The single phase SC/SL qZSI offers a low number of passive components in the impedance network.

III. SINGLE PHASE SC/SL QUASI-Z- SOURCE INVERTER

The single phase SC/SL quasi-Z-source inverter topology is based on conventional quasi-Z-source inverter topology. By adding impedance network which constitutes three diodes and two inductors the boosting ability of the inverter can be increased. Fig.1 shows the schematic of single phase SL/SC qZSI in which an impedance network comprising one active switch (S_5), inductors (L_1, L_2), capacitor (C), diodes (D_1, D_2, D_3, D_i , & D_b) couples the inverter bridge to the dc voltage source. It has two operating states, shoot through and non shoot through state.

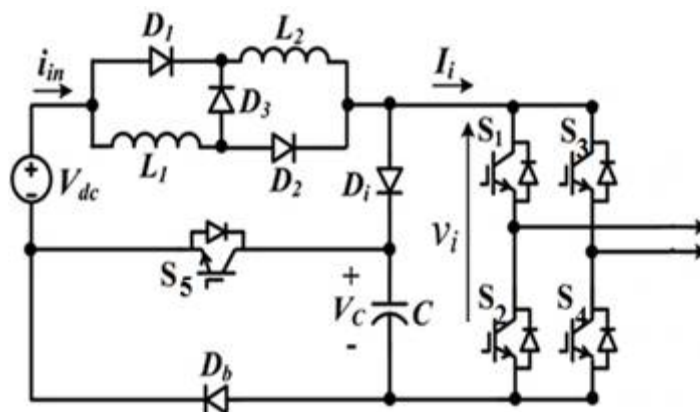

Fig. 1 Single phase SC/SL qZSI

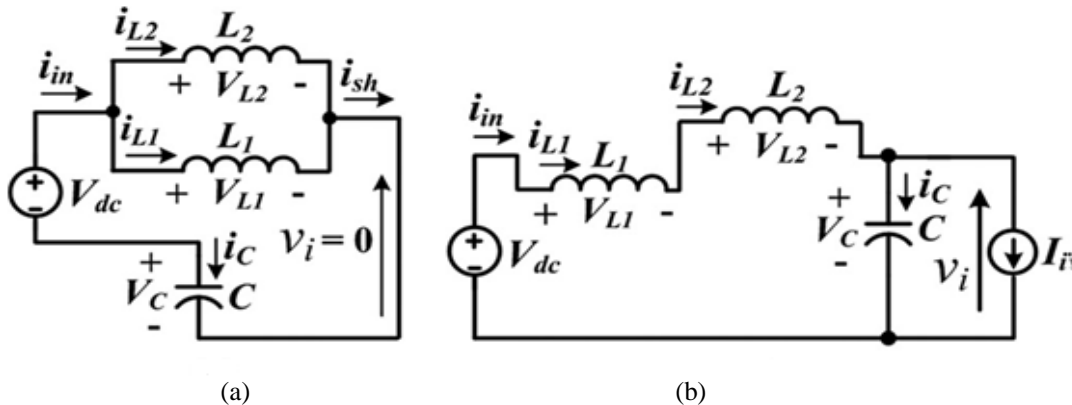

Fig.2 Equivalent circuits of SC/SL qZSI (a) shoot through state and (b) non-shoot through state

Fig. 2(a) and 2(b) shows the equivalent circuits of SC/SL qZSI during shoot through and non- shoot through state. In shoot through state the upper and lower switching devices of any phase leg conducts simultaneously thus the load terminal is shorted and the switching device S_5 is turned on during this state, and the diodes D_1, D_2 are ON, whereas the diodes D_a, D_b and D_3 are OFF. The inductors L_1 and L_2 are connected in parallel. The inductors stores energy during shoot through state from both dc input source V_{dc} and capacitor C through S_7 and the inverter bridge. Therefore capacitor C is discharged.

From Fig. 2(a) we have

$$V_{L1(ST)} = V_{L2(ST)} = V_{dc} + V_C \tag{1}$$

$$i_c = -(i_{L1} + i_{L2}) \tag{2}$$

$$v_i = 0 \tag{3}$$

In the non shoot through state inverter delivers stored energy to the load, in this state the switch S_7 turns OFF. The inductors L_1 and L_2 connected in series. The diodes D_1, D_2 are OFF and the diodes D_a, D_b and D_3 are ON. The dc input and two inductors transfer energy to both the inverter and capacitor through the diodes D_3, D_a, D_b . Thus the capacitor C is charged.

From Fig. 2(b)

$$V_{L1(INST)} = V_{dc} - V_C - V_{L2(INST)} \tag{4}$$

$$V_{L2(INST)} = V_{dc} - V_C - V_{L1(INST)} \tag{5}$$

$$i_c = i_{L1} - I_i = i_{L2} - I_i \tag{6}$$

$$v_i = V_C \tag{7}$$

The voltage across L_1 during non shoot through state from equation (1) and (5)

International Journal of Innovative Research in Science, Engineering and Technology

(An ISO 3297: 2007 Certified Organization)

Vol. 5, Issue 8, August 2016

$$V_{L1(INST)} = \frac{1}{1-D_{sh}} V_{dc} + \frac{2D_{sh}-1}{1-D_{sh}} V_{dc} \tag{8}$$

From equation (1) and (8) the voltage across the capacitor is

$$V_C = \frac{1+D_{sh}}{1-3D_{sh}} V_{dc} \tag{9}$$

Using equation (9) boost factor of the SL/SC quasi ZSI can be expressed as

$$B = \frac{V_i}{V_{dc}} = \frac{V_C}{V_{dc}} = \frac{1+D_{sh}}{1-3D_{sh}} \tag{10}$$

IV. MAXIMUM CONSTANT BOOST CONTROL METHOD

There are various methods used to control quasi- Z-source inverter. Pulse width modulation technique is used for the proposed topology. Three types of pulse width modulation techniques are there, which are simple boost control, maximum boost control and maximum constant boost control. The shoot through state can be controlled by using suitable PWM method. Fig.3 shows the maximum constant boost control strategy. The shoot through state controlled by two shoot through envelope signals V_p and V_n is kept constant. Whenever the high frequency carrier waveform greater than the upper shoot through envelope V_p or lower than lower shoot through envelope V_n , the inverter operates in shoot through state. Otherwise it operates in non-shoot through mode. In non- shoot through mode it works like a traditional PWM inverter. The switching device S_5 turns on during this state.

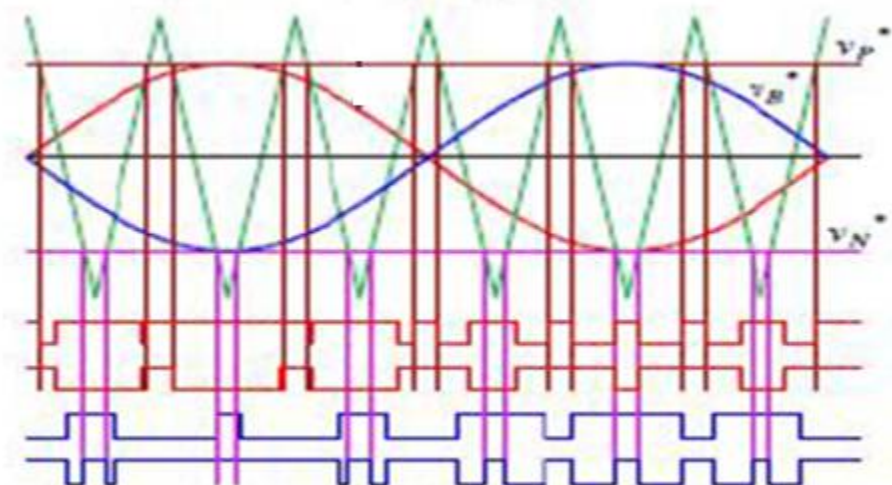

Fig.3 Maximum constant boost control strategy

International Journal of Innovative Research in Science, Engineering and Technology

(An ISO 3297: 2007 Certified Organization)

Vol. 5, Issue 8, August 2016

COMPARISON OF SC QUASI- Z- SOURCE INVERTER WITH SC/SL QUASI-ZSI

In this paper, comparison of the SC/SL quasi- Z-source inverter with SC qZSI carried out by using MATLAB. In switched capacitor quasi-Z-source inverter the impedance network constitutes only one inductor which is connected in series with the dc source. In case of SC/SL quasi-Z-source inverter it is replaced by a SC/SL cell.

Table.1 Comparison of inductance and capacitance values (Theoretical values)

Type of parameter	SC/SL- qZSI	SC- qZSI
Shoot through duty ratio(D_{sh})	0.28	0.353
Boost factor (B)	8	8
Inductance value (L_1, L_2)	1.29mH	0.62mH
Capacitance value (C)	607 μ F	720 μ F

Table 1 shows a comparison of inductance and capacitance values used in the impedance network for the same boosting conditions. The summarised value of the inductance required for the SC/SL quasi- Z-source inverter is slightly higher than the SC qZSI. The capacitance value for the topology is less than the SC-qZSI.

Table.2 Comparison of voltage stress and output voltage level

Type of parameter	SC/SL quasi-Z-source inverter	SC quasi-ZSI
Input voltage	50V	50V
Output voltage	322V	150V
Voltage stress	30V	228V

Table.2 compares the voltage stress and output voltage level of the SC/SL qZSI and SC qZSI. The voltage and current stress of impedance network vary with dc input, ac output voltages, control methods used and load conditions. The input and output voltage levels are given in the table.2 based on simulation results.

V. SIMULINK MODEL

Fig.4 shows the simulink model of SC/SL quasi-Z-source inverter and fig.5 shows the simulink model of SC quasi- ZSI. The two topologies are based on maximum constant boost control method. All the traditional pulse width modulation techniques can be used to control the quasi- Z-source inverter. The SC/SL quasi-Z-source inverter has higher boost ability as compared with the SC-quasi-Z-source inverter.

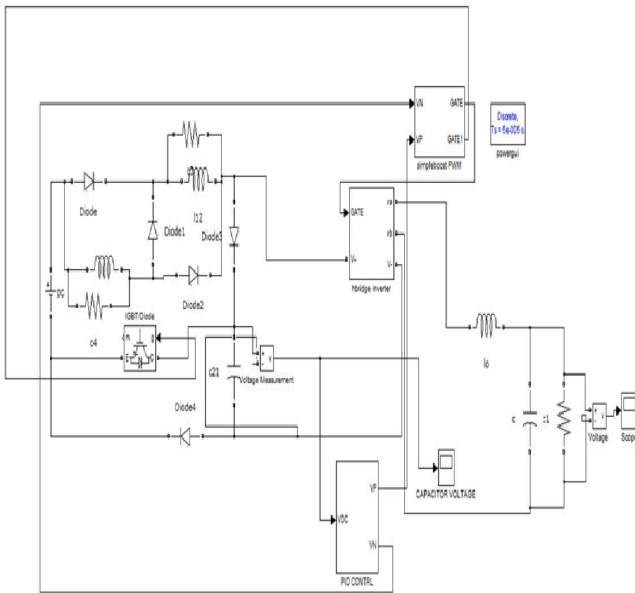

Fig.4 Simulink model of SC/SL quasi-Z-source inverter

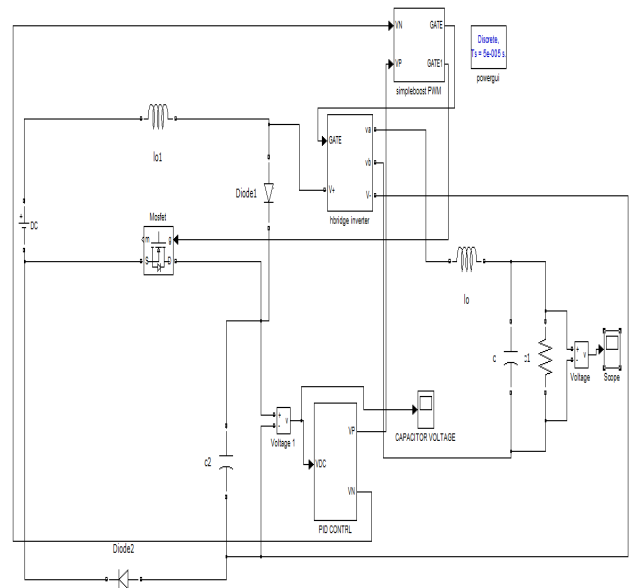

Fig.5. Simulink model of SC quasi-Z-source inverter

Modulation technique used for the two topologies is maximum constant boost control method. Simulation studies are carried out in MATLAB. The SC/SL quasi- Z-source inverter can produce an output voltage of 322V from 50V. For the same input voltage the output of the SC qZSI will be 150V.

Table .3 shows the simulation parameters for the SC/SL quasi-Z- source inverter. Modulation index (M_a) = 0.8 and Shoot through duty ratio (D_{sh}) = 0.28 in the steady state condition under maximum constant boost control method. The peak dc link voltage is same as capacitor voltage.

Table.3. Simulation Parameters

DC input voltage	50V
Fundamental frequency	50HZ
Switching frequency	5Khz
Capacitor, C	470 μ F
Inductor	1mH

VI. SIMULATION RESULTS

To compare the SC/SL quasi-Z-source inverter with SC quasi-Z-source inverter simulink software is used. Fig.6 shows the load voltage waveform of SC/SL quasi-Z-source inverter. The dc input voltage given to the inverter is 50V, output voltage can be boosted to 322V. It exhibits higher boost ability.

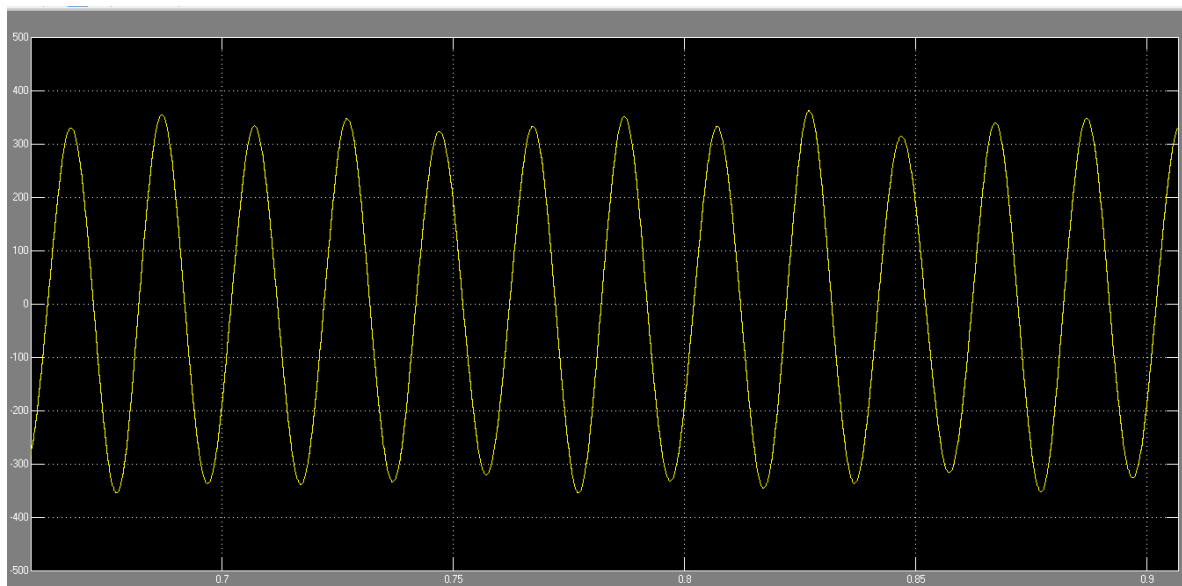

Fig. 6 Output voltage waveform of SC/SL qZSI

Fig.7 shows the output current waveform of the SC/SL quasi-Z-source inverter. In shoot through state the inductors store energy and the input and dc link current are twice the inductor current. In non- shoot through state the input current is identical to the inductor current and dc link current is same as the output current.

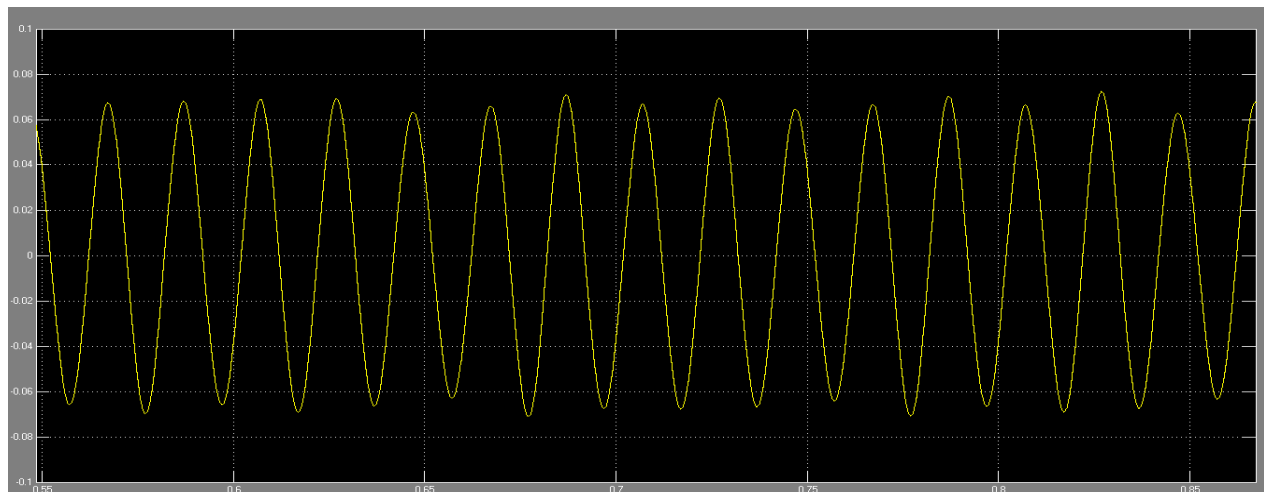

Fig.7. Output current waveform of SC/SL quasi-Z-source inverter

International Journal of Innovative Research in Science, Engineering and Technology

(An ISO 3297: 2007 Certified Organization)

Vol. 5, Issue 8, August 2016

Fig.8 shows the output voltage of the SC quasi- Z- source inverter. Modulation index ($M_a = 0.8$) and shoot through duty ratio ($D_{sh} = 0.353$) in the steady state condition under maximum constant boost control method. The output voltage can be boosted up to 150V from 50V. The dc input voltage and the peak dc link voltages are same as the capacitor voltage.

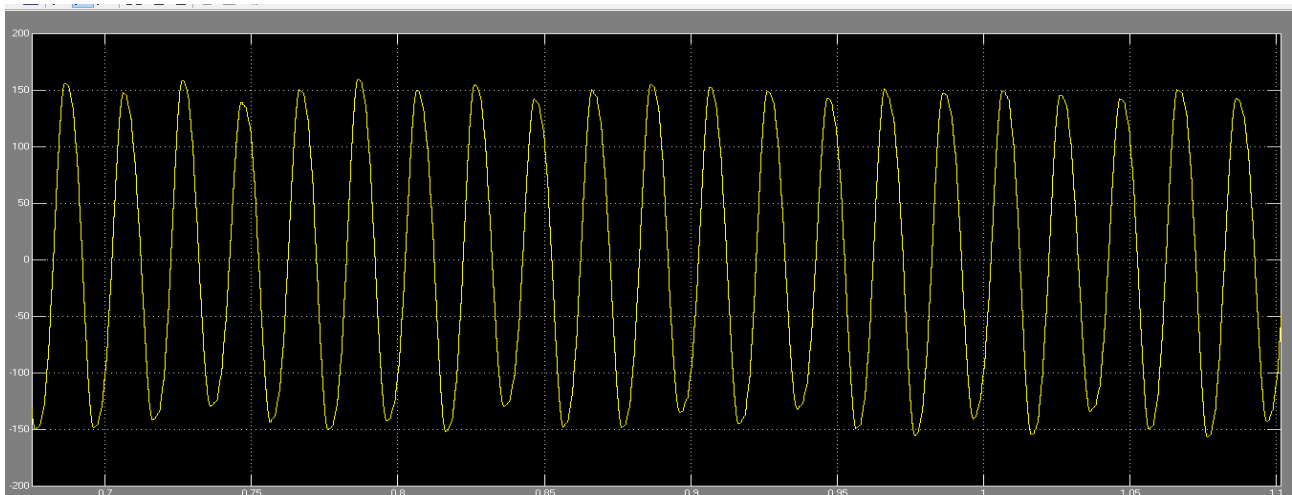

Fig.8. Output voltage of SC/quasi-Z-source inverter

Fig. 9 shows the output current of the Switched capacitor quasi-Z-source inverter. The shoot through current is always higher than the load current. The current stress across the passive elements in the impedance network depends on the value of shoot through current.

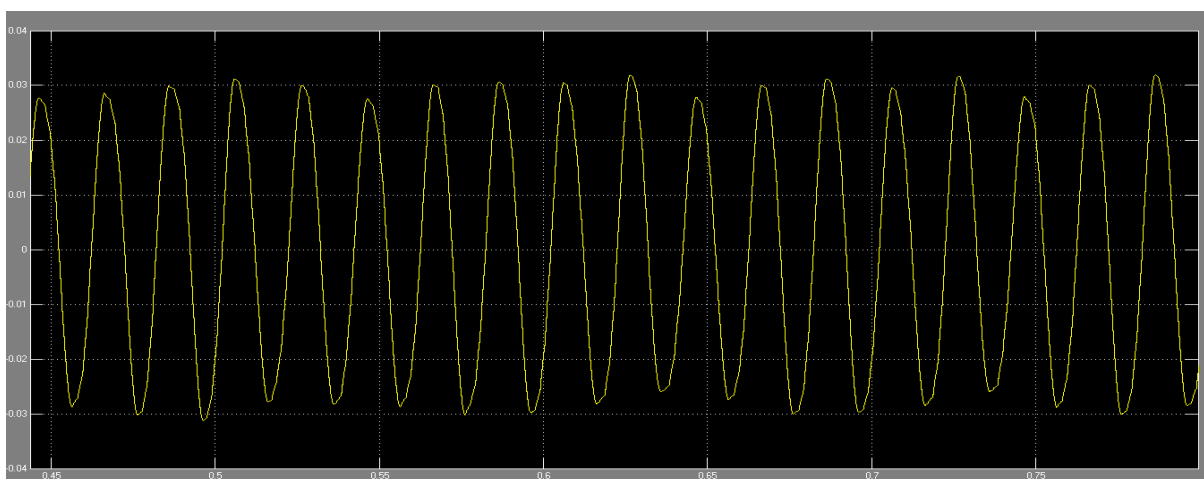

Fig. 9 Output current of SC/quasi-Z-source inverter

International Journal of Innovative Research in Science, Engineering and Technology

(An ISO 3297: 2007 Certified Organization)

Vol. 5, Issue 8, August 2016

VIII. CONCLUSION

In this paper working principle and performance of a switched inductor/switched capacitor quasi Z-source inverter is explained. And its simulation results are compared with the simulation results of SC-qZSI. To control the shoot through state maximum constant boost control method is used. The proposed scheme is simulated by using the software MATLAB/SIMULINK. The boost factor for the proposed topology is high over the whole range of shoot through duty ratio. The voltage stress across the switches is reduced in a large scale when compared with the traditional topologies. It requires fewer number of passive components as compared with existing topologies for the same dc input voltages and output voltage. The proposed topology is also expandable.

REFERENCES

- [1] Anh-Vu Ho, Tae-Won Chun, and Heung-Geun Kim, "Extended boost active- switched-capacitor/switched-inductor quasi-Z-source inverters", IEEE Transactions on power electronics, Vol. 30, No. 10, 2015.
- [2] F.Z Peng, "Z-Source Inverter", IEEE Trans. Ind. Appl., Vol. 39, No. 2, pp.504, 2003.
- [3] P. C. Loh, D. M. Vilathgamuwa, Y. S. Lai, G. T. Chua, and Y. Li, "Pulse width modulation of Z-source inverters", IEEE Transactions on Power Electronics, Vol. 20, No. 6, pp.1346-1355, 2005.
- [4] F. Z .Peng, "Z-source half- bridge inverter", IEEE Trans. Ind. Appl., Vol. 39, No. 2, pp.504 – 510, 2008.
- [5] B. Axelord, Y. Berkovich, and A. Ioinovici, "Switched-capacitor/switched-inductor structures for getting transformer less hybrid dc-dc converter", IEEE Trans. Circuits Syst. I, Reg. Papers, Vol. 55, No.2, pp. 687- 696, 2008.
- [6] C. J. Gajanayake, F. L. Luo, H. B. Gooi, P. L. So, and L. K. Siow, "Extended boost Z-source inverters", IEEE Transactions on Power Electronics, Vol.25, No.1, pp.2642-2652, 2010.
- [7] M. Zhu, K. Yu, and F. L. Luo, "Switched inductor Z-source inverter", IEEE Trans. Power Electron., Vol. 25, No.8, pp.2150-2158, 2010.
- [8] M. Kamli, S. Yamamot, and M. Abe, "A 50-150kHz half-bridge inverter for induction heating applications", IEEE Trans. Ind. Electron, Vol. 43, No. 1, pp.163-172, 1996.
- [9] D. Li, P. C. Loh, M. Zhu, F. Gao, and F. Blaabjerg, "Generalized multicell switched-inductor and switched-capacitor Z-source inverters", IEEE Trans. Power Electron., Vol. 28, No. 2, pp.837-848, 2013.
- [10] M. K. Nguyen, Y. C. Lim, and J. H. Choi, "Two switched-inductor quasi-Z-source inverters", IEEE Trans.Power Electron., Vol. 5, No. 7, pp.1017- 1025, 2015.
- [11] F. Z. Peng, M. Shen, and Z. Qian, "Maximum boost control of the Z-Source inverter", IEEE Trans. Power Electron., Vol. 20, No. 4, pp.833-838, 2005.
- [12] M. Shen, J. Wang, A. Joseph, F. Z. Peng, L. M. Tolbert, and D. J Adams, "Constant boost control of the Z-source inverter to minimize current ripple and voltage stress", IEEE Trans. Ind. Appl., Vol. 42, No. 3, pp.770-778, 2006.
- [13] J. Anderson, and F. Z Peng, "A Class of quasi-Z-source inverters", in Proc. Conf. Rec. IEEE – IAS Annu. Meeting, pp.1-7, 2008.

BIOGRAPHY



Nishamol P T was born in Kerala in 1987. She received the B.Tech degree in Electrical and Electronics Engineering from Cochin University college of engineering kuttanadu, Kerala, India, in 2010. She is presently doing M. Tech in KMEA College of Engineering, Edathala, kerala.