

International Journal of Innovative Research in Science, Engineering and Technology

(An ISO 3297: 2007 Certified Organization)

Vol. 5, Issue 8, August 2016

Linear Static Analysis of Truck Chassis

Udhay Kiran S¹, Mahesh Kumar Matin²

P.G. Student, Department of Mechanical Engineering, Kuppam Engineering College, Kuppam, Chittoor, India¹

Assistant Professor, Department of Mechanical Engineering, Kuppam Engineering College, Kuppam, Chittoor, India²

ABSTRACT: The project aim is to design and analysis of a leader type truck (TATA ACE model) chassis. The Automotive chassis is considered as the backbone of the vehicle. On chassis different members are provided to strengthen it and an important consideration in chassis design is also to have adequate bending stiffness for supporting the body and different parts of the automobile. Also, it should be rigid enough to withstand the shock, twist, vibration and other stresses. Strength and the stiffness are the two important criteria for the design of the chassis. The cross member is also analysed for the deflection due to bending

The chassis frame consists of side members attached with a series of cross members. And the design of the chassis would be taken in the CATIA V5 software, the design calculations are carried out with the IS standards. FEA is done on the modelled chassis using the NASTRAN PATRAN Workbench; the FEA is carryout for linear static analysis of the chassis. Also Stress analysis using Finite Element Method can be used to locate the critical point which has the highest stress. This critical point is one of the factors that may cause the failure.

KEY WORDS: Chassis, Catia, Nastran-Patran, FEA.

I. INTRODUCTION

The chassis forms the backbone of the dump truck and its chief function is to safely carry the maximum load, whether the vehicle is in static or dynamic condition. There are some advantages of off-road vehicles chassis over other chassis. The truck chassis is the main system of the vehicle and it is integrated with the main truck component systems such as the axles, suspension, power train, cab and body. The truck chassis has been loaded by static, dynamic and also cyclic loading. The existing truck chassis design is normally designed based on static analysis. The emphasis of this design is chiefly on the strength of structure to support the loading placed upon it. However, the truck chassis is loaded by complex type of loads, including static, dynamic and fatigue aspects. It is estimated that fatigue is responsible for 85 to 90% of all structural failures (or) crack propagation on the chassis. The objective of this research work is mainly focus to determine the fatigue life and static analysis on the heavy duty truck chassis. Localized system analysis techniques have been applied on the critical areas in order to find the more reliable, more accurate and faster ways of simulation.

Stress analysis is carried out on the chassis to find the critical point having maximum stress [3]. Critical point calculation is crucial as it causes fatigue failure of the chassis frame. In this paper, static finite element analysis is carried out on N1 type Vehicle, TATA Ace chassis. This analysis determines the deflection of chassis members due to static forces including its self-weight and also calculation of bending stiffness of chassis.

The CAD model of chassis was made using CATIA software using most approximate dimensions.

II. FINITE ELEMENT ANALYSIS

2.1 Basic Concept of FEA

Finite Element Analysis has now become an integral part of Computer Aided Engineering (CAE) and is being extensively used in the analysis of many tedious real time problems. The field of finite element analysis is matured and depends on rigorous mathematical foundation. Many powerful software tools and packages are available, promoting its widespread use in industries [4][7].

International Journal of Innovative Research in Science, Engineering and Technology

(An ISO 3297: 2007 Certified Organization)

Vol. 5, Issue 8, August 2016

2.2. Basic Calculation

Model: Tata ace

Length of vehicle = 3800 mm, Width of vehicle = 1500 mm

Height of vehicle = 1845 mm, Wheelbase = 2100 mm

Track width-Front = 1300 mm, Track width-Rear = 1320 mm

Material of chassis = structural steel

Young's modulus = 2×10^5 , Poisson's ratio = 0.3

Length of chassis = 4201 mm, Width of chassis = 808 mm

Gross vehicle weight (G.V.W) = 2250 kg = $2250 \times 9.81 = 22072.5N$

Kerb weight = 1200 kg

$$\text{For the application of the load on the chassis} = \frac{G.V.W}{2} = \frac{22072.5}{2}$$

$$= 11036.25N$$

$$\text{Capacity of the truck with 1.25\%} = 11036.25 \times 1.25$$

$$= 13795.31N$$

$$\text{Uniformly Distributed Load (U.D.L)} = \frac{13795.38}{3800} = 3.63N/mm$$

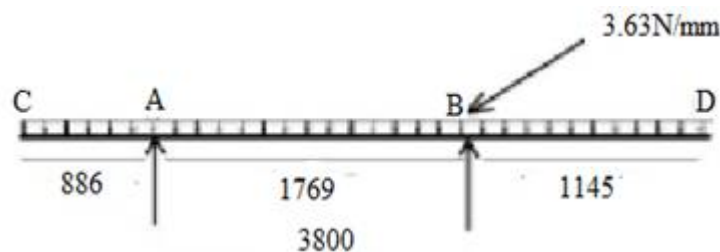

Fig.1 Reactions generated on the beam

2.3 Find out the Reaction forces

$$R_A + R_B = 3.63 \times 3800 = 13794N$$

$$R_A + R_B = 13794N$$

Taking moment at A., Consider $\sum_A = 0$

$$R_B \times 1769 - 3.63 \times \frac{2914^2}{2} + 3.63 \times \frac{886^2}{2} = 0$$

$$R_B \times 1769 - 15.4 \times 10^6 + 1.42 \times 10^6 = 0$$

$$R_B \times 1769 - 15.4 \times 10^6 + 1.42 \times 10^6 = 0$$

$$R_B = \frac{13.98 \times 10^6}{1769} \quad R_B = 7900N$$

We know that

$$R_A + R_B = 13794N \quad R_A = 13794 - 7900N$$

$$R_A = 5894N$$

International Journal of Innovative Research in Science, Engineering and Technology

(An ISO 3297: 2007 Certified Organization)

Vol. 5, Issue 8, August 2016

2.4 Modelling of the existing chassis

In order to proceed with this study, the dimensions of the chassis were gathered from the Tata Ace model. The 3D model of the chassis was designed in CATIA V5

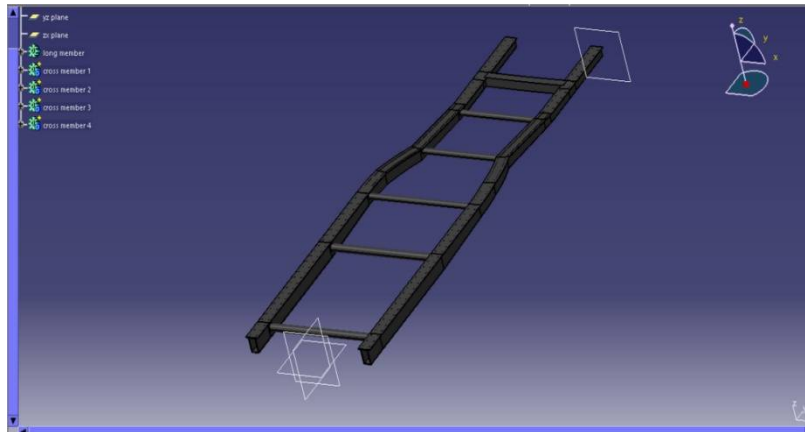

Fig.2 CAD model of the chassis

2.5 Analysis in Nastran Patran

2.5.1 Engineering properties of material

Structural steel properties required for analysis are mentioned in the following table[5]

S.No	Mechanical Properties	Value	Unit
1	Young's Modulus	270	GPa
2	Poisson's Ratio	0.33	-
3	Ultimate Strength	460	MPa
4	Yield Strength	250	MPa
5	Density	7850	Kg/m ³

Table 1: properties of the materials

2.5.2 Meshing

Meshing of the chassis is shown in the following fig.

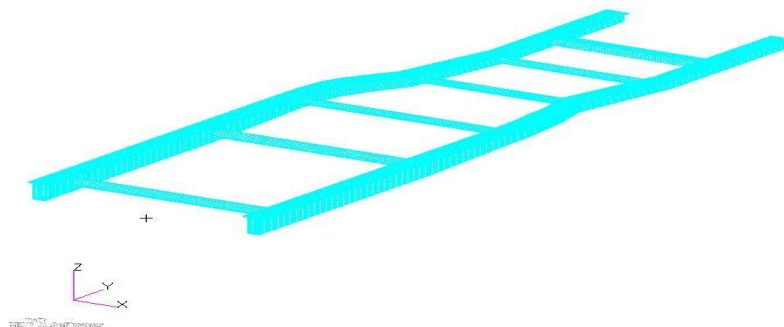

Fig 3 mesh of chassis

International Journal of Innovative Research in Science, Engineering and Technology

(An ISO 3297: 2007 Certified Organization)

Vol. 5, Issue 8, August 2016

2.6 Load determination

The truck chassis model is loaded by static forces from the truck body and load. For this model, the maximum loaded weight of truck plus body is 2250 kg. The load is assumed as a uniform distributed obtained from the maximum loaded weight divided by the total length of chassis frame. Detail loading of model is shown in Figure. The magnitude of force on the upper side of chassis is 11036.25 N. Earth gravity is also considered for the chassis frame as a part of loading. There are 4 boundary conditions of model; the first two boundary conditions are applied in front of the chassis, the second and the third boundary conditions are applied in rear of chassis, there are shown in Figure.[6]

Particulars	Weight(kg)
Chassis self weight	61.75
Engine Transmission Assembly	105
Propeller Shaft	5
Fuel Tank(Completely filled)	35
Steering assembly	28.5
Cabin weight(with driver)	205
Battery	6
Exhaust assembly	7
Tool box	4
Radiator	12

Table 2 Weight of the parts

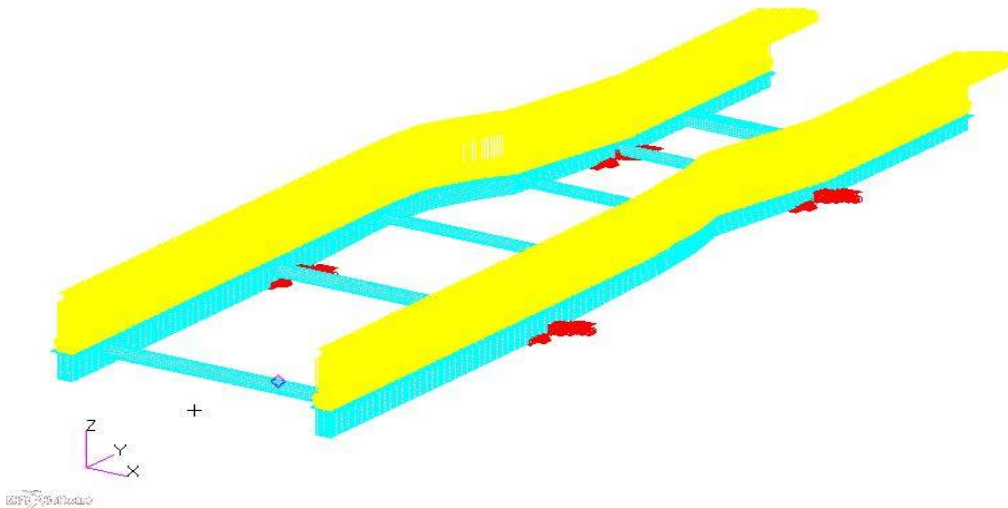

Fig 4 Loads and Boundary Conditions

After examining the mounting of the above components and their weight distribution across the mounting points, final load acting on cross members and long members were calculated

III. PROCEDURE

For analysis, the ladder frame is required to be imported into any analysis software package. We used Nastran Patran workbench and following steps are carried out for the analysis.

1. Creation of the project for the structural analysis respectively.
2. Selection of material from the engineering data.
3. Specifying Meshing Properties.

4. After generating the mesh, application of boundary condition such as fixed supports
5. After updating the project for the given boundary conditions and results are obtained.
6. Similarly each cross member was analysed for bending deflection.

IV. RESULTS

4.1 Chassis with Uniform cross section

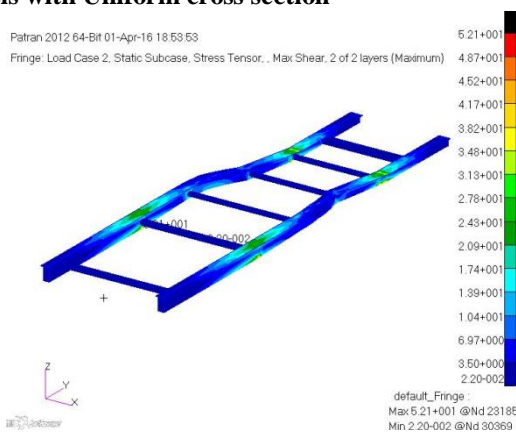

Fig 5 Chassis max shear stress

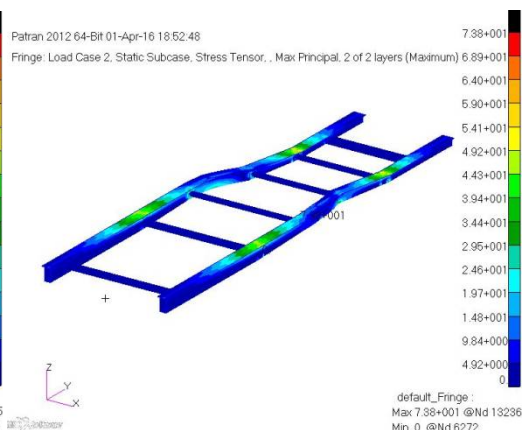

Fig 6 Chassis max principal stress

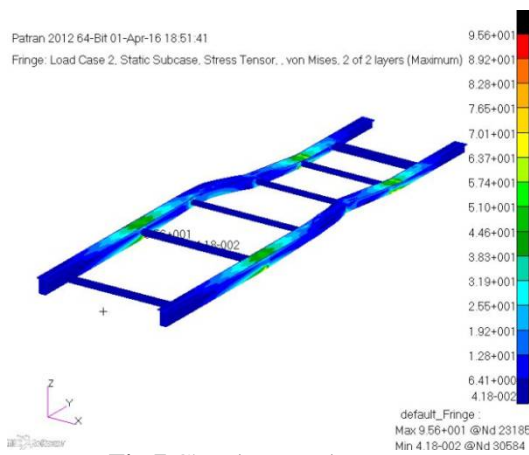

Fig 7 Chassis von mises stress

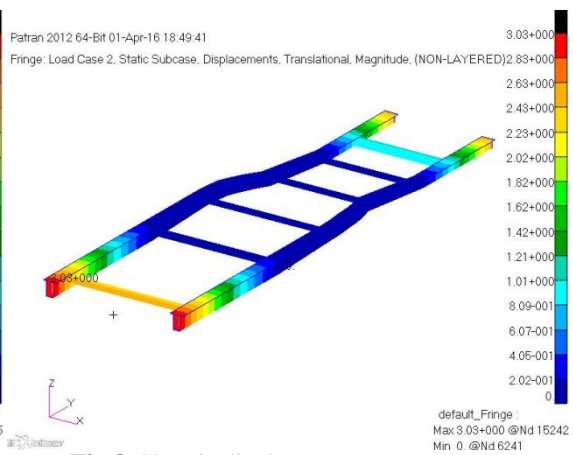

Fig 8 Chassis displacement

The fig.5-8 shows the variations of the shear stress, principal stress, von mises stress and the displacement of the chassis with the uniform cross section.

4.2 Chassis with Varying cross section

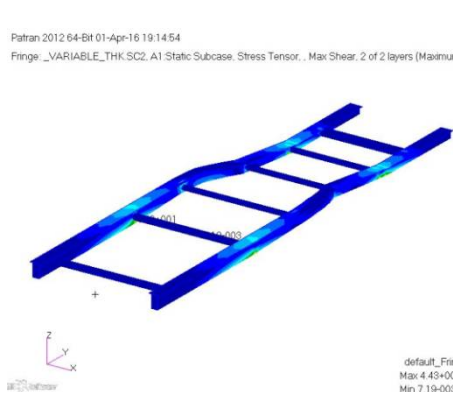

Fig 9 Chassis max shear stress

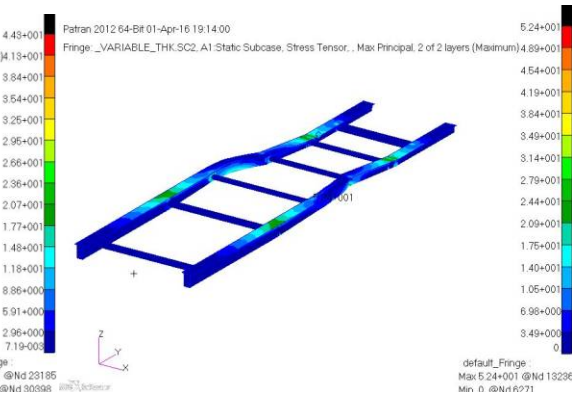

Fig 10 Chassis max principal stress

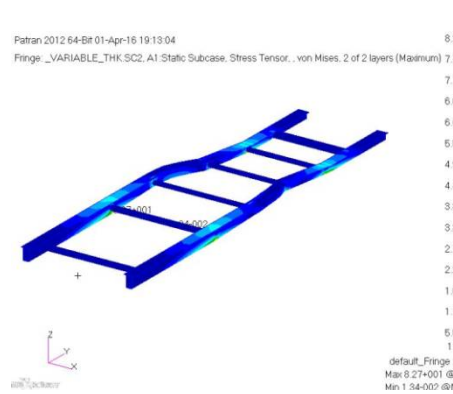

Fig 11 Chassis von mises stress

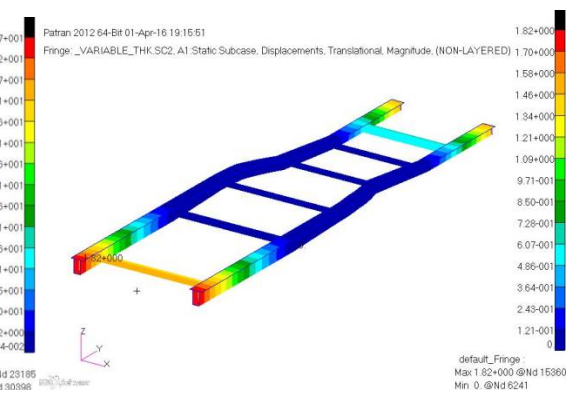

Fig 12 Chassis displacement

The fig.9-12 shows the variations of the shear stress, principal stress, von mises stress and the displacement of the chassis with the varying cross section.

4.2 Chassis with C-section

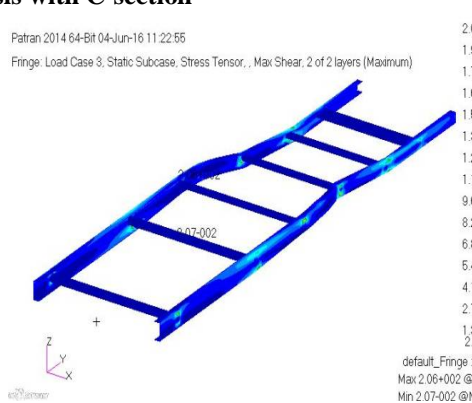

Fig 13 Chassis max shear stress (C-section)

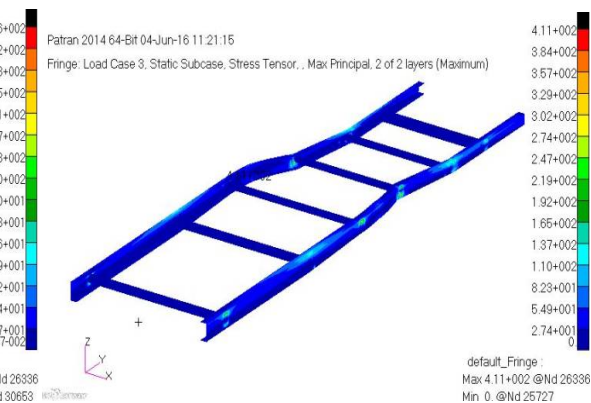
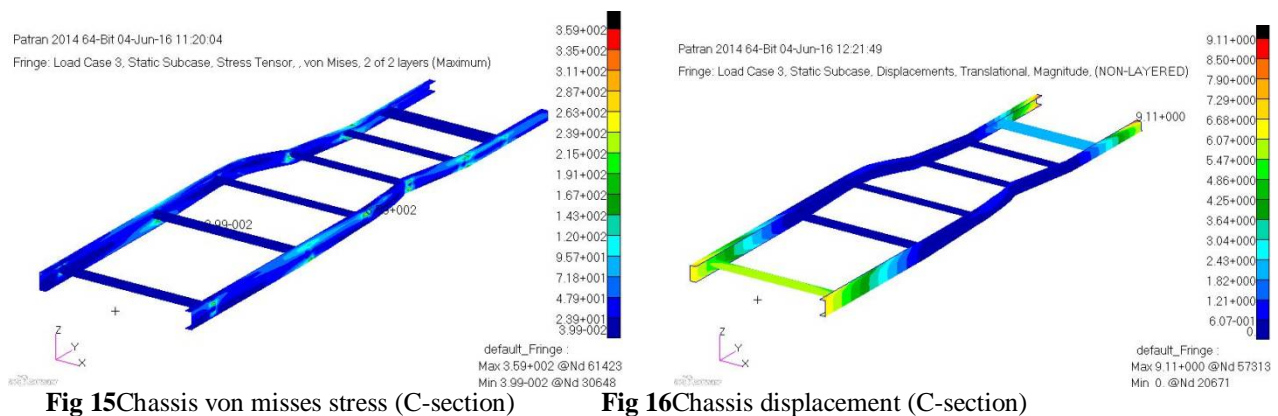

Fig 14 Chassis max principal stress (C-section)



The fig.13-16 shows the variations of the shear stress, principal stress, von misses stress and the displacement of the chassis with the C- section.

V. CONCLUSION

The modal analysis and static structural analysis on the Tata Ace ladder chassis was carried out. In the present work, ladder type chassis frame for TATA Ace Truck was analysed using Nastran Patran software. From the results, it is observed that the Rectangular Box section is having more strength than C -section type of Ladder Chassis

The Rectangular Box Cross-section Ladder Chassis is having least deflection i.e., 1.82 mm and least Von Misses stress and Maximum Shear stress i.e., 82.7MPa & 44.3MPa respectively. The overall bending stiffness of the Chassis is 11224 N/m which is under 22000 N/m, permissible range for N1 Vehicle Category.

Based on the analysis results of the present work, the following conclusions can be drawn.

- 1) Part is safe under the given loading condition.
- 2) To improve performance, geometry has been modified which enables to reduce stress levels marginally well below yield limit.
- 3) The generated Von Misses Stress & Maximum Shear Stress is less than the permissible value so the design is safe for all three materials.
- 4) The Rectangular Box Cross-section Type of Ladder Chassis is having least deflection, Von Misses stress and Maximum Shear stress for Steel in all the of three different cross section type of Ladder Chassis.

REFERENCES

- [1] Avinash V. Gaikwad, Pravin S. Ghawade finite element analysis of a ladder chassis frame@ijetmas, volume 2 issue 6, issn 2349-4476, november 2014
- [2] B. Ramya, Sridhar Reddy, Dr. C. Udaya Kiran design and structural analysis of chassis ijedr | volume 2, issue 4 | issn: 2321-9939© 2014
- [3] V. Vamsi Krishnam Raju, B. Durga Prasad, M. Balaramakrishna, Y. Srinivas Modelling structural analysis of ladder type heavy vehicle frame @ | ijmer | issn: 2249-6645 | vol. 4 | iss. 5 | may. 2014
- [4] P K Sharma, Nilesh J. Parekh, Darshit Nayak Optimization and stress analysis of chassis in TATA Turbo truck SE1613@ IJEAT, Volume3, Issue-3, ISSN:2249-8958, Feb 2014.
- [5] Manpreet Singh Bajwa, Yatin Raturi, Amit Joshi static load analysis of tata super ace chassis and its verification using solid mechanics @ iraj international conference, Delhi chapter- 26th, isbn: 978-81-927147-5-2, may 2013
- [6] Chinmay Potdar, Aishwarya Dubey, Sushrut Jadhav evaluation of deflection due to bending of n1 type vehicle chassis members using static finite element analysis @ proceedings of 46th irf international conference, isbn: 978-93-85832-97-0, 27th december 2015, pune, india,
- [7] Mukesh Patil, Rohit Thakare, Aniket Bam analysis of a tanker truck chassis @ ijmer|, volume-3, issue-6, issn (print): 2321-57472015
- [8] A.Hari Kumar, V.Deepanjali design & analysis of automobile chassis @ ijesis volume 5, issue 1, issn: 2319-5967, january 2016