

Static Analysis of Lift Equipment with Turn Table Attachment

Manjunath S Haradagatti¹, Suhas B²P.G. Student, Department of Mechanical Engineering, MVJ College of Engineering, Bengaluru, India¹Assistant Professor, Department of Mechanical Engineering, MVJ College of Engineering, Bengaluru, India²

ABSTRACT: The axle on which CNC operation was to be conducted was placed on top of lift table of equipment. For few operations the axle was supposed to be rotated for 90 degrees for which the entire equipment was supposed to be rotated during which there was misalignment of CNC reference and also the aisle width of track was less frequently turning the equipment was difficult and in few sub-assemblies the parts were over designed. In order to add value to the product and to sort out the issues it had. The concept of turn table with hydraulic actuation is designed. The complete design study is done on actual design and over material weight is reduced wherever necessary and this material and fabrication cost savings is invested on building the turn table attachment. Here we have conducted the static analysis by using the HyperMesh as pre-processor software and Optistruct as postprocessor, also we have compared the FEA and theoretical results.

KEYWORDS: Lift Equipment, Top Frame, Scissor arm, Support Frame, Base assembly, Turn table, Static analysis, Optistruct.

I. INTRODUCTION

The first kind of these concepts were developed in bulk material handling equipment like Conveyor turntables in early 19th century mainly in automation industries mainly in Food processing industries, Conveyor turntables are generally located inside.

Turn table attachments are generally used in material handling equipment like Forklifts, Scissor lift tables, manual / Semi-automatic / fully automatic stackers and various other types of lift equipment. Currently similar kind of concepts is used in major manufacturing industries in order to load dies. In production operations and various activities were the products to be worked on are loaded in turn tables which is operated hydraulically.

An Axial Manufactured Turntables leads an efficiency and appropriate results to manufacturing line. Designed to fulfil an effortlessly when floating and moving the more loads, there will be a turntable structure it will adopt seamlessly into the process flow. Mechanical turntables using a slip bearing and wheels if needed, are one more option, seeing as they gives an outdoor advantages and can run continually while staying energy efficient. While an Axial offers a standard line of products, customers look to us to design custom solutions that can be integrated into their systems.

Raymond A. Kulwiec.[1].He has discussed that material handling equipment should be selected to support the type of manufacturing layout is to be used. A job-shop or batch production line, ex: industrial trucks, overhead cranes, those are which to be used for handling the material movement. The material handling equipment used to support the operations tends to be of general purpose type. A line or flow pattern is more structured and sequenced.

II. LITERATURE SURVAY

The first type manually operated turn tables were design by Liftec Equipment's located in China in 1950's. The same concept is still used by major equipment manufactures. In mid-90's in order to market the automobile vehicles. An motor gear driven powered by electrical was development by German material handling manufacturers which were mainly used in automobile showrooms were Vehicles were showcased by placing it on turn tables and rotated by 360°.

International Journal of Innovative Research in Science, Engineering and Technology

(An ISO 3297: 2007 Certified Organization)

Vol. 5, Issue 8, August 2016

John Vangle and Will Lynn [2]. In their paper they have discussed about the turntable provision of means for revolving the turn table of the press by motive power, and automatically stopping the table at each half revolution. More specifically stated, the invention embodies amongst other features, a belt driven shaft, supporting a fixed pulley and an idle pulley, the. Belt being automatically shifted from one pulley to the other incident to the operation of the means which automatically stops the turn table, the latter being released and the belt again shifted .by means of a manually operable element.Silva, F. B.; Barros, M. M. S. B. Av. Prof. Almeida Prado. [3] in their paper they have discussed about the process planning for the product development cycle in the manufacturing industry, the process planning is the process that takes place within the manufacture system design, which consist of defining how will be the product is to be manufactured, in this which includes that how the production process will be take place sequentially. Meyers, F. E. (2005) [4]. In this book he has given the clear idea about the metal handling techniques and procedure for the developing the efficient facility layout, and also they have told about the time and motion economy for balancing the assembly lines and handling the workload in manufacturing unit.

III.PROBLEM DEFINITION

In this work we have taken the cad model which is created by Creo CAD Tooland we have carried out the static analysis of Lift equipment components to find the maximum stress and the maximum deflection. The static analysis has done by using the HyperMesh as a pre-processor, Optistruct as the solver and HyperView as the post processor.And then we have compared of FEA analysis and theoretical results.

IV. METHODOLOGY

PRILIMINARY DESIGN CONSIDERATIONS:

Specifications		
Sl. No.	Description	Details
1	Turn table attachment	Yes
2	Maximum lift height	1200 mm
3	Minimum lift height	350 mm
4	Pay load capacity	800 Kg
5	Wheel base	2325 mm
6	Drive wheel diameter	300 mm
7	Front wheel diameter	80 mm
8	Lift speed	80mm per min.
9	Support frame	Sheet metal bend
10	Stand on platform	Available

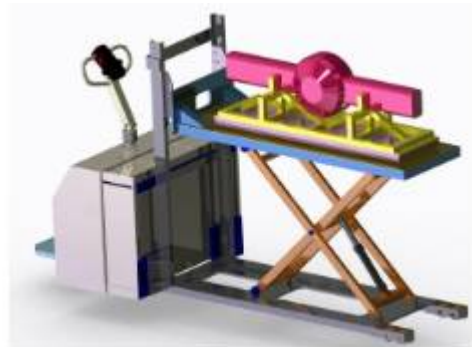

Material used : IS2062 steel
Density at room temperature: $7.9 \times 10^9 \text{ ton/mm}^3$
Modulus of elasticity : $2.1 \times 10^5 \text{ N/mm}^2$
Yield strength : 240 N/mm^2
Poisson's ratio : 0.3

Table. 01 Specification of Lift Equipment

Fig 01. Isometric view of Lift Equipment.

The components of Lift equipment are created by using the Creo and geometry is imported to FE tool HyperMesh, The FE model is created by using 2D shell elements and 3D tetra elements. And model setup was carried out for static analysis by creating the load step and load collectors with boundary conditions applied. And was compiled in Optistruct solver to get the results. These results are then viewed in the HyperView.

International Journal of Innovative Research in Science, Engineering and Technology

(An ISO 3297: 2007 Certified Organization)

Vol. 5, Issue 8, August 2016

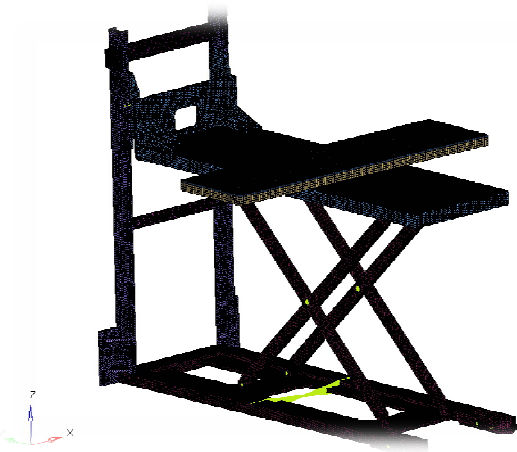

Fig 02. Isometric view of FE Model

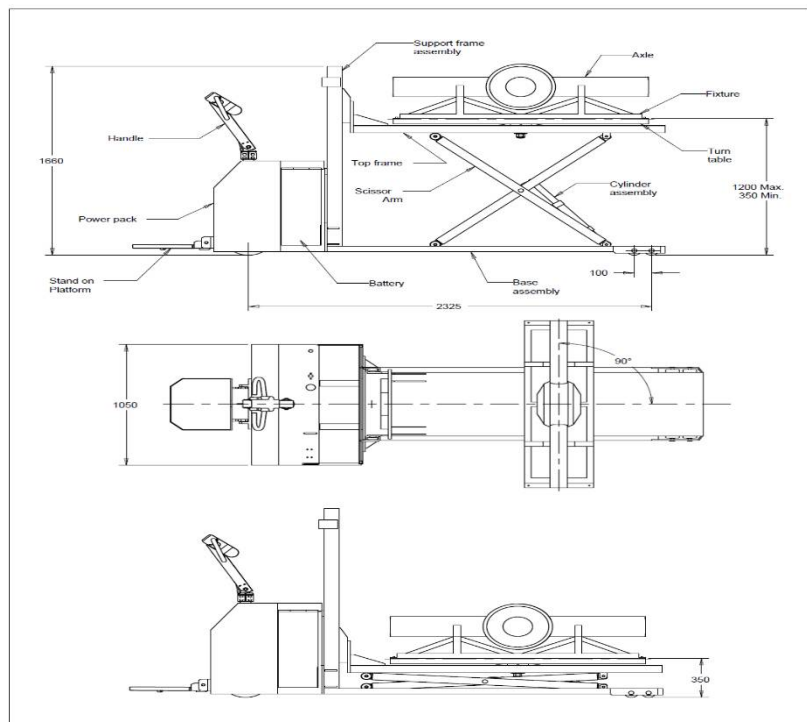

Fig 03. Detailed drawing Lift equipment.

V. SIMULATION AND RESULTS

1. ANALYSIS FOR TOP FRAME AT MAX. HEIGHT:

Here we have consider the top frame as the simply supported beam as shown in fig.04

So the moment of inertia for the top frame section x-x is $I=976425.33 \text{ mm}^4$ and section modulus at top section at $\bar{y}=44.5\text{mm}$ is $Z=21942.14 \text{ mm}^3$

And Bending moment $M_b = w * a * b / L = 8000 * 542 * 445 / 987 = 1.95493 * 10^6 \text{ N-mm}$

Stress, $\sigma = Mb / z = 1.95493 * 10^6 / 21942 = 89.095 \text{ MPa}$

Deflection at the location of load, $Y = W a^2 b^2 / 3 EIL = 0.76797 \text{ mm}$

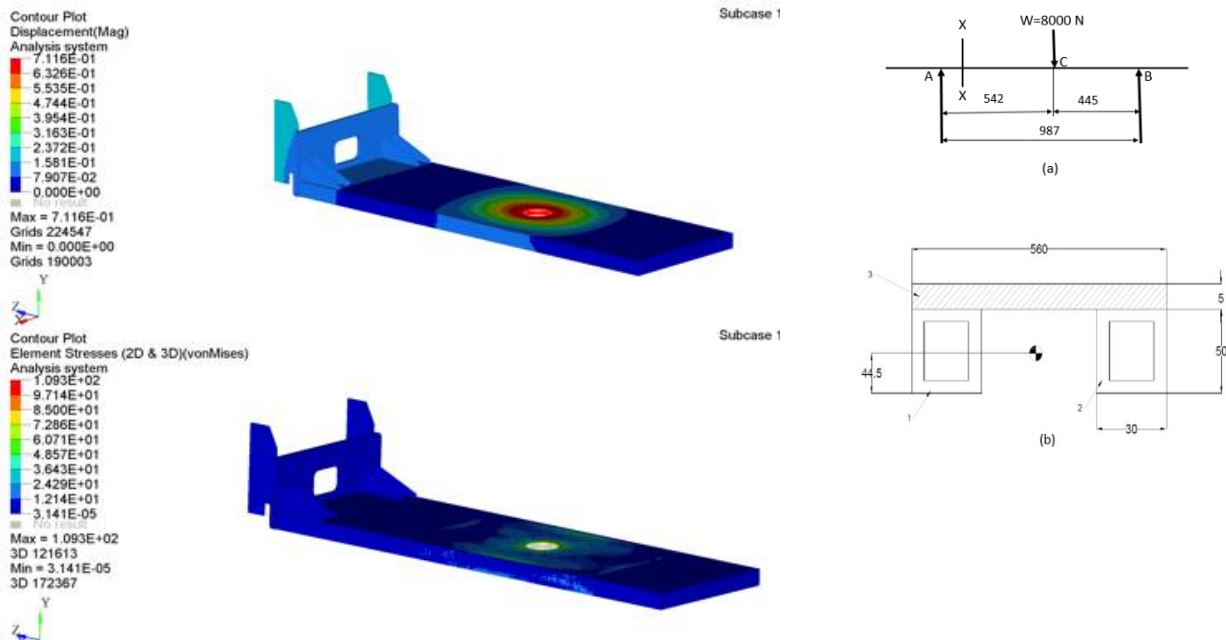

Fig. 04 Vonmises stress and deflection for top frame at max. Height;(a) load acting on top frame, (b) section X-X

2. ANALYSIS OF SCISSOR ARM.

For the scissor arm we have considered as the cantilever beam as show in fig.05 (b).

Load=8000 N

Length = 685mm

Value of load P

$I = 282218.66 \text{ mm}^4$; $Z = 282218.66 / 30 = 9407.28 \text{ mm}^3$

$P = 4000 \times \sin 44$

$M_b = 2778.63 \times 685 = 1.903361 \times 10^6 \text{ N-mm}$

$P = 2778.63 \text{ N}$; $\sigma = Mb / Z = 1.903361 \times 10^6 / 9407.28 = 202.32 \text{ Mpa}$; Deflection, $y = Pl^3 / 3EI = 5.023 \text{ mm}$.

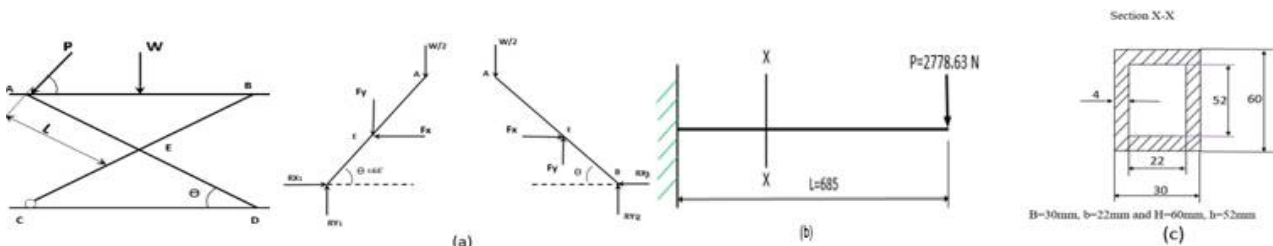

Fig.05 (a) Force resolving, (b) Scissor arm as cantilever beam, (c) Section X-X of Scissor arm.

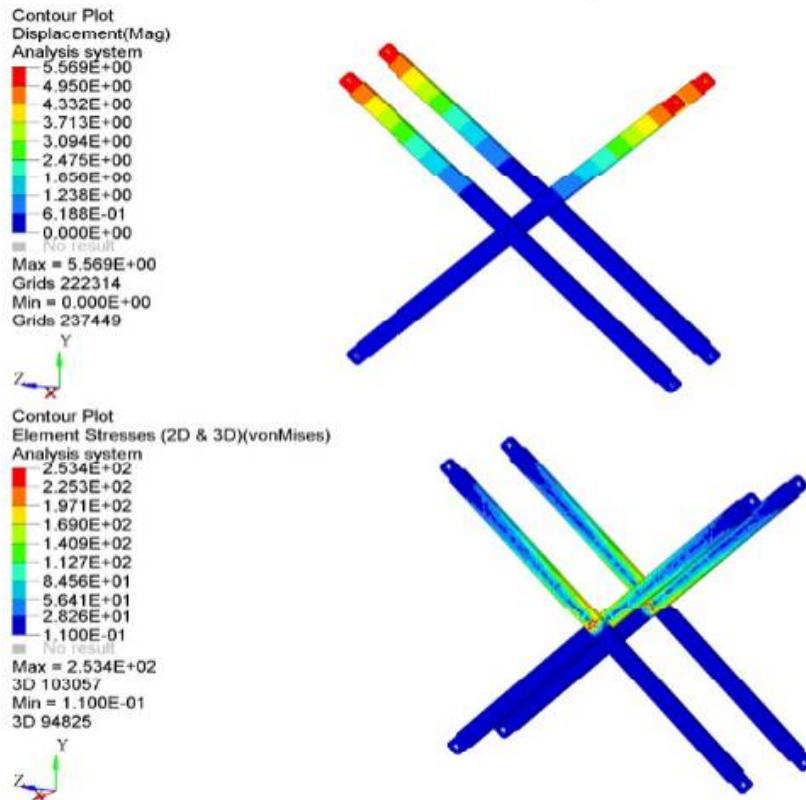

Fig. 06 Vonmises stress and deflection for the scissor arm.

3. ANALYSIS OF SUPPORT FRAME:

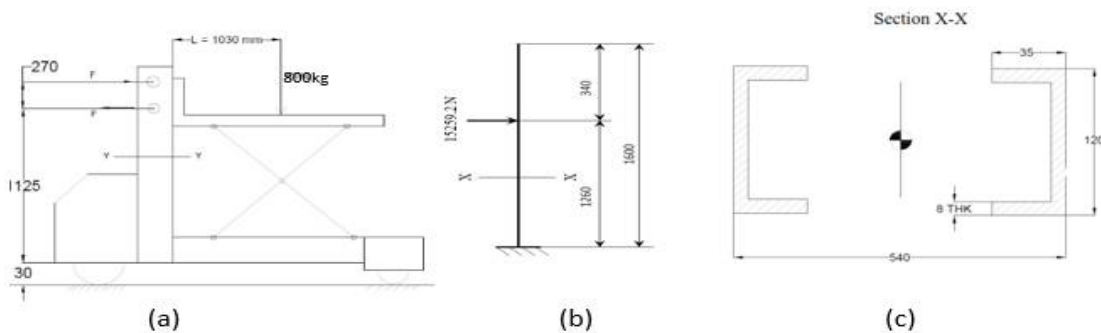

Fig.07 (a) Analysing the forces on support frame,(b) Support frame as cantilever beam. (c) Section X-X respectively
 $W * L = 2 * F * a = 800 * 1030 = 2 * F * 270$; So, $F = 15259.2 \text{ N}$
 $I = 5.018 * 10^6 \text{ mm}^4$ $M_b = 15259.2 * 1260 = 19.22 * 10^6 \text{ mm}^4$ $Y_{\text{max}} = Fa^2 * (3L-a) / 6EI = 13.563 \text{ mm}$
 $Z = 83635.2 \text{ mm}^3$; $\sigma = Mb / Z = 229.80 \text{ MPa}$.

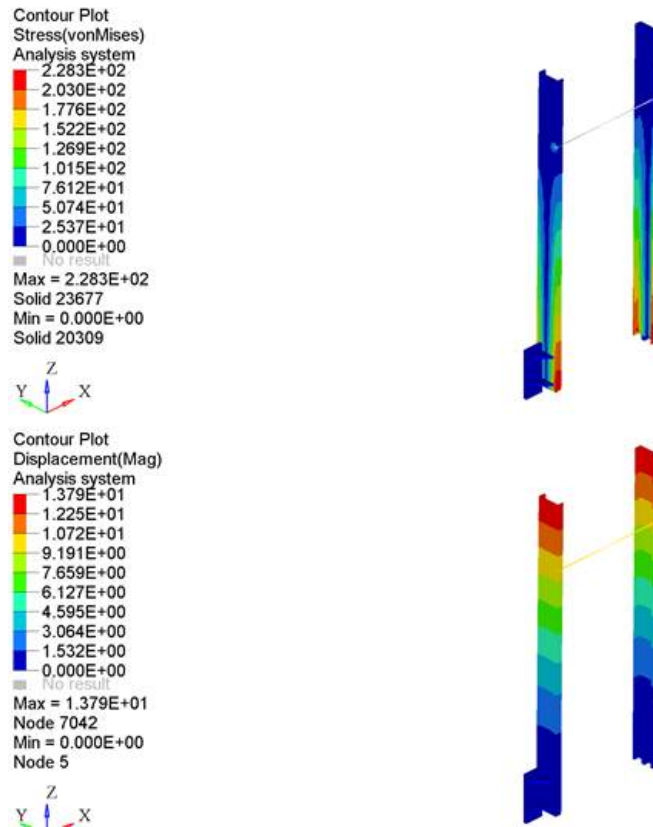

Fig. 08 Vonmises stress and deflection for Support frame.

4. ANALYSIS OF BASE ASSEMBLY.

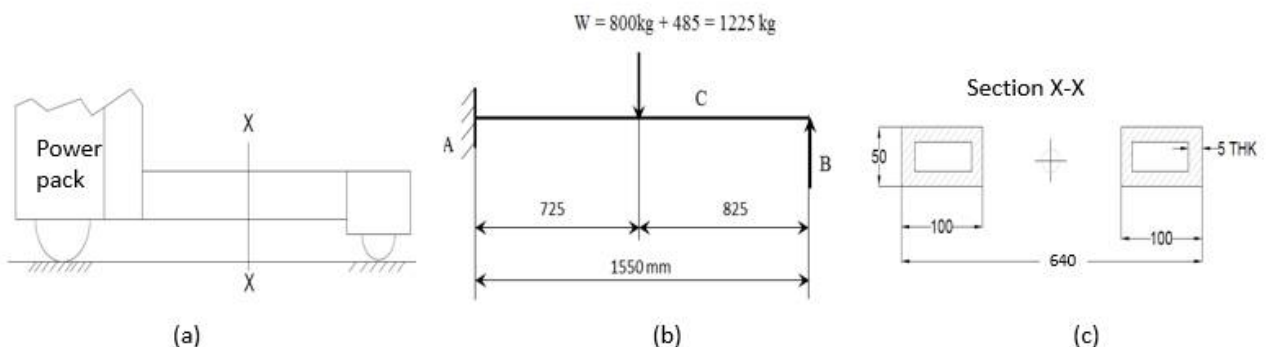

Fig. 09. (a) Base assy support on wheel and fixed to power pack; (b) Load acting on the base assy; (c) Section X-X
Data: $P=8000+4850=12250\text{ N}$; $L=1550\text{ mm}$; $a=825\text{ mm}$; $b=725\text{ mm}$; $R_B = \frac{Pb^2}{2L^3} [a + 2L] = 3396.5\text{ N}$; $R_A = 8853.5\text{ N}$
 $I = 2 * [(100 * 50^3/12) - (90 * 40^3 / 12)] = 1.12333 * 10^6\text{ mm}^4$; $Z=44933.33\text{ mm}^3$

Bending moment at Load point $M_1 = R_B * a = 2.8 * 10^6\text{ N-mm}$

Bending moment at Fixed point, $M_2 = Pab / 2L^2 (a + L) = 3.6215 * 10^6\text{ N-mm}$. The max bending moment is considered for design; Stress, $\sigma = Mb / Z = 80.59\text{ MPa}$; Deflection $Y_{\max} = [Pa^3 b^3 / 12 EIL^3] [3L + a] = 1.6506\text{ mm}$

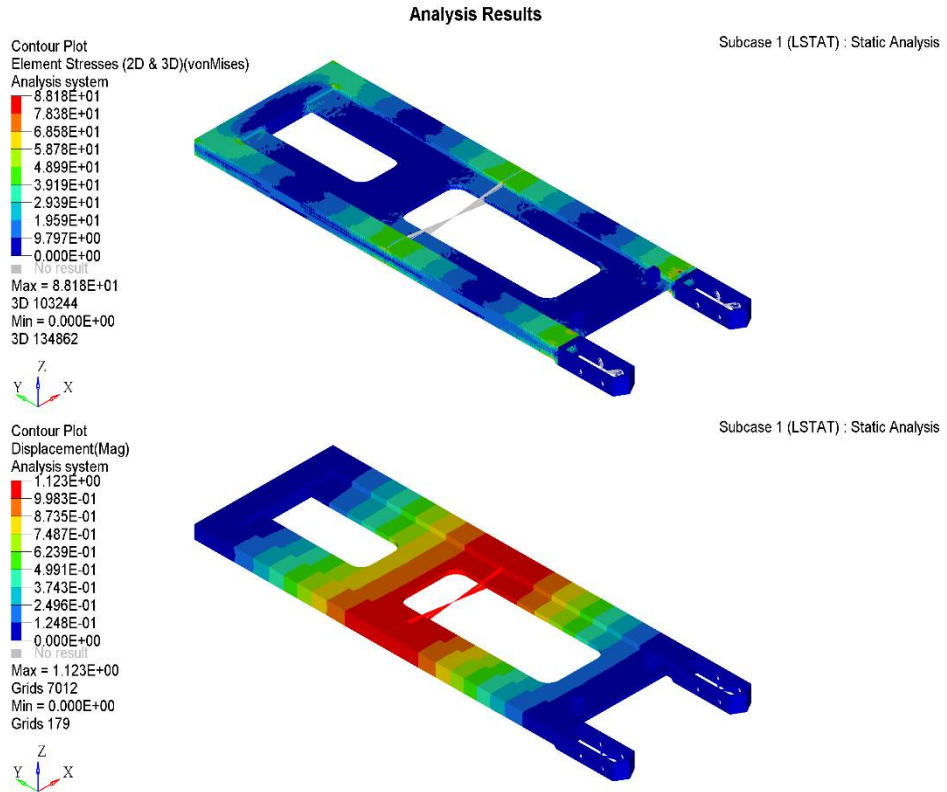
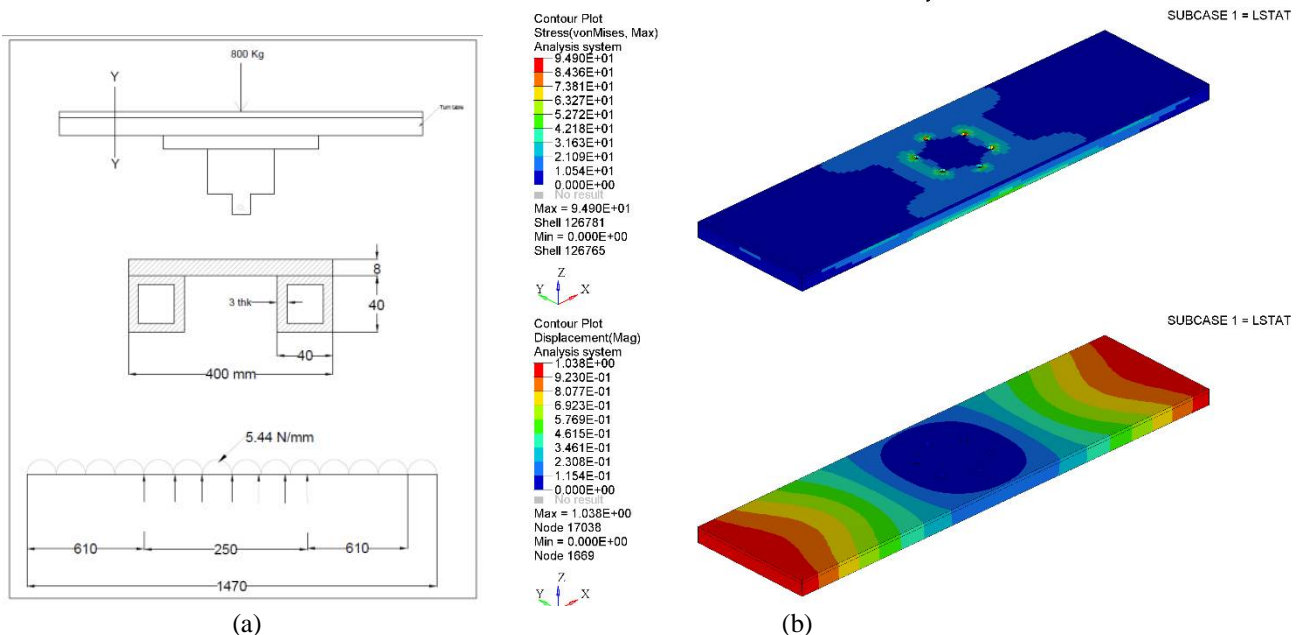

Fig.10 Vonmises stress and deflection for the Base assembly.

5. ANALYSIS OF TURN TABLE.



International Journal of Innovative Research in Science, Engineering and Technology

(An ISO 3297: 2007 Certified Organization)

Vol. 5, Issue 8, August 2016

ANALYTICAL AND FEA RESULT COMPARISON:

Sl. No.	Description	Theoretical Results		FEA Results	
		Stress in Mpa	Deflection in mm	Stress in Mpa	Deflection in mm
1	Top frame assembly	89.095	0.76797	109.3	0.711
2	Scissor arm	202.32	5.023	253.4	5.569
3	Support frame	229.88	13.563	228.3	13.79
4	Base assembly	80.59	1.651	88.18	1.123
5	Turn Table	NA	NA	94.89	1.038

Table. 02 Analytical and FEA Results comparison.

VI. CONCLUSION

From the above results we have found that all the stresses are less than the Yield stress 240MPa of the material IS2062 steel, so the design of all analysed components of the Lift Equipment are safe. Also we have compared the all the analytical and FE Results are nearly matching. By considering these results the Lift equipment is safe for an efficient performance in an Industries.

REFERENCES

- [1] Raymond A. Kulwiec, Materials Handling Handbook (Michigan: American Society of Mechanical Engineers, International Material Management Society, Wiley, 1985).
- [2] John Vangle and Will Lynn for TURNTABLE ATTACHMENT Filed July 1, 1922.
- [3] Silva, F. B.; Barros, M. M. S. B. Av. Prof. Almeida Prado, trav. Universitária-São Paulo for process planning.
- [4] Meyers, F. E. (2005). Manufacturing Facilities Design and Material Handling. 3rd. Ed. Upper Saddle: Prentice Hall.
- [5] Assembly Automation and Product Design. Boothroyd, Marcell Dekker, Inc. 1992.
- [6] Product Design for Manufacture and Assembly G. Boothroyd and P. Dewhurst, Boothroyd Dewhurst, Inc. 1989
- [7] Design and Analysis of Manufacturing Systems Prof. Rajan Suri University of Wisconsin 1995
- [8] Product Design for Assembly: The Methodology Applied G. Lewis and H. Connelly
- [9] Product Design for Manufacture and Assembly, Geoffrey Boothroyd, Peter Dewhurst, Winston Knight, 2nd Edition, Marcel Dekker, New York
- [10] Computer-Aided Manufacturing, Second Edition, Tien-Chien chang, Richard A Wysk, and Hsu-Pin Wang. Pages 596 to 597. Prentice Hall 1998
- [11] Rehg, James A. & Kraebber, Henry W. (2005). Computer Integrated Manufacturing. (3rd Ed.) Prentice-Hall: Englewood Cliffs, N.J.
- [12] Kelley, M.R. and Brooks, H., The State of Computerized Automation in US Manufacturing, J.F. Kennedy School Of Government, Harvard University, October 1988.