

Modeling of Rotating Reference Frame Control of Transformerless Single Phase Grid Tie Inverter

Disha¹, Chaithra L², Suryanarayana K³, Dr. Nagesh Prabhu⁴,

Student, Department of Electrical and Electronics, NMAM Institute of Technology, Nitte, India¹

Senior Engineer, R&D, HEXMOTO Controls Pvt Ltd, Mysuru, India²

Associate Professor, Department of Electrical and Electronics, NMAM Institute of Technology, Nitte, India³

Professor, Department of Electrical and Electronics, NMAM Institute of Technology, Nitte, India⁴

ABSTRACT: Inverter plays major role in supplying harvested power from renewable energy sources to grid. The inverter should supply power to grid with high efficiency and power quality. In this system rotating reference frame control is used to supply real power to grid which having theoretically zero steady state error. Modified Unipolar Sinusoidal Pulse Width Modulation (MUSPWM) is used to increase the efficiency of the system.

KEYWORDS: Rotating reference frame, grid tie inverter, real power.

I. INTRODUCTION

Grid synchronization is a main factor to be considered to connect the power converters to the grid. This ensures the synchronized working of grid and the power converter. The grid voltage phase-angle is required to transform the grid variables from the stationary reference frame to rotating reference frame also known d-q reference frame, so that AC currents or voltages are regulated in terms of DC variables in the regulation which simplifies design of compensator. Transformerless single phase grid tie inverter have several advantages such as efficiency, low cost and small size. In this system current control scheme AC components are transformed into DC component, PI controller easily removes steady state error completely and provides infinite gain at fundamental frequency [1].

II. SYSTEM DESIGN

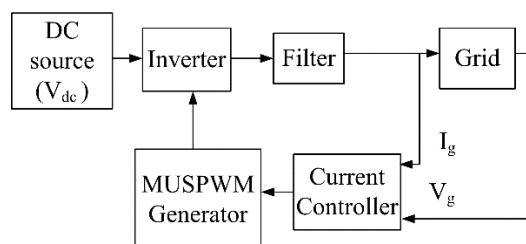

Figure 1.a: Block diagram single phase grid tie inverter system with current control

The proposed system block diagram is shown in Figure 1.a. The inverter current I_g and grid voltage V_g are fed back to current control. The rotating reference frame current control scheme produces the reference signal to MUSPWM which

International Journal of Innovative Research in Science, Engineering and Technology

(An ISO 3297: 2007 Certified Organization)

Vol. 5, Special Issue 9, May 2016

generates switching sequence for grid tie inverter. The DC bus voltage V_{dc} is constant. The single line diagram of grid tie inverter is shown in the Figure 1.b. This shows direction of the supply current I_g .

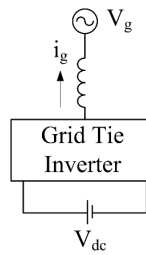

Figure 1.b: Single line diagram of real power supply

III. CURRENT CONTROL

Block diagram of rotating reference current control of transformerless single phase grid tie inverter system is shown in Figure 2. Here I_g is the current supplied to the grid, V_g is the grid voltage and V_{dc} is the constant DC bus voltage. PLL tracks the angle of the grid voltage to maintain power factor of 1. In this current control scheme V_g and I_g are represented as X . This signal X is transformed to X_α and X_β . Where X_α is X and X_β is leading X by 90° . X_α and X_β are the AC signals transformed to DC signal X_d and X_q using Park's transformation as given in (1).

$$\begin{bmatrix} X_d \\ X_q \end{bmatrix} = \begin{bmatrix} \cos(\theta) & \sin(\theta) \\ -\sin(\theta) & \cos(\theta) \end{bmatrix} \begin{bmatrix} X_\alpha \\ X_\beta \end{bmatrix} \tag{1}$$

This I_d and I_q are compared with the reference I_{dref} and I_{qref} . Where I_{dref} is the current reference to supply real power and I_{qref} is kept zero which contributes to reactive power supply. Then the error signals generated are compensated using PI controller. Decoupling is used to decouple the voltage which is cross coupled during Park's transformation. This decoupled signal D_d and D_q are transformed back to AC signal using inverse Park's transformation. V_α and V_β is obtained from the Eq. (2).

$$\begin{bmatrix} V_\alpha \\ V_\beta \end{bmatrix} = \begin{bmatrix} \cos(\omega t) & -\sin(\omega t) \\ \sin(\omega t) & \cos(\omega t) \end{bmatrix} \begin{bmatrix} D_d \\ D_q \end{bmatrix} \tag{2}$$

The V_α is the reference signal for MUSPWM switching generator which drives the inverter switches.

International Journal of Innovative Research in Science, Engineering and Technology

(An ISO 3297: 2007 Certified Organization)

Vol. 5, Special Issue 9, May 2016

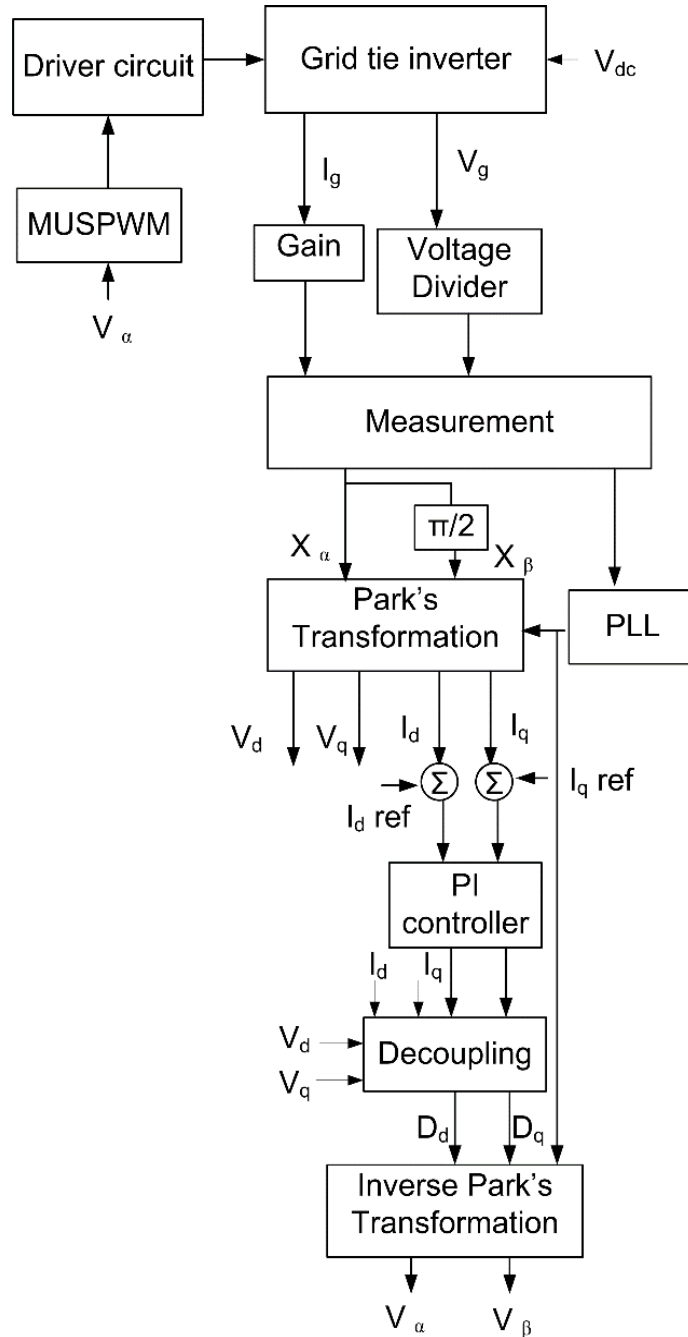

Figure 2: Block diagram of rotating reference current control single phase grid tie inverter system

International Journal of Innovative Research in Science, Engineering and Technology

(An ISO 3297: 2007 Certified Organization)

Vol. 5, Special Issue 9, May 2016

IV. SIMULATIONS RESULTS

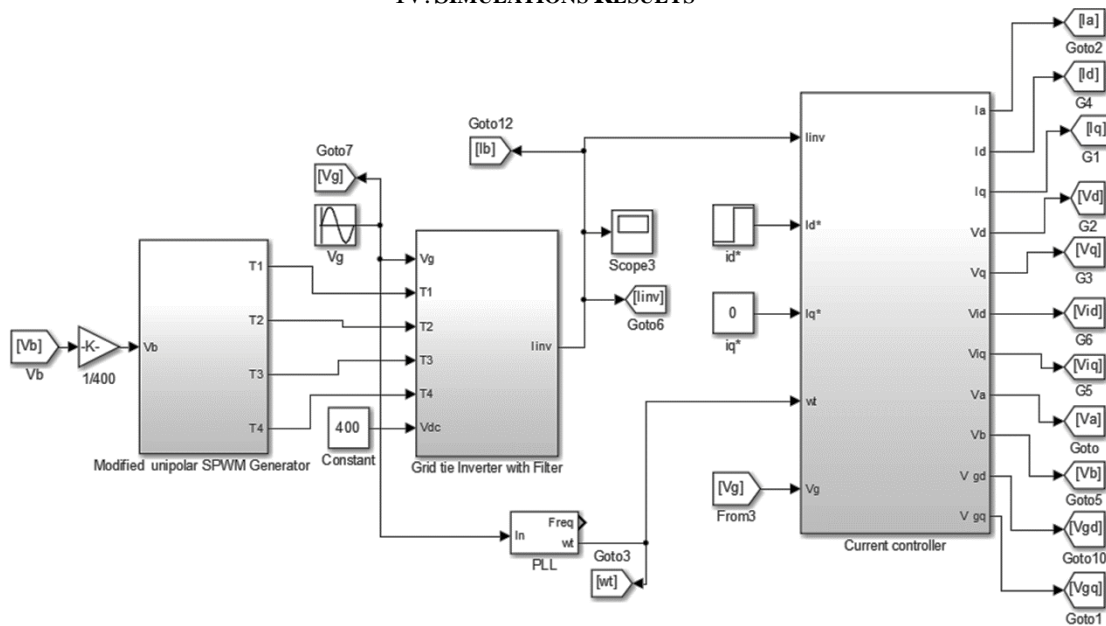

Figure 3: MATLAB Simulink model of system

MATLAB/Simulink model of grid tie inverter is shown in Figure 3. This model consists of MUSPWM, grid tie inverter with filter, and current controller blocks.

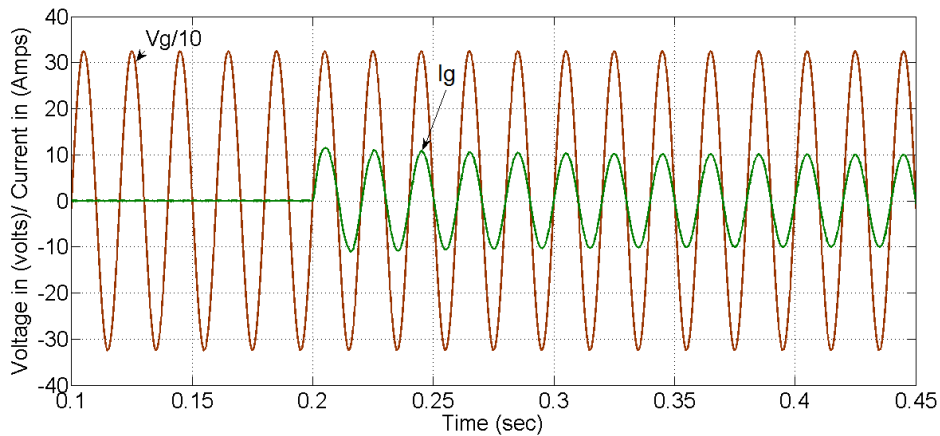

Figure 4: Current supplied to the grid I_g and grid voltage V_g

I_g is the current supplied to the grid which follows the angle of the grid voltage V_g to maintain power factor of 1. Reference current is increased from 0 to 10 A at 0.2s and response of I_g is shown in Figure 3. I_g current peak is decided by the reference current I_{gref} .

International Journal of Innovative Research in Science, Engineering and Technology

(An ISO 3297: 2007 Certified Organization)

Vol. 5, Special Issue 9, May 2016

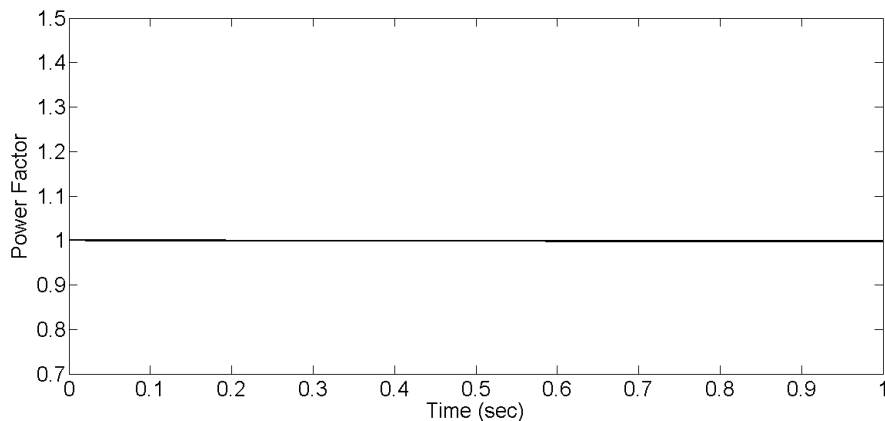

Figure 5: Power factor

The power factor output of the system is shown in Figure 5. The real power and reactive power step response is shown in Figure 6. Here only real power is supplied to the grid in steady state.

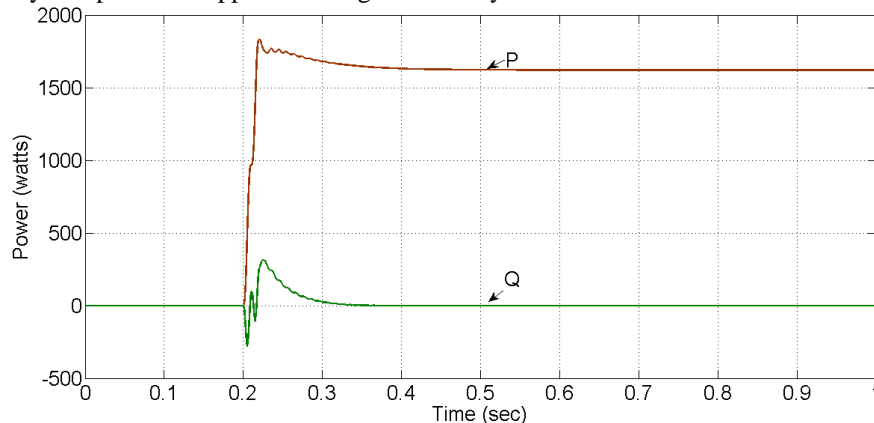

Figure 6: Real power (P) and Reactive power (Q)

V. CONCLUSION

Transformerless Single phase grid tie inverter with rotating frame current control scheme is simulated using MATLAB/Simulink model. This system is designed to supply real power to the grid efficiently.

ACKNOWLEDGMENT

Authors gratefully acknowledge the support received from HEXMOTO Controls. Pvt. Ltd, Mysuru, R&D Centre, Nitte, NMAM Institute of Technology, Nitte Education Trust and VTU, Belagavi in carrying out the research work.

REFERENCES

- [1] Remus Teodorescu, Marco Liserre and Pedro Rodríguez, "Grid Converters for Photovoltaic and Wind Power Systems", IEEE and John Wiley & Sons, Ltd, 2011.
- [2] Xiang dong Zong, "A Single Phase Grid Connected DC/AC Inverter with Reactive Power Control for Residential PV Application", Master's thesis, University of Toronto, 2011.
- [3] Zhigang Liang, Ales L., Xiaohu Zhou, Huang, A.Q., "Digital Controller Development for Grid-Tied Photovoltaic Inverter with Model Based Technique", Applied Power Electronics Conference and Exposition (APEC), Twenty-Fifth Annual IEEE, pp: 849 – 853, 2010.

International Journal of Innovative Research in Science, Engineering and Technology

(An ISO 3297: 2007 Certified Organization)

Vol. 5, Special Issue 9, May 2016

- [4] Richard Zhang, Mark Cardinal, Paul Szczesny and Mark Dame, "A Grid Simulator with Control of Single-phase Power Converter sin D-Q Rotating Frame", Power Electronics Specialists Conference, pesc 02. IEEE 33rd Annual, pp 1431 – 1436, 2002.
- [5] De Souza, K.C.A., dos Santos, W.M.,Martins, D.C., "A single-phase active power filter based in a two stages grid-connected PV system", Industrial Electronics, IECON '09. 35th Annual Conference of IEEE, pp.: 114 – 119, 2009.
- [6] Mohan, N., Undeland, T., Robbins, W., "Power electronics- Converters, Applications, and Design"– John Wiley & Sons, Inc. 1995.
- [7] Tajud i,din, M.F.N.Ghazali, N.H.Siong, T.C. "Modelling and simulation of modified unipolar PWM scheme on a single phase DC-AC converter using PSIM" ,Research and Development (SCORed), IEEE Student Conference on pp.: 328 – 331, 2009.