

Simulation and Implementation of Light Flickermeter

Roshani Supriya B N¹, Nayana P Shetty²

M.Tech Student, Department of Microelectronics and Control Systems, NMAM Institute of Technology, Udupi, India¹

Associate Professor, Department of Electrical and Electronics, NMAM Institute of Technology, Udupi, India²

ABSTRACT: The paper presents the analysis and implementation of light flickermeter. MATLAB simulink is used for the analysis purpose to measure the amount of flicker. ARM processor is used for hardware implementation. The main aim of light flickermeter is to eliminate the dc level and high frequency components. Thus quantified flicker obtained is nothing but the flicker of low frequency component sensed by the human eye. The modified flickermeter analogous to the Standard IEC flickermeter with some modification added.

KEYWORDS: Low pass Filter(LPF), High pass filter(HPF), Incandescent lamps(IL), Non-incandescent lamp(NIL)

I. INTRODUCTION

Flicker is the phenomenon of variation in the light intensity. This fluctuation changes continuously over time [1] causes headache, visual tiredness and loss of concentration in many individuals [2]. Flickermeter is a device used to measure the severity of flicker present in different lamp technologies [2]. Thus it helps the industrial and residential customers to choose the appropriate flicker free lamps suitable for the human eye. The proposed flickermeter is developed based on the standard IEC flickermeter using MATLAB simulink. ARM processor is used for practical implementation to check the severity of the flicker present.

II. SIMULATION

Flickering lamps are modeled at different variable intensities to give as input to modeled flickermeter using MATLAB simulink. This helps to show the advantage of proposed flickermeter over standard IEC flickermeter. IEC flickermeter can able to measure the flickering present only in incandescent lamps where as proposed one can compute for both incandescent and non-incandescent lamps [3]

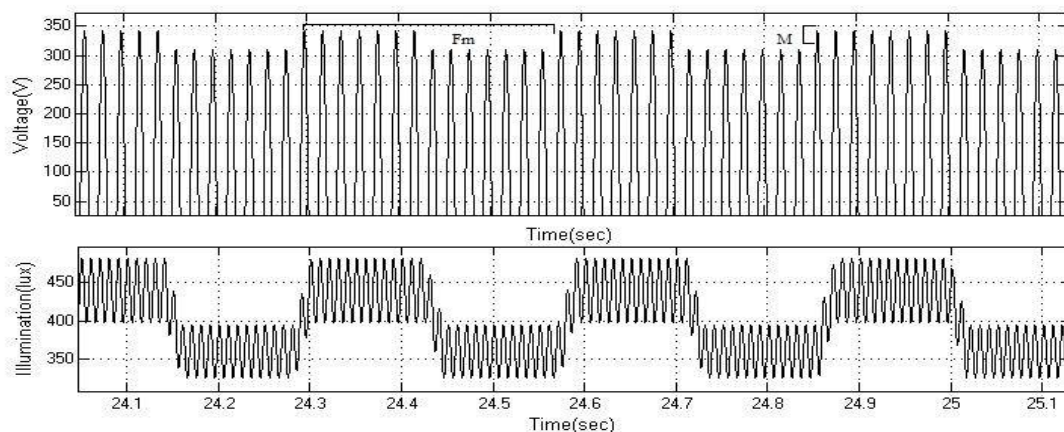

Fig.1: Fluctuated voltage and its illumination from 60Watts IL lamp

International Journal of Innovative Research in Science, Engineering and Technology

(An ISO 3297: 2007 Certified Organization)

Vol. 5, Special Issue 9, May 2016

A. Standard IEC Flickermeter

Voltage fluctuations in fundamental input power supply of 230 V and 50Hz causes flickering in lamps as shown in Figure1. Fluctuating frequency [Fm] and amplitude modulation [M] are the two important parameters responsible for flicker[1]. IEC flickermeter has the fluctuating voltage as the input from block 1 (figure 2). Digitalized and normalised voltage signal from block 1 under go some quadratic operations[6] to produce the illumination equal to incandescent lamps in block 2. High frequency and dc components are removed using LPF and HPF Filters in block 3. Block 4 is related to effect on brain memory. Statistical analysis is computed to check the sharpness of flicker.

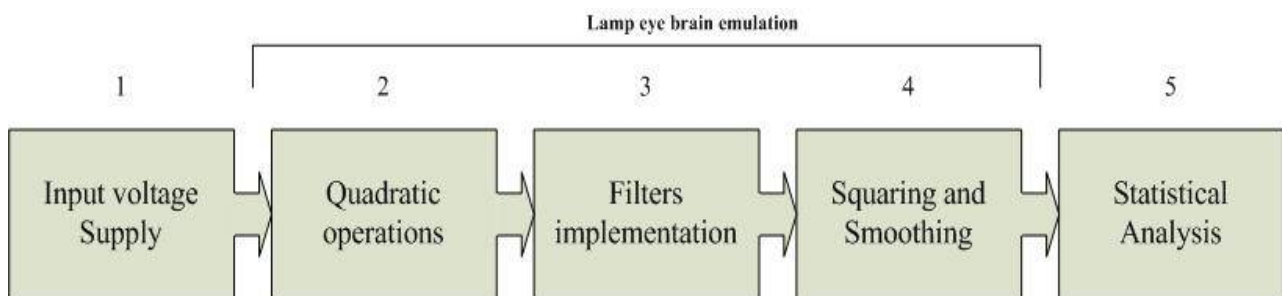

Fig.2: Standard IEC Flickermeter

B. Lamp Modeling

Model of an IL lamp is shown in figure 3 fluctuation frequency(Fm) 3.5Hz and amplitude modulation (M) 5% are considered in fundamental supply voltage shown in figure 1. With the known number of watts on the bulb, current and resistor values are calculated.

- 60watts of lamp requires 184mA and 1.7k ohm of current and resistance.
- $R = V/I$
- Power converted to lumens which is given by
- $\text{Illumination(Lm)} = \text{Power(W)} * \text{illumination per watt(Lm/W)}$
- Typically, 60W IL gives the lumens of 480 Lm
- Therefore 1 watt IL gives the lumens of 8 Lm/Watt
- Average of all these of lumens is given as input to the flickermeter

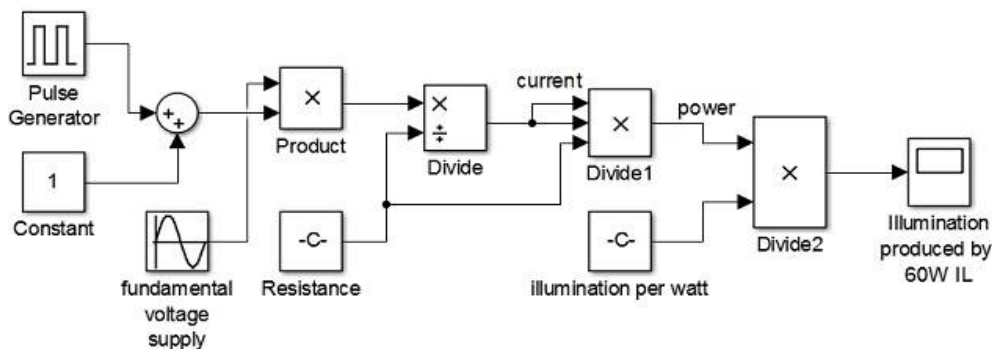

Fig.3 Model of IL lamp

C. Model of proposed Light Flickermeter

The figure 4 shows model of proposed flickermeter. The illumination is converted to voltage with the help of the sensor. Sensor modeling is done in subsystem by considering the characteristics of TEMT6000 (which is human eye sensitive sensor). Butterworth low pass filter of sixth order is used to ensure the linearity of the pass band signal[7]. The signal is digitalized using analog to digital converter under sampling rate and resolution of 2400Hz and 12bits respectively[1].

International Journal of Innovative Research in Science, Engineering and Technology

(An ISO 3297: 2007 Certified Organization)

Vol. 5, Special Issue 9, May 2016

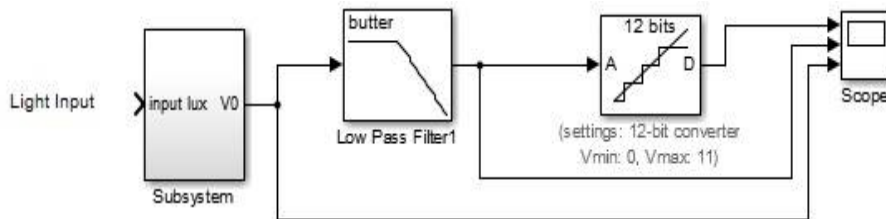

Fig. 4: Model of Proposed Flickermeter

HPF of 1st order and LPF of sixth order with the cutoff frequency of 0.05Hz and 42Hz is used to eliminate the dc level and high frequency component respectively. Another LPF of first order ensures smoothing of signal which is related to disturbance in the brain memory[5]. The output amplitude is adjusted by squaring the signal. Thus flicker obtained is the equal to the sharpness of flicker sensed by human eye.

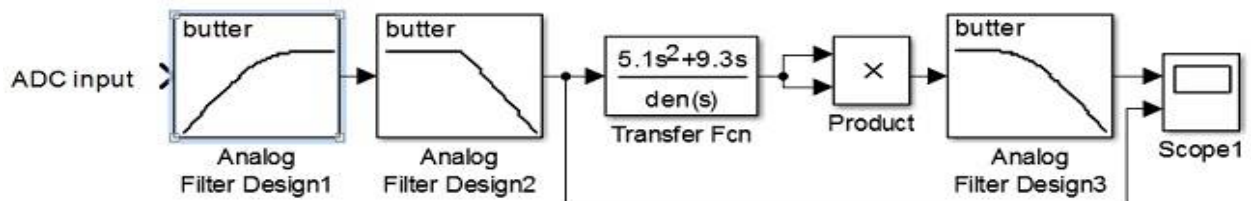

Fig. 5: Model of Proposed Flickermeter(continue)

1. Instantaneous flicker produced by IL OF 60W as shown in figure 6
 - a. Flicker from IL Lamp
 - b. Illumination produced from ADC
 - c. Instantaneous flicker sensed by human eye

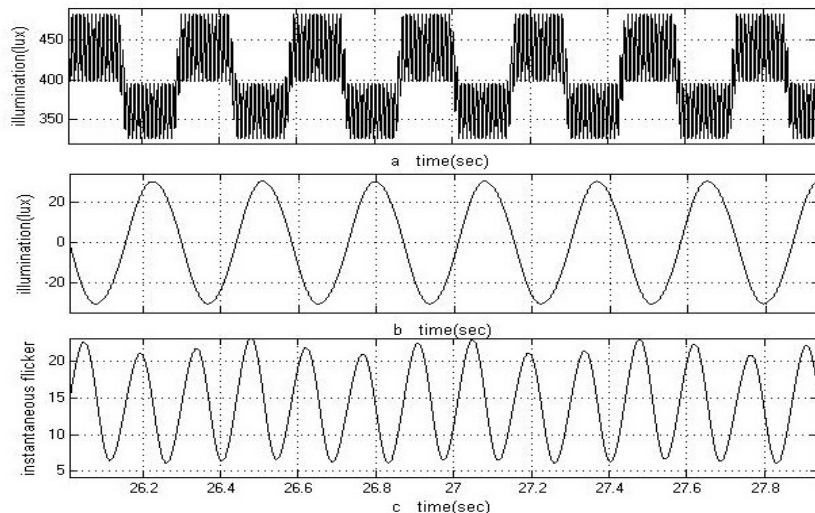

Fig. 6: Result from Incandescent lamp

International Journal of Innovative Research in Science, Engineering and Technology

(An ISO 3297: 2007 Certified Organization)

Vol. 5, Special Issue 9, May 2016

2. Instantaneous flicker produced by IL OF 60W as shown in figure 7
 - a. Flicker from IL Lamp
 - b. Illumination produced from ADC
 - c. Instantaneous flicker sensed by human eye

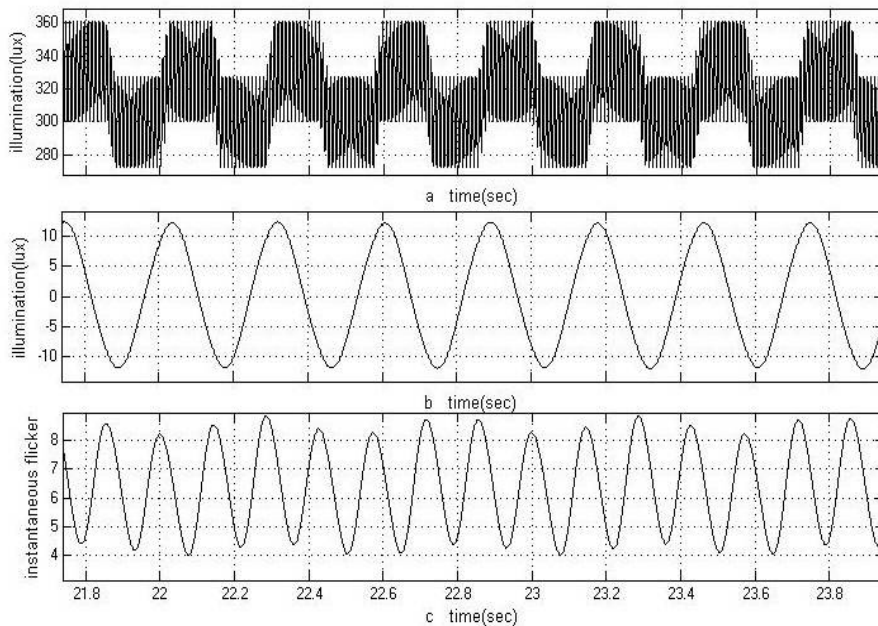

Fig. 7: Result from Non-Incandescent lamp

III. HARDWARE IMPLEMENTATION

Created light source of different intensity from block A shown in figure.9 is given to photo sensor in block B. Sensor convert fluctuating light to voltage. This voltage consist of dc level, high frequency component and flicker due to arc furnaces[2]. The main aim of block C is to eliminate this high frequency component and dc. Depending on the amount of flicker present in particular lamp, percentage of flicker will be calculated and displayed in block D.

A. Block A

The light source of 5V white LED bulb (D1) is used. Variable intensity of light source is created by adjusting the duty ratio of 555 timer output as shown in fig.8.

- Duty Ratio = $T_{on}/(T_{on}+T_{off})$
- $T_{on}=0.693 \times R1 \times C1$, $T_{off}=0.693 \times R2 \times C1$
- $R1=101K$ POT, $R2=101K$ POT

Duty ratio is adjusted using two pots R1 and R2 as shown in figure 8 and thus LED emits light of different flickering intensities.

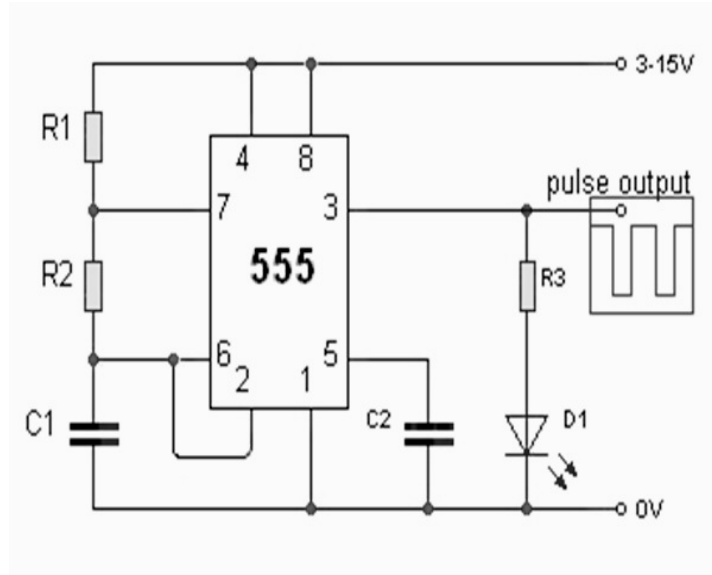

Fig.8: Block A-Equivalent diagram

B. Block B—TEMT6000 Photo sensor

The response of this sensor is similar to that of sensibility of human eye to the fluctuating light. Beside it offers low cost around 200INR. Appropriate frequency band is purpose of choosing this sensor. It consumes less amount of supply current. The timer response of this sensor is very fast and output voltage has excellent linearity v/s input light.

C. Block C and D—ARM Cortex-M3 processor

The signal from sensor is sampled in analog to digital converter using ARM Cortex-M3 LPC1768 microcontroller under the resolution of 2400 samples/sec beside it has good memory capacity with low cost. The sampled signal is normalized and it is compared with that of initial samples which gives error in the signal. Low pass filter of second order is implemented to remove high frequency component in error signal. Percentage of flicker is obtained is given by

$$\text{Percentage of flicker} = (\text{error signal} \times 100) / \text{Normalized value}$$

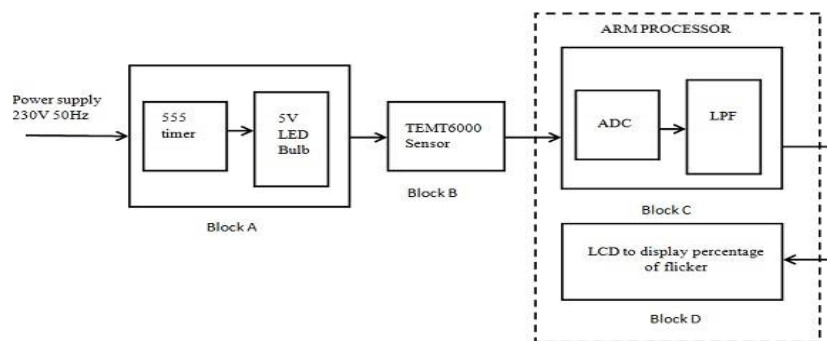

Fig.9: Proposed Flickermeter

D. Prototype Results

The figure.10 shows the display of percentage of flicker in LCD when LED emits low frequency flicker using 555 timer. This flicker is invisible but effects the human eye when subjected to long duration.

International Journal of Innovative Research in Science, Engineering and Technology

(An ISO 3297: 2007 Certified Organization)

Vol. 5, Special Issue 9, May 2016

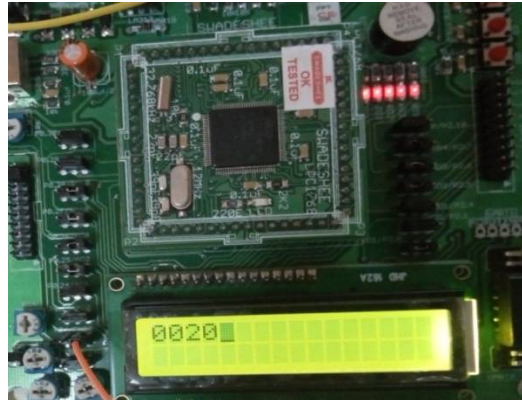

Fig.10: Percentage of flicker at better quality of LED

The figure.11 shows the display of percentage of flicker in LCD when LED emits high frequency flicker using 555 timer. This flicker is visible to human eye even when subjected to short duration.



Fig.11: Percentage of flicker at low quality of LED

IV. CONCLUSION

The Proposed flickermeter modeled using MATLAB simulink overcomes the drawback of IEC Flickermeter. It found to produce satisfactory results not only for incandecent lamps but also for non-incandecent lamps. Measuring of flicker using ARM processor is cost effective with lesser power consumption. Thus helps the industrial customers to choose the appropriate bulbs suitable for human eye.

ACKNOWLEDGMENT

I would like to thank Nayana P Shetty and Vishnu Prasad V Bhat for internal and external guidance of project

REFERENCES

- [1] Guilherme Piazentini Colnago, Jose Rubens Macedo, Jose Luiz de Freitas Vieira, Dept. "Electrical Engineering Implementation of a light Flickermeter in a low cost embedded system" IET Science, Measurement & Technology, Vol.9, pp.522–531, 2015
- [2] Wilkins, A.J., Nimmo-Smith, I., Slater, A.I., Bedocs, L. "Fluorescent lighting, headaches and eyestrain", Light. Res. Technol., Vol.21, pp.11–18, 1989.
- [3] Bharat, B. 'Arc furnace flicker measurements and control', IEEE Trans. Power Deliv., Vol.8, pp.400–410, 1993.

International Journal of Innovative Research in Science, Engineering and Technology

(An ISO 3297: 2007 Certified Organization)

Vol. 5, Special Issue 9, May 2016

- [4] Wilkins, A., Veitch, J., Lehman, B. "LED lighting flicker and potential health concerns: IEEE standard PAR1789 update", Atlanta, USA, Vol.21, pp. 171–178, September 2010.
- [5] Wang, C.S., Devaney, M.J. "Incandescent lamp flicker mitigation and measurement", IEEE Trans. Instrum. Meas., Vol.53, pp. 1028–1034, 2004.
- [6] Gallo, D., Landi, C., Langella, R., Testa, A. "On the use of the flickermeter to limit low-frequency interharmonic voltages", IEEE Trans. Power Deliv., Vol.23, pp. 1720–1727, 2008.
- [7] Emanuel, A.E., Peretto, L.: 'The response of fluorescent lamp with magnetic ballast to voltage distortion', IEEE Trans. Power Deliv., Vol.12, pp. 289–295, 1997.