

Tracking Error Reduction of APA230L Piezoelectric Actuator using Feed forward- Feedback Control System

Sushith K ¹, Md Abdul Raheman ², Muralidhara ³, Rathnamala Rao ⁴

PG Scholar, Department of Electrical and Electronics Engineering, NMAMIT, Nitte, Karkala, Karnataka, India¹

Asst. Professor, Department of Electrical and Electronics Engineering, NMAMIT, Nitte, Karkala, Karnataka, India²

Professor, Department of Mechanical Engineering, NMAMIT, Nitte, Karkala, Karnataka, India³

Asst. Professor, Department of Electronics and Communication Engineering, NITK, Surathkal, Karnataka, India⁴

ABSTRACT: The piezoelectric actuator is an electromechanical device which can transduce energy between electrical and mechanical. Piezoelectric actuator is a nonlinear device because of hysteresis. The tracking control of a nonlinear system is difficult. Many methods have been proposed to compensate the hysteresis effect in the piezoelectric actuator. In this paper, Bouc-wen model is used to study the behaviour of the hysteresis effect. Inverse Bouc-wen model (feed-forward model) is used to compensate the hysteresis effect in actuator. Feedforward-feedback control system is utilized to compensate the hysteresis and to improve the tracking accuracy. In this paper, feedforward and feedforward-feedback controller of APA230L piezoelectric actuator were presented to control the output displacement. Simulation and experimental tests were conducted to verify of the proposed controller.

KEYWORDS: Bouc-Wen model, Inverse Bouc-Wen model, Feedforward controller, Feedforward-feedback controller, APA230L Piezoelectric actuator.

I. INTRODUCTION

Piezoelectricity is the fundamental process of electromechanical energy conversion. In this phenomenon certain material gives electrical energy when a mechanical stress is applied and vice-versa. A piezoelectricity is exhibited by certain naturally occurring crystalline materials such as quartz and tourmaline. Some piezoelectric crystals are produced artificially such as Rochelle salt, ammonium dehydrogenate phosphate. Piezoelectric actuator is a set of electromechanical device. It is widely used in precision positioning amplification [4]. The key characteristics of a piezoelectric actuator are high stiffness, fast frequency response and nanometer resolution in displacement. However there are few drawbacks of piezoelectric actuator. These are hysteresis and creep. Creep describes the changes in the displacement over the time with an unchanged drive voltage. Hysteresis is major drawback in a piezoelectric actuator. When voltage is applied to the piezoelectric actuator the output displacement is not only dependent on the present input, but also depends on past input. Many models have been proposed to describe the behaviour of hysteresis such as Bouc-wen, Maxwell's Slip, Prandtl-Ishlinskii (P-I) model. In this paper hysteresis behaviour is described by Bouc-wen model. Inverse Bouc-wen model (Feedforward model) is used to compensate the hysteresis effect in the piezoelectric actuator [5]. Under Feedforward method piezoelectric actuator will produce 8 to 10% error. As the frequency of input signal is increases, the error also increases [6]. Combination of Feedforward and feedback control system reduces the tracking error to minimum percent with high accuracy and steady state error. [6].

In this paper, tracking control of APA230L piezoelectric actuator is discussed by feedforward and feedforward-feedback control system. . Feedforward & Feedback control system for APA230L is experimentally tested in real time using dSPACE DS1104 interfaced with Simulink

International Journal of Innovative Research in Science, Engineering and Technology

(An ISO 3297: 2007 Certified Organization)

Vol. 5, Special Issue 9, May 2016

II. MODELLING OF PIEZOELECTRIC ACTUATOR

FORWARD MODEL OF APA230L PIEZOELECTRIC ACTUATOR

Piezoelectric actuator is a nonlinear system because of hysteresis behaviour. When the voltage is applied to the piezoelectric actuator, the output displacement is not only dependent on the present input but also depends on past input. Bouc-wen model is a simple model and can match the behaviour of a wide class of hysteresis systems [1]. In this paper, Bouc-wen model describing the hysteresis nonlinearities of a piezoelectric actuator is used. APA230L piezoelectric actuator by a nonlinearity hysteresis equation as

$$m\ddot{x} + b\dot{x} + kx = k(d\dot{u} - h) - 3k_s x \quad (1)$$

$$\dot{h} = \alpha d \dot{u} - \beta |\dot{u}| h - \gamma \dot{u} |h| \quad (2)$$

Where ‘u’ stands for applied input voltage of APA230L piezoelectric actuator

‘x’ represents the displacement of APA230L piezoelectric actuator

‘b’, ‘m’, and ‘k’ are the damping, mass and effective mechanical stiffness of the piezoelectric actuator

‘d’ is effective piezoelectric coefficient

‘β’, ‘γ’ and ‘α’ are parameters of the hysteretic loop’s shape and magnitude

‘h’ indicates the variable obtained from the hysteretic nonlinear dynamics.

‘Ks’ is stiffness of the APA230L in N/μm

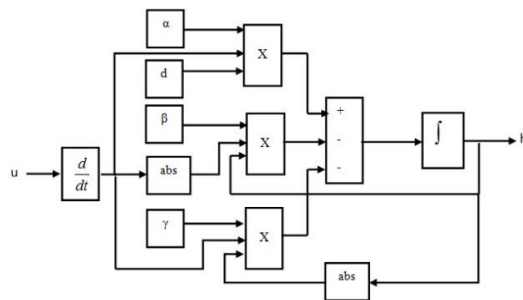

Figure 1: Bouc-wen model

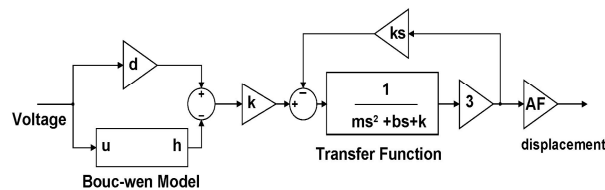

Figure 2: Forward model of APA230L piezoelectric actuator

Figure 1 shows Bouc-wen Hysteresis model designed by using equation 2. Simulink block diagram of forward actuator model for APA230L piezoelectric actuator is designed using equation 1 and designed actuator model is as shown in figure 2. AF represents the amplification factor of APA230L piezoelectric actuator.

INVERSE BOUC-WEN MODEL FOR APA230L PIEZOELECTRIC ACTUATOR

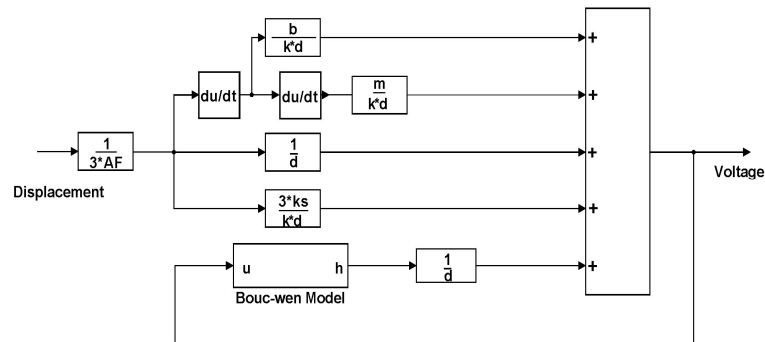

Figure 3: Inverse Bouc-wen model for hysteresis compensation of APA230L piezoelectric actuator

As discussed in the previous section, forward actuator model describes how an actuator responds to the actuating signal. Hysteresis will be present in the forward actuator model. In this paper, Inverse Bouc-wen model is presented for the purpose of compensating the hysteresis effect and it calculates the actuating voltage for given displacement. Figure 3 shows the APA230L piezoelectric actuator’s inverse model and can be designed by using equation 3 and expressed as

$$u = \left(\frac{m}{k \times d}\right) \dot{x}^2 + \left(\frac{b}{k \times d}\right) \dot{x} + \left(\frac{1}{d} + \frac{3k_s}{k \times d}\right) x - \left(\frac{h}{d}\right) \quad (3)$$

III. CONTROL METHODS FOR PIEZOELECTRIC ACTUATOR

FEED FORWARD CONTROL SYSTEM FOR APA230L PIEZOELECTRIC ACTUATOR

Feedforward control system consists of inverse Bouc-wen model to eliminate the hysteresis in piezoelectric actuator. Figure 4 shows Simulink block diagram of open loop control system for APA230L piezoelectric actuator. The desired displacement signal is given as input to the inverse Bouc-wen model, which generates the voltage to drive the piezoelectric actuator. The Actuator will produce the displacement as per the voltage applied to it. Finally this model describes the relationship between desired displacement and actual displacement.

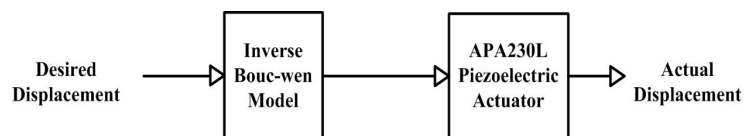

Figure 4: Feedforward control system for APA230L piezoelectric actuator

FEED FORWARD-FEEDBACK CONTROL SYSTEM FOR APA230L PIEZOELECTRIC ACTUATOR

To eliminate the nonlinear hysteresis effect, it is necessary to design a feed forward controller to cancel the nonlinear hysteric behaviours and improve the open loop control accuracy [1]. Figure 5 shows the block diagram of the feedforward-feedback control system. It is composed inverse Bouc-wen Feedforward control loop and a Controller loop. Generally PI controller is used for feedback controller. The desired displacement is taken as reference signal and it is applied to the inverse Bouc-wen model. Inverse Bouc-wen model produces the voltage which is given to the APA230L actuator. APA230L actuator will produces actual displacement. In the feedback loop, the desired displacement is compared to actual displacement and generated error signal is transferred to PI controller to reduce the error signal

International Journal of Innovative Research in Science, Engineering and Technology

(An ISO 3297: 2007 Certified Organization)

Vol. 5, Special Issue 9, May 2016

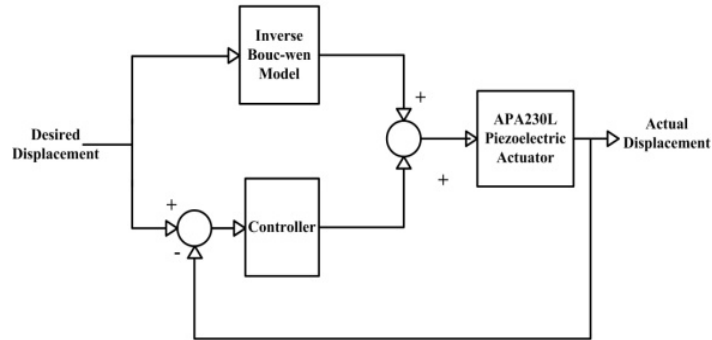

Figure 5: Block diagram of the feedforward-feedback control system for APA230L Piezoelectric Actuator

IV. PARAMETER ESTIMATION FOR APA230L PIEZOELECTRIC ACTUATOR

The parameters of the Bouc-wen model were estimated using least square method in Matlab/Simulink. To perform this experiment 0 to 150V, 1Hz sinusoidal input voltage was applied to MLA10x10x20 piezoelectric actuator that produces the displacement. Using obtained values of voltage and displacement, the unknown parameters of Bouc-wen model are estimated using parameter estimation tool in Matlab/Simulink. Later these parameters values were modified for APA230L piezoelectric actuator [6], which is shown in Table 1.

Table 1: Parameters Values of APA230L Piezoelectric Actuator for Bouc-Wen model [6]

Sl. No.	Parameters	Values	Unit
1	d	1.4310e-07	m/V
2	α	0.2220	-
3	β	0.0150	V^{-1}
4	γ	0.0045	V^{-1}
5	m	0.0150	Kg
6	b	150	Ns/m
7	k	200000000	N/M
8	k_s	7089000	N/M

V. RESULT AND DISCUSSION

SIMULATION RESULTS OF APA230L PIEZOELECTRIC ACTUATOR

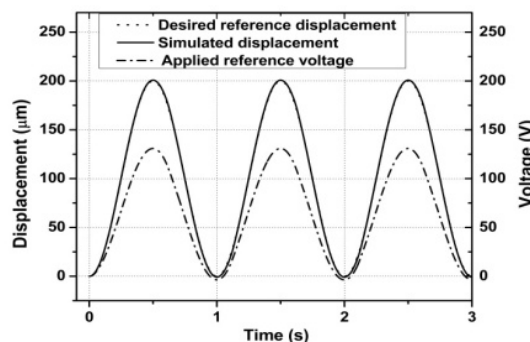

Figure 6: Simulation results of feedforward control system for APA230L piezoelectric actuator

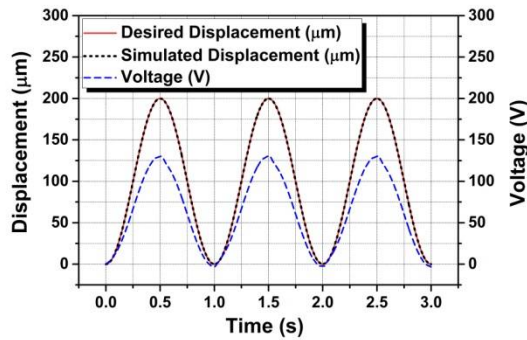

Figure 7: Simulation results of Feedforward-feedback control system for APA230L piezoelectric actuator

Displacement tracking of APA230L for 1Hz frequency with a sinusoidal input of 200µm using feedforward control system is as shown in Figure 6. Using feedforward model, the hysteresis is reduced from 6µm to 0.5µm and the error for the position tracking is 1.8% at steady state condition as shown in figure6. The block diagram of feedforward-feedback controller is shown in figure 5. In this simulation, PI controller is used as feedback controller to reduce the desired tracking error. Trust region reflective nonlinear least square method was used to make the nonlinear actuator model into a linear actuator model. The gradient decent SISO tool method in Matlab was used to tune the parameter of PI controller. The obtained gain values of PI controller are $K_p = 61.79e6$ & $K_i = 3.2185e12$ and desired Tracking error of the system was found $10e-15\mu\text{m}$ from the Figure 7.

EXPERIMENTAL RESULTS OF APA230L PIEZOELECTRIC ACTUATOR

The figure 8 shows block diagram of experiment set up model for APA230L piezoelectric actuator. The experimental set up model for APA230L piezoelectric actuator is shown in figure 9. dSPACE DS1104 is directly interfaced with Simulink model and controlled through dSPACE CONTROL DESK software. Usually in real time operating the Simulink model is interfaced with dSPACE1104. The generated output voltage from dSPACE1104 is given to the linear amplifier LA75. Linear amplifier amplifies the input signal at the gain of 20 and output of LA75 is connected to APA230L piezoelectric actuator. Opto laser sensor measures the displacement of APA230L piezoelectric actuator and sensors output is given back to the dSPACE1104.

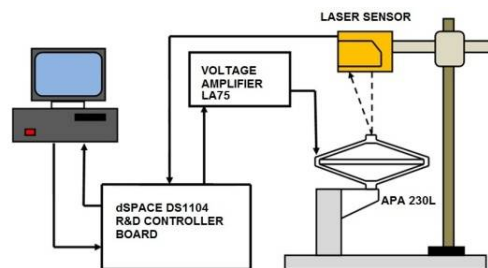

Figure 8: Block diagram of Experimental Set up model for APA230L Piezoelectric actuator

International Journal of Innovative Research in Science, Engineering and Technology

(An ISO 3297: 2007 Certified Organization)

Vol. 5, Special Issue 9, May 2016

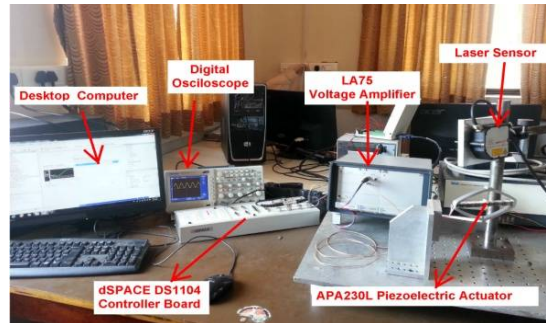

Figure 9: Experimental set up model for APA230L Piezoelectric actuator

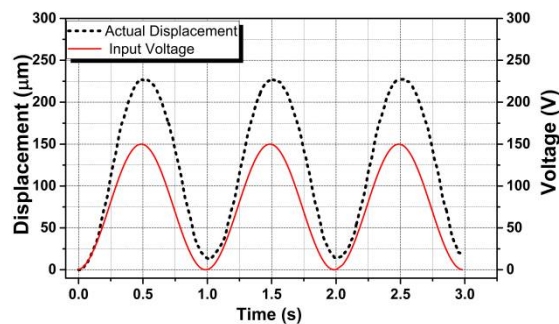

Figure 10: Plot of input voltage and output displacement of APA230L without hysteresis compensation

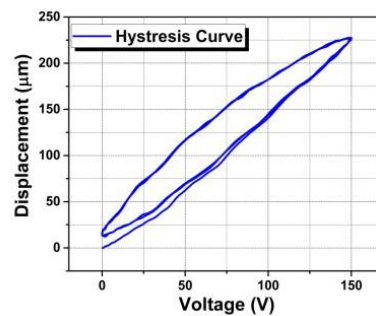

Figure 11: Hysteresis curve of APA230L

The experiment is conducted at 1Hz frequency by applying a sinusoidal signal of 0-150 V to APA230L piezoelectric actuator .The Maximum displacement obtained is 230 μm . The Figure 10 shows experimental results of displacement & input voltage with respect to time. Figure 11 shows plot of Hysteresis Curve between input voltage and output displacement without compensation. As seen from figure 11, when input voltage increases from 0 to 150V, the out displacement also increases from 0 to 230 μm . Later voltage starts decreasing from 150 to 0V, the output displacement also starts decreasing but does not reaches to zero when input voltage is zero. The hysteresis is typically in the order of 10% as observed from the Figure 11.

The Figure 12 shows experimental result of open loop control system for 1Hz frequency with a sinusoidal input of 200 μm . The laser displacement sensor records the displacement of the APA230L piezoelectric actuator and sends data back to the dSPACE. Open loop control system tracks the displacement with an error of 3.3% for 1Hz frequency. The tracking response of the Feedforward controller has the maximum tracking error of 7 to 9 μm . The hysteresis is reduced from 8 μm to 2 μm as shown in Figure 13.

International Journal of Innovative Research in Science, Engineering and Technology

(An ISO 3297: 2007 Certified Organization)

Vol. 5, Special Issue 9, May 2016

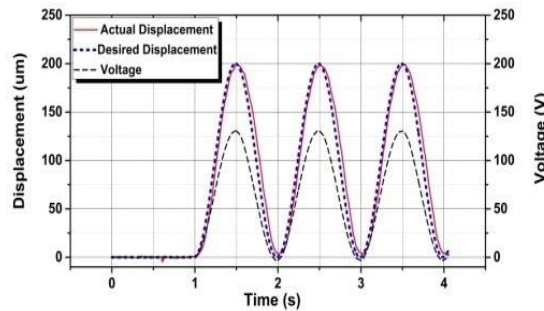

Figure 12: Experimental result of open loop control system for APA230L piezoelectric actuator

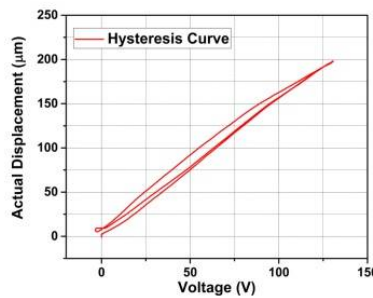

Figure 13: Compensated Hysteresis curve of APA230L using Feedforward control

The Figure 14 shows experimental results of Feedforward-feedback control system for 1Hz frequency with a sinusoidal input of 200µm. In feedforward-feedback control system, PI controller is used for reducing the tracking error and to improve the accuracy of the system. PI controller gain values are found by trial & error method. The gain value of PI controller are obtained as $K_p = 8195$ & $K_i = 180$ which tracks the displacement of APA230L with an error of 2.02% for 1Hz frequency.

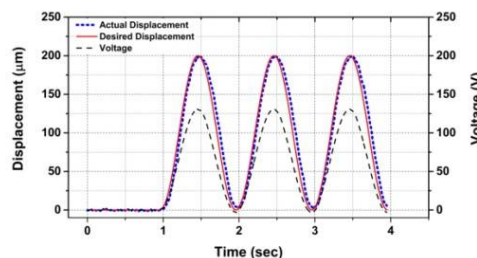

Figure 14: Experimental result of Feedforward-Feedback control system for APA230L piezoelectric actuator

VI. CONCLUSION

In this paper, the performance of classical Bouc-wen model was evaluated for 1 Hz frequency. The inertial-dependent Bouc-wen model captures the hysteresis at 150V input amplitude and 1Hz input frequency. The design and simulation study of open loop and feedforward-feedback control system to reduce the hysteresis and tracking error of

International Journal of Innovative Research in Science, Engineering and Technology

(An ISO 3297: 2007 Certified Organization)

Vol. 5, Special Issue 9, May 2016

the APA230L piezoelectric Actuator is performed. The PI controller was used as feedback controller to reduce the tracking error. The proposed method has better tracking performance and higher position accuracy for 1Hz frequency.

REFERENCES

- [1] Jin-Wei Lian, Hung-Yi Chen “Feedforward and Feedback Control for Piezoelectric Actuated Systems using Inverse Prandtl-Ishlinskii Model and Particle Swarm Optimization” Proceedings of the 2014 IEEE International Conference on Advanced Mechatronic Systems, August 2014, Kumamoto.
- [2] <http://www.aurelienr.com/electronique/piezo/piezo.pdf>
- [3] Sun Lining, Ru. Chinghai, RongWeibin, Chen Liguog and Kong Minxiu “Tracking control of piezoelectric actuator based on a new mathematical model” Robot Research Institute, Harbin Institute of 9 August 2004.
- [4] Neil Kuyvenhoven “PID Tuning Methods An Automatic PID Tuning Study with MathCad “Calvin College ENGR. 315 December 19, 2002
Optimized PID tracking controller for piezoelectric actuator model” A. M. M. Youssef, Aircraft Electrical Equipment,, Military Technical college(MTC), Cairo 11787, Egypt.
- [5] Mokshitha, Dr. Muralidhara, Dr. Rathnamala Rao “Investigations on the displacement control of APA230L piezoelectric actuator”. International conference on emerging trends in engineering (ICETE-2015) 8th _9th 2015 NMAMIT Nitte
- [6] Micky Rakotondrabe, Philippe Lutz “Micky Rakotondrabe, Cédric Clévy and Philippe Lutz. “Complete open loop control of hysteretic, creeped” and oscillating piezoelectric cantilevers” Automation Science and Engineering, IEEE Transactions on (Volume: 7, Issue: 3), October 2009.