

Design, Analysis and Testing of Quadratic Arm Flexurally Amplified Piezoactuator

Sandesh Nayak¹, Muralidhara², Rathnamala Rao³Department of Mechanical Engineering, NMAM Institute of Technology, Nitte, Udupi, Karnataka, India^{1,2}Department of Electronics and Communication Engineering, NITK, Surathkal, Mangaluru, Karnataka, India³

ABSTRACT: Design of flexural amplifier for the pumping diaphragm actuator and for the valve diaphragm actuator incorporated in the piezohydraulic pump is done. Pumping diaphragm actuator consists of six piezostack actuators each having a dimension of 10*10*20mm and valve diaphragm actuator consists of a single piezostack of dimension 7*7*50mm. The amplifiers are analysed for its stiffness and the amplification factor using ANSYS analysis software. Also modal analysis is performed to determine the natural frequency. Simulations are performed to determine the displacement of both the actuators. Experiments are carried out to determine the stiffness and resonant frequency, and the results were in good agreement with the ANSYS results.

KEYWORDS: Flexural amplifier, pumping diaphragm actuator, valve diaphragm actuator and piezostack.

I. INTRODUCTION

A hydraulic pump is a device that converts mechanical power into hydraulic energy. The pump operates by creating vacuum at the pump inlet which forces the fluid to enter the inlet and delivers it to the outlet by performing suitable mechanical action [1]. Piezoelectric actuators convert electrical signals into precisely controlled physical displacement. Piezoactuators are one of the most popular electro-mechanical devices that find variety of applications in industrial devices that require precision control [4]. This precise control of movement afforded by the piezoelectric actuator can be used to finely adjust machining tools, lenses, mirrors or other equipment. These actuators have advantages such as high resolution, fast response, higher positioning accuracy, high stability, etc. Flexurally amplified piezoelectric actuators are the specifically designed actuators that uses piezoelectric stack actuators as the active material. These actuators make use of direct amplification mechanism involving a diamond shaped structure whose frame is symmetrical in nature. These actuators can produce a displacement amplification from 2 to 20 and have a good mechanical efficiency.

In this paper an active valve piezohydraulic pump with piezoelectric actuators is designed. One is pumping diaphragm actuator having six piezoelectric stack actuators and another is valve diaphragm actuator made up of a single stack. Suitable analysis is performed in the ANSYS analysis software and also the simulations are performed to determine the piezoactuator displacement.

II. DESIGN OF PIEZOHYDRAULIC PUMP

The Design of active valve high pressure piezohydraulic pump is as shown in the figure 1 below. The top of pumping diaphragm actuator is fixed to the mid support and the other side is fixed to the lift base. Design basically consists of three diaphragms, one is the pumping diaphragm and other two are the valve diaphragms. The pumping diaphragm is bolted to the pumping chamber and is actuated using pumping diaphragm actuator using a lifting rod. The inlet and outlet valves are provided with active control. An amplified piezoelectric actuator for the piezostack of dimension 7*7*50mm is designed for the valve diaphragm actuation. When the voltage is applied to the piezostack, the amplified piezoelectric actuator produces displacement. The displacement produced by the pumping diaphragm actuator causes the movement of lifting rod which in turn causes the slotted pumping diaphragm to deform creating vacuum and pressure alternatively. Due to the vacuum fluid flows to the pumping chamber through inlet valve and due to the pressure fluid flows from pumping chamber to the outlet. Simultaneously the valves are to be controlled. Outlet valve

International Journal of Innovative Research in Science, Engineering and Technology

(An ISO 3297: 2007 Certified Organization)

Vol. 5, Special Issue 9, May 2016

opens as the pumping diaphragm is actuated. At extreme deformed position of the pumping diaphragm, the inlet valve opens and outlet valve closes, and as the pumping diaphragm regains its position the fluid flows through the inlet valve. As the pumping diaphragm regains its position completely, outlet valve opens and inlet valve closes.

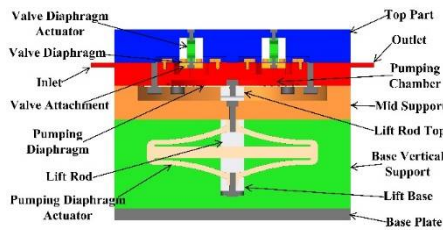

Figure 1: Cut sectional view of piezohydraulic pump

Design of pumping diaphragm actuator

The material selected for the flexural amplifier of the actuators is spring steel having properties: Young's Modulus = 210Gpa, Density = 7500Kg/m³ and Poisson's ratio = 0.3. The isometric view of flexural amplifier for pumping diaphragm actuator is as shown in the figure 2 below. The flexural amplifier designed is of 55mm in height and 145mm in width. Considering the stack cross section, the thickness of the amplifier is decided to be 10mm. The dimensions of the flexural amplifier are decided on the basis of the stiffness required. Force displacement analysis of the flexural amplifier is carried out to determine the stiffness and amplification factor.

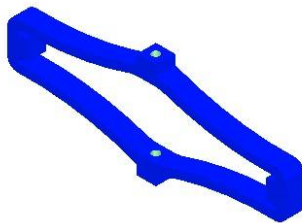

Figure 2: Pumping diaphragm flexural amplifier



Figure 3: Valve diaphragm flexural amplifier

Design of valve diaphragm actuator

The flexural amplifier designed for the valve actuator is as shown in the figure 3 above, having a height of 21mm and 60.06mm in width. Considering the thickness of stack, the thickness of the amplifier is kept to be 7mm.

III. RESULTS AND DISCUSSION

Load versus displacement analysis is performed in ANSYS analysis software for the flexural amplifiers of the actuators to determine their respective stiffness values. The slope of the plot obtained with load versus displacement gives the stiffness value.

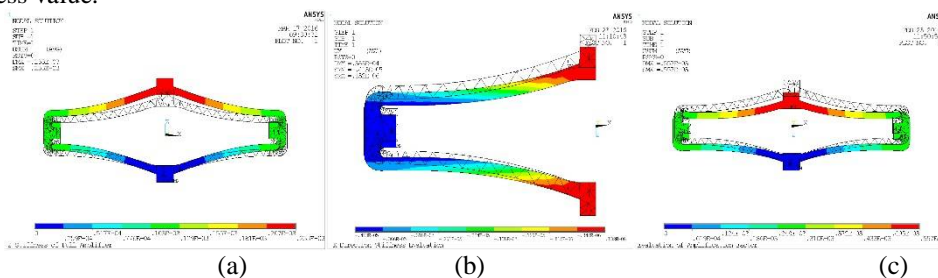

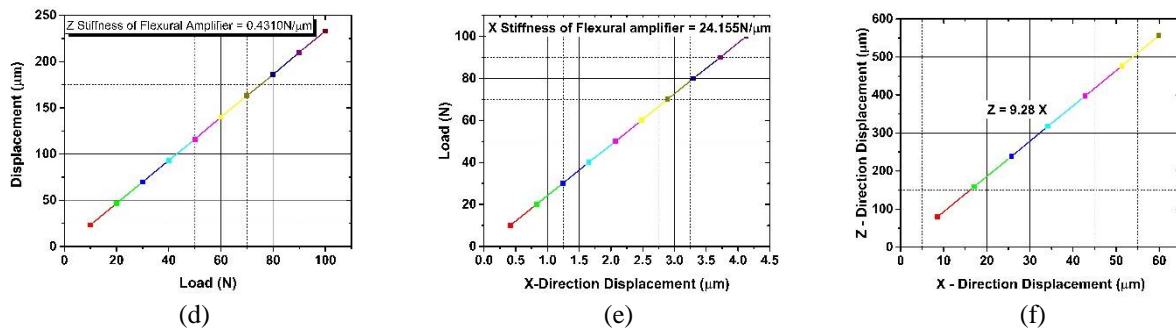

Figure 4: Stiffness and amplification factor evaluation of pumping diaphragm actuator

The z-direction stiffness analysis performed for the flexural amplifier of pumping diaphragm actuator, the lower end is completely fixed and load is applied at the upper end vertically upwards. For the x-direction stiffness evaluation lower end is completely fixed, upper end is left free only in z direction and load is applied in x direction. For the evaluation of amplification factor, lower end is completely fixed and load is applied in x direction acting away from the centre. The analysis resulted a stiffness value of 0.4310N/μm in Z-direction and 24.155N/μm in X-direction with an amplification factor of 9.28 as shown in the figure 4 above.

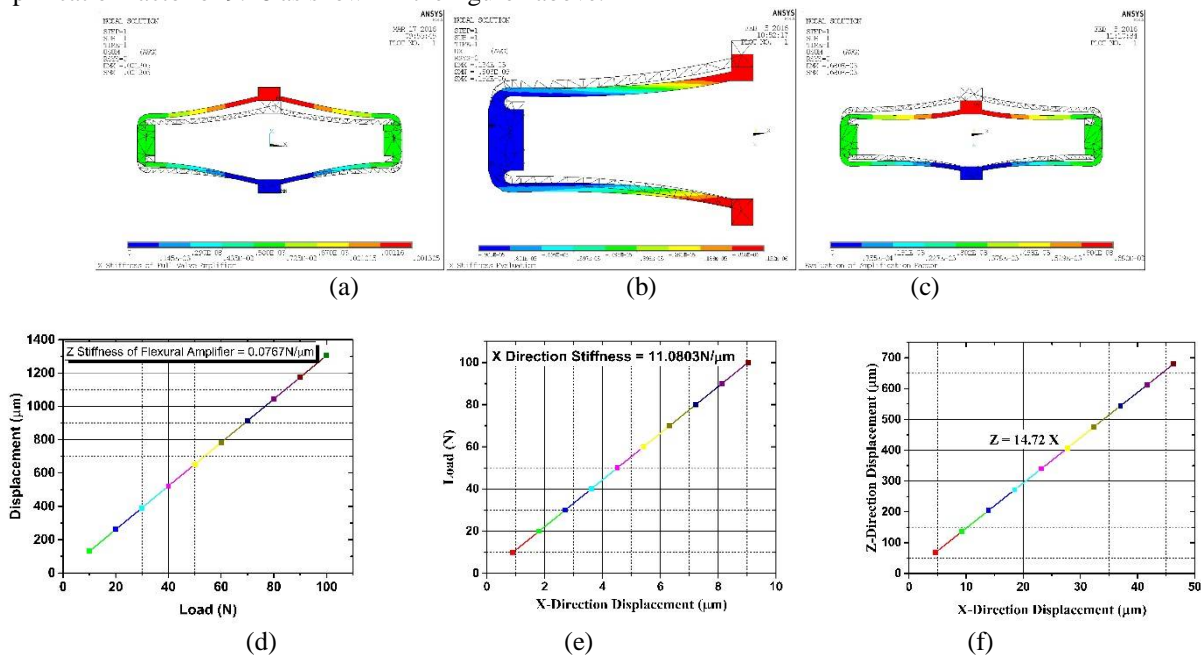

Figure 5: Stiffness and amplification factor evaluation of valve diaphragm actuator

Similar analysis is performed for the flexural amplifier of valve diaphragm actuator. The analysis resulted in a stiffness value of 0.0767N/μm in Z-direction and 11.0803N/μm in X-direction with an amplification factor of 14.72 as shown in the figure 5 above.

Modal analysis is the study of analysing dynamic response of structures under vibrational excitation. Modal analysis is performed for the pumping diaphragm actuator to determine resonance frequency values for the safe operation of the piezohydraulic pump. The results obtained from the modal analysis are as shown in the table 1 below.

International Journal of Innovative Research in Science, Engineering and Technology

(An ISO 3297: 2007 Certified Organization)

Vol. 5, Special Issue 9, May 2016

Table 1: Modal analysis results for pumping diaphragm amplifier

Mode	Frequency
1	328.48
2	496.02
3	507.60

The first mode shape was obtained at a frequency of 328.48Hz.

IV. SIMULATION

Simulations are performed in the MATLAB Simulink software to determine the pumping diaphragm actuator displacement and the valve diaphragm actuator displacement. The displacement is obtained by applying voltage to the piezoelectric stack. An input voltage of 150V is applied to the piezoactuator and the displacement is determined. Bouc-Wen model is used to reduce the hysteresis effect. Simulink block diagram is as shown in the figure 6 below.

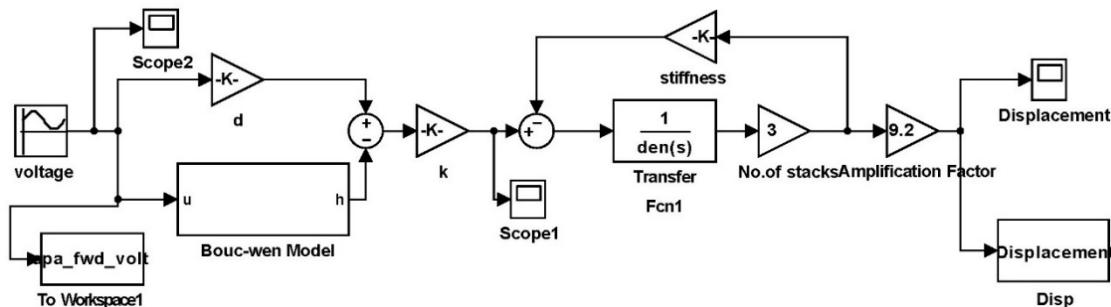

Figure 6: Simulink block diagram

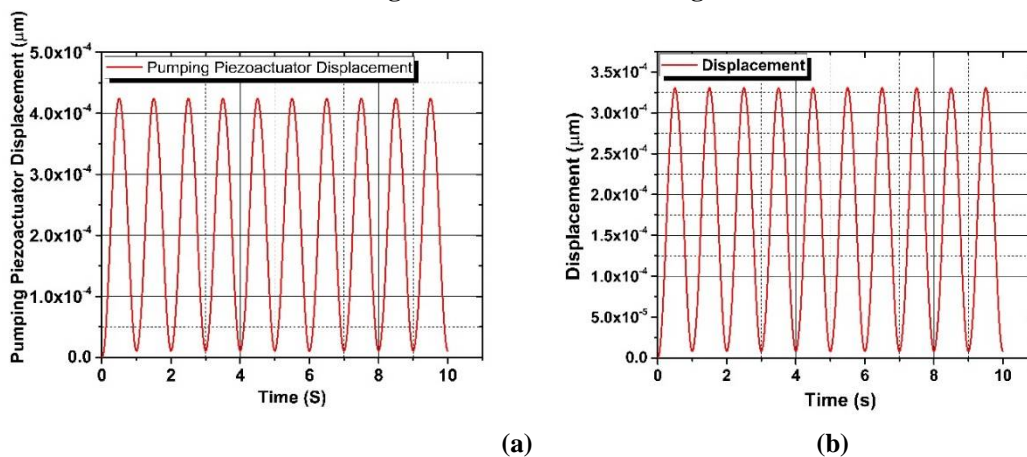

Figure 7: (a) Plot of pumping actuator displacement (b) Plot of valve actuator displacement

From simulation, the displacement obtained for pumping diaphragm actuator is 424μm and that for valve diaphragm actuator is 330μm.

V. EXPERIMENTS FOR STIFFNESS AND RESONANT FREQUENCY

A force sensing resistor(FSR) is used to sense the force that is being applied using a vice and the voltage amplifier circuit is used to convert the applied force into equivalent voltage. The LASER sensor is used to measure the displacement of the flexural amplifier for corresponding force. The displacement is noted at both the ends of the

International Journal of Innovative Research in Science, Engineering and Technology

(An ISO 3297: 2007 Certified Organization)

Vol. 5, Special Issue 9, May 2016

amplifier for every trial and the total Z-Direction deflection is calculated. The voltage amplifier circuit used here is a wheatstone bridge circuit with one of the resistor as FSR. The FSR is basically a variable resistor whose resistance will decrease with increase in the applied force. As the resistance decreases there will be change in the output voltage of the circuit. Using the obtained voltage values the force is calculated using an equation that is obtained from the calibration of FSR.

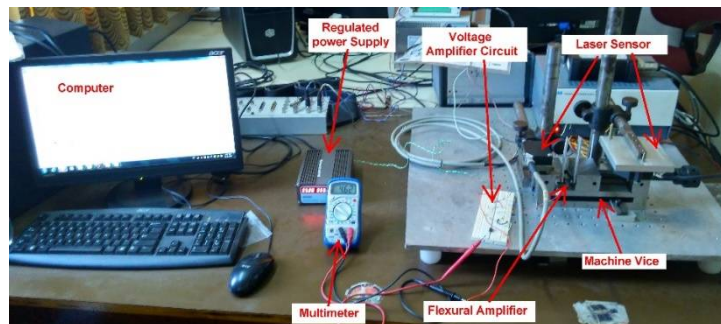

Figure 8: Experimental setup to determine the amplifier stiffness

Calibration is done by applying different load values to the FSR and the corresponding voltage values are noted down. A graph is plotted with voltage versus the load applied, an equation for force is fit that best suites the graph. Using this equation corresponding force values can be calculated for any given voltage value.

Table 2: Experimental values for pumping amplifier

Force (N)	Displacement (μm)	Stiffness ($\text{N}/\mu\text{m}$)
21.77	45	0.4838
25.11	63	0.3986

Table3: Experimental values for valve amplifier 2

Force (N)	Displacement (μm)	Stiffness ($\text{N}/\mu\text{m}$)
29.1160	328.11	0.0887
36.1596	605.36	0.0597

Average stiffness value = $0.4412\text{N}/\mu\text{m}$ Average Stiffness value = $0.0742\text{N}/\mu\text{m}$

The results obtained for Z-Direction stiffness of flexural amplifier in ANSYS analysis and the experimental results are approximately equal.

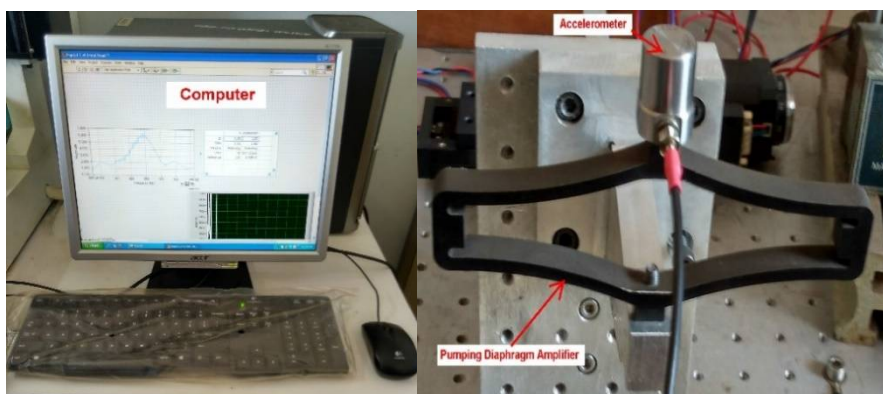

Figure 9: Experimental setup to determine the resonant frequency

International Journal of Innovative Research in Science, Engineering and Technology

(An ISO 3297: 2007 Certified Organization)

Vol. 5, Special Issue 9, May 2016

NI PCI-4472 data acquisition system is used to acquire the vibration signals from the accelerometer (MMF KD37V). Sound and vibration module of the LabVIEW software is used to analyse data obtained from accelerometer. The lower end of the pumping diaphragm amplifier is rigidly fixed to a bolting base and the upper end of the amplifier is fixed with an accelerometer. An impact load is applied to the amplifier by generally tapping on it and the corresponding resonant frequency plot is obtained in the software. The experimental plot obtained from the LabVIEW software is as shown in the figure10 below.

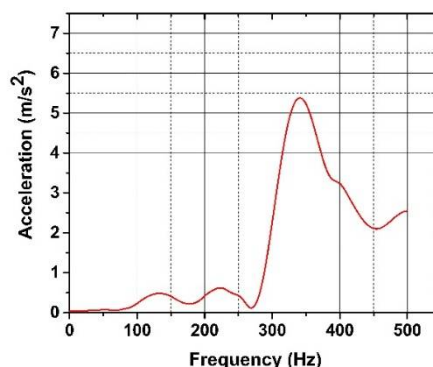

Figure 10: Resonant frequency plot for pumping diaphragm actuator

From the experiment the first frequency is obtained approximately 330Hz. The modal analysis and experimental results are in good agreement with each other.

VI.CONCLUSION

In this paper design of a high pressure piezohydraulic pump incorporated with active valve control is performed. Flexurally amplified piezoelectric actuators are designed for actuation of pumping diaphragm and valve diaphragm. Load-displacement analysis of the amplifiers is carried out using ANSYS analysis software. Material used for the flexural amplifiers is spring steel. From the analysis it is found that flexural amplifier of pumping diaphragm actuator yielded a stiffness value of 0.4310N/ μm in Z-direction and 24.155N/ μm in X-direction with an amplification factor of 9.28. Analysis of flexural amplifier for valve diaphragm actuator yielded a stiffness value of 0.0767N/ μm in Z-direction and 11.0803N/ μm in X-direction with an amplification factor of 14.72. Also modal analysis is performed for the pumping diaphragm actuator for the safe operation of pump. The first modal frequencies obtained is 328.48Hz for pumping diaphragm actuator. Simulation is performed to determine the displacement of actuators. The displacement obtained for pumping diaphragm actuator is 424 μm and for the valve diaphragm actuator is 330 μm . Experiments are carried out to determine the stiffness of both the actuators. Experiments for pumping diaphragm actuator yielded a stiffness value of 0.4412N/ μm and that for the valve diaphragm actuator yielded a stiffness value of 0.0742N/ μm . Also experiments are carried out to determine the natural frequency of pumping diaphragm actuator. The experiments resulted in a value of 330Hz as its first peak. The experimental and analysis results are in close agreement.

REFERENCES

- [1] Dong Gun Lee, Siu Wing or and Gregory p. Carman, "Design of piezoelectric-hydraulic pump with active valves", Journal of intelligent material systems and structures 15 (2004): 107-115.
- [2] M. Shen, L. Dovat and M.A.M. Gijs, "Magnetic active-valve micropump actuated by a rotating magnetic assembly", sensors and actuators B 154 (2009): 52-58.
- [3] Jun Shinohara, Masayuki Suda, Kazuyoshi Furuta and Toshihiko Sakuhara, "High Pressure-Resistance Micropump using Active and Normally-Closed Valves using Micromachine Technology", (2000): 86-91.
- [4] Pramathesh T and Ankur S, "Piezoelectric crystals: Future source of electricity", International journal of scientific engineering and technology 2 (2013): 260-262.