

Power Stability and Oscillation Damping Analysis of a Three Machine Nine Bus System

Suraj Kumar, Priyajit Dash

M.Tech Student, Department of EEE, BRCM College of Engineering, Behal, Bhiwani Haryana, India

Asst. Professor, Department of EEE, BRCM College of Engineering, Behal, Bhiwani Haryana, India

ABSTRACT:Power System is subjected to sudden changes in load levels. Stability is an important concept which determines the stable operation of power system. In general rotor angle stability is taken as index, but the concept of transient stability, which is the function of operating condition and disturbances, deals with the ability of the system to remain intact after being subjected to abnormal deviations. A system is said to be synchronously stable (i.e., retain synchronism) for a given fault if the system variables settle down to some steady-state values with time, after the fault is removed. For the improvement of transient stability, the general methods adopted were fast acting exciters, circuit breakers and reduction in system transfer reactance. With the growth of power system industry new ideas and techniques developing day by day which results entrance and use of FACTS devices in the existing system for effective utilization of existing transmission resources. In this paper we will design various simulink models on MATLAB Simulink for analysis of improvement in the Transient Stability of 9 Bus 3 machine System with SSSC, TSCS, and SVC for better results.

KEYWORDS: SVC, FACTS, TSCS, SSSC, VAR, Controller, Damping Oscillation

I. INTRODUCTION

As Electricity is backbone for almost all economic activities in present times and it is a proven fact that access of this precious perishable commodity to people bears direct impact on pace of development of the country. With rapid industrialization and increasing population the demand for electricity is increasing day by day. Existing power system is expanding due to increased demand and becoming more complex with different types of loads and generation from varied and distributed resources and with new technology and restructuring of electrical power system adds to the complexity of the modern power system.

Expansion of power system along with restructuring and deregulation the complexity of system is increasing continuously. Demand for additional load and requirement of good power quality by consumers makes the use of compensation devices a necessity. These compensation devices add to utilities complexity and expenses, so it becomes important to use them at a location which offers a better compensation and proper utilization of these devices.

Fundamental Requirement of a Designed Power System

1. It must supply energy at minimum cost and minimum ecological impact.
2. It must be able to meet continuously changing demand of both active and reactive power.
3. Quality of power should meet should meet certain minimum standards in
 - a. Constant frequency.
 - b. Constant voltage.

In modern interconnected power system the effect of instability or poor power quality is on both power system and load connected to it. Modern information age increasing use of computers and sophisticated electronic devices requires with a very good power that remains within specified limits of voltage for their proper functioning. This needs great stress on quality of electrical power being supplied to the load. Poor quality power sometimes causes serious economic consequences and cost business millions of rupees each year in revenues loss, process improvements, and scrapped product in industrial assembly lines which are increasingly automated and work on

International Journal of Innovative Research in Science, Engineering and Technology

(An ISO 3297: 2007 Certified Organization)

Vol. 5, Issue 7, July 2016

semiconductor equipments control which are sensitive to the quality of power being supplied.

II. LITERATURE REVIEW

The SSSC, which was proposed by B.Vijyalaxmi in 2013[8], [16],[17],[19] is one of the most complex FACTS devices in a power system today. The SSSC is one of the series FACTS device based on a solid state voltage source inverter which generates a controllable ac voltage in Quadrature with the line current. Thus SSSC emulates as an inductive or capacitive reactance and hence controls the power flow in the transmission line. If the line voltage is in phase with the line current the series controller absorbs or produces reactive power. If it is not then the controllers absorbs or produces real and reactive power. SSSC is also used to damp the power system oscillations by using power oscillation damping controller.

The SVC is a shunt device of the FACTS group using power electronics to control power flow and improve transient stability on power grids [5], [18],[6],[15]. The SVC regulates voltage at its terminals by controlling the amount of reactive power injected into or absorbed from the power system. When system voltage is low, the SVC generates reactive power (SVC capacitive). When system voltage is high, it absorbs reactive power (SVC inductive). Several references in technical literature can be found on development of SVC. Dynamic models of SVC for transient stability and longer term dynamics is modeled on the basis of transfer function model by using conventional PI control used. In, a new SVC control for damping of power oscillations has been developed by using the phase angle signal estimated from the measurement of voltage and power at the SVC location. In, developed control laws for damping of power oscillations using SVC based on local input signal VSVC (SVC voltage). This control structure is decentralized and does not need any coordination with the other Power oscillation damping devices.

The 3-machine 9-bus system has been proposed in [9] [13].It is widely accepted that transient stability is an important aspect in designing and upgrading electrical power system. In this for various faults on test system fast clearing and load shed are analyzed to bring back the system to the stability.

The proposed definition of power system stability has been proposed in [6]. In this it is stated that how many types of stability are there in power system such as voltage, frequency and transient stability. And after that these stability can be for short duration or longer duration. In this thesis FACTS devices are used to damp this stability.

The TCSC which is a series device has been proposed in[11]. It can be used as both inductive and capacitive. It can also be used to damp the power system oscillations in the system. It is also used to increase the power transfer capability.

III. POWER SYSTEM STABILITY

Power system stability is the ability of an electrical power system for a given initial operating conditions to regain a state of operating equilibrium after being subjected to a physical disturbance with most system variable bounded so that practically the entire system remain intact.

A. Classification of Power System Stability

The classification of power system stability proposed here is based on the following considerations

1. The physical nature of the resulting mode of instability as indicated by the main system variable in which instability can be observed.
2. The size of the disturbance considered which influences the method of calculation and prediction of stability.
3. The devices, processes and the time span that must be taken into consideration in order to assess stability.

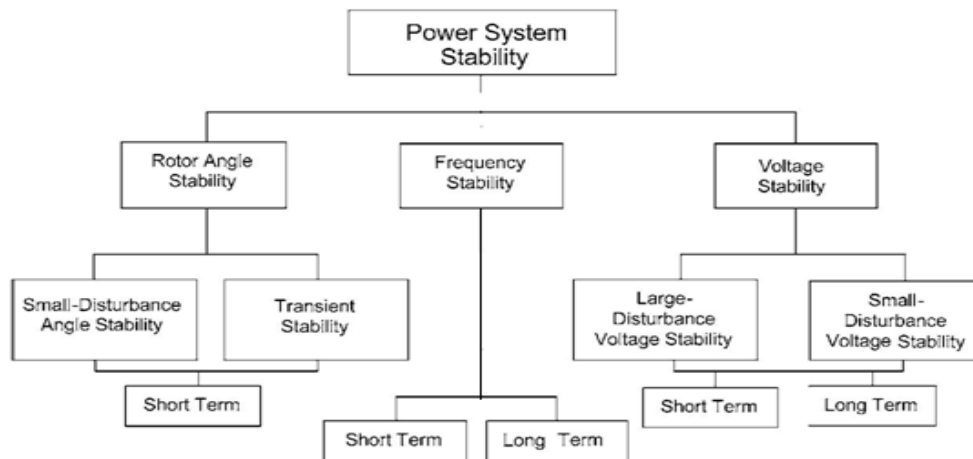

Fig 1 Classification of power system stability

Rotor Angle Stability:

Rotor angle stability refers to the ability of synchronous machines of an interconnected power system to remain in synchronism after being subjected to a disturbance. It depends on the ability to maintain/restore equilibrium between electromagnetic torque and mechanical torque of each synchronous machine in the system. Instability that may result occurs in the form of increasing angular swings of some generators leading to their loss of synchronism with other generators.

The rotor angle stability problem involves the study of the electromechanical oscillations inherent in power systems. A fundamental factor in this problem is the manner in which the power outputs of synchronous machines vary as their rotor angles change. Under steady state conditions, there is equilibrium between the input mechanical torque and the output electromagnetic torque of each generator, and the speed remains constant. If the system is perturbed, this equilibrium is upset, resulting in acceleration or deceleration of the rotors of the machines according to the laws of motion of a rotating body. If one generator temporarily runs faster than another, the angular position of its rotor relative to that of the slower machine will advance. The resulting angular difference transfers part of the load from the slow machine to the fast machine, depending on the power-angle relationship. This tends to reduce the speed difference and hence the angular separation. The power-angle relationship is highly nonlinear. Beyond a certain limit, an increase in angular separation is accompanied by a decrease in power transfer such that the angular separation is increased further. Instability results if the system cannot absorb the kinetic energy corresponding to these rotor speed differences. For any given situation, the stability of the system depends on whether or not the deviations in angular positions of the rotors result in sufficient restoring torques. Loss of synchronism can occur between one machine and the rest of the system, or between groups of machines, with synchronism maintained within each group after separating from each other.

The change in electromagnetic torque of a synchronous machine following a perturbation can be resolved into two components:

1. Synchronizing torque component in phase with rotor angle deviation.
2. Damping torque component in phase with speed deviation.

System stability depends on the existence of both components of torque for each of the synchronous machines. Lack of sufficient synchronizing torque results in a periodic or non oscillatory instability, whereas lack of damping torque results in oscillatory instability.

Voltage Stability:

Voltage stability refers to the ability of a power system to maintain steady voltage at all the buses in the system after being subjected to a disturbance from a given initial operating condition. It depends upon the ability to maintain equilibrium between load demand and load supply from the power system. Instability that may result occurs in the form of a progressive rise or fall of voltage of some buses. A possible outcome of voltage instability is loss of load in an area or

International Journal of Innovative Research in Science, Engineering and Technology

(An ISO 3297: 2007 Certified Organization)

Vol. 5, Issue 7, July 2016

tripping of transmission lines and other elements by protective system leading to cascading outages. Loss of synchronism of some generators may result from these outages or from operating conditions that violate field current limit.

Progressive drop in bus voltage may also be associated with rotor angle stability. For example loss of synchronism of machine or rotor angle between two groups of machine approach 180 degree cause rapid drop in voltage at intermediate point in network close to the electrical centre. Normally protective system operate to separate the group of two machines and the voltage recover to level depending on post separation condition. If however the system is not so separated the voltage near the electrical centre rapidly oscillates between high and low values as a result of repeated pole slips between the two groups of machines.

Frequency Stability:-

It refers to the ability of a power system to maintain steady frequency following a severe system upset resulting in a significant imbalance between generation and load. It depends on the ability to maintain/restore equilibrium between system generation and load, with minimum unintentional loss of load. Instability that may result occurs in the form of sustained frequency swings leading to tripping of generating units and/or loads.

Severe system upsets generally result in large excursions of frequency, power flows, voltage, and other system variables, thereby invoking the actions of processes, controls, and protections that are not modeled in conventional transient stability or voltage stability studies. In large interconnected power systems, this type of situation is most commonly associated with conditions following splitting of systems into islands. Generally, frequency stability problems are associated with inadequacies in equipment responses, poor coordination of control and protection equipment, or insufficient generation reserve

During frequency excursions, the characteristic times of the processes and devices that are activated will range from fraction of seconds, corresponding to the response of devices such as under frequency load shedding and generator controls and protections, to several minutes, corresponding to the response of devices such as prime mover energy supply systems and load voltage regulators. Therefore frequency stability may be a short-term phenomenon or a long-term phenomenon. An example of short-term frequency instability is the formation of an under generated island with insufficient under frequency load shedding such that frequency decays rapidly causing blackout of the island within a few seconds. On the other hand, more complex situations in which frequency instability is caused by steam turbine over speed controls or boiler/reactor protection and controls are longer-term phenomena with the time frame of interest ranging from tens of seconds to several minutes.

III. SIMULINK MODEL AND RESULT ANALYSIS

The simulation studies in this paper are based on 230 kV 3 machine 9 bus power system consists of three generators connected in transmission line network as shown in fig. 2 each generator is of 700 MVA capacity. Three machines nine buses system having capacity of each generator equals to 700 MVA through a transmission line network. The SVC,SSSC and TCSC is installed at middle transmission line respectively in order to control the power flow through that line as well as to regulate voltage level at buses.

International Journal of Innovative Research in Science, Engineering and Technology

(An ISO 3297: 2007 Certified Organization)

Vol. 5, Issue 7, July 2016

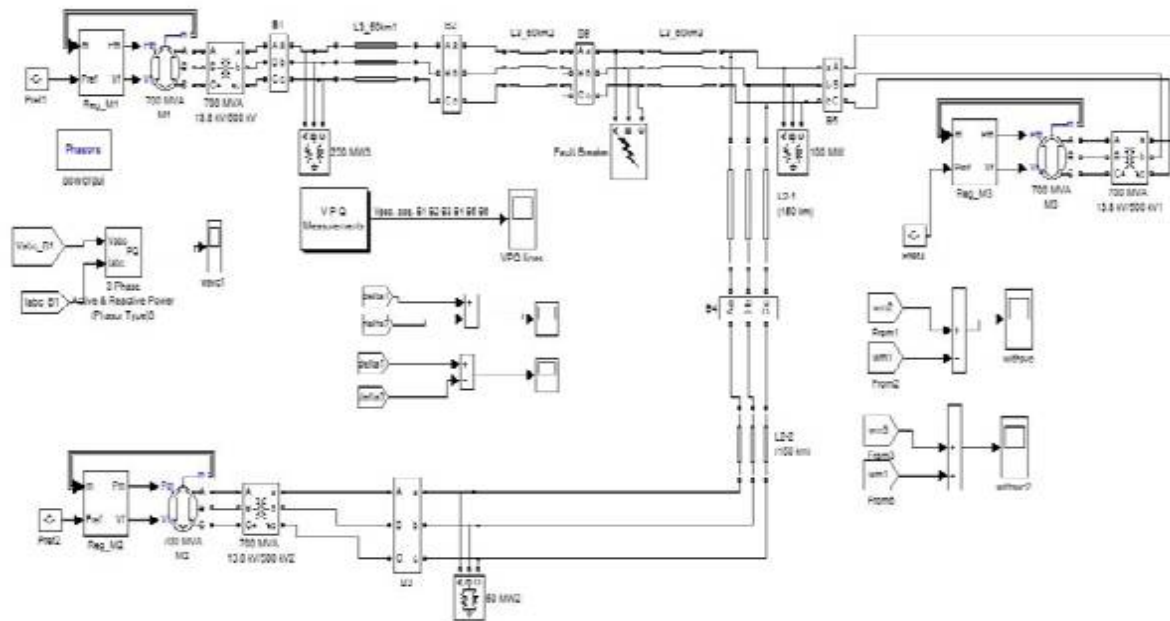

Fig 2. Simulink model of 3 machine 9 bus system

Simulink model with SSSC

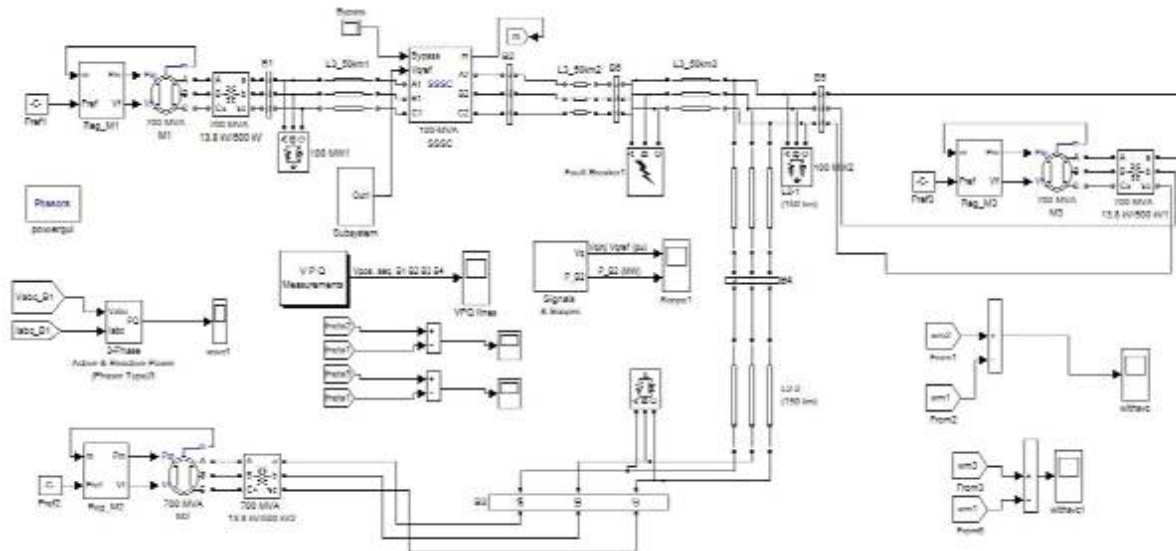

Fig 3 Simulink model with SSSC

Circuit Description

The Static Synchronous Series Compensator (SSSC), one of the key FACTS devices, consists of a voltage-sourced converter and a transformer connected in series with a transmission line. The SSSC injects a voltage of variable magnitude in quadrature with line current, thereby emulating an inductive or capacitive reactance. This emulated variable reactance in series with the line can then influence the transmitted electric power. In our thesis, the SSSC is used to damp power oscillation on power grid following a 3-phase fault.

Simulink model with TCSC

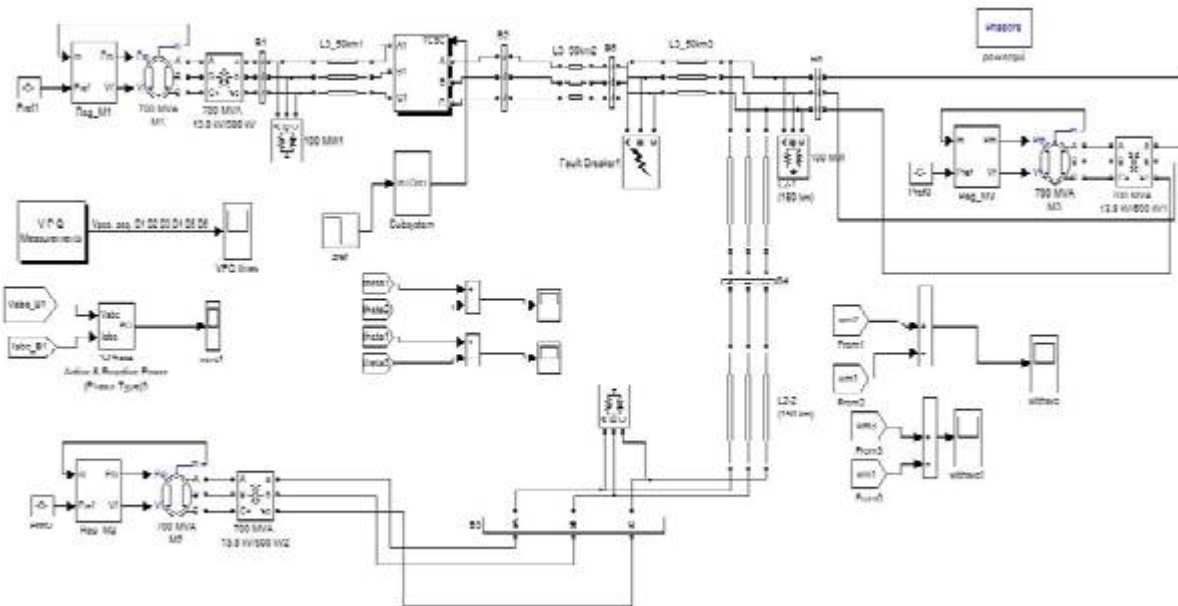

Fig 4 Simulink model with TCSC

Circuit Description

Generally TCSC is used to improve power transfer capability. But we can use it also to improve transient stability in power system. It can be used in two mode inductive as well as capacitive. We can switch from one mode to other whenever it is required. It contain a capacitor controlled by the thyristor.

Simulink model with SVC

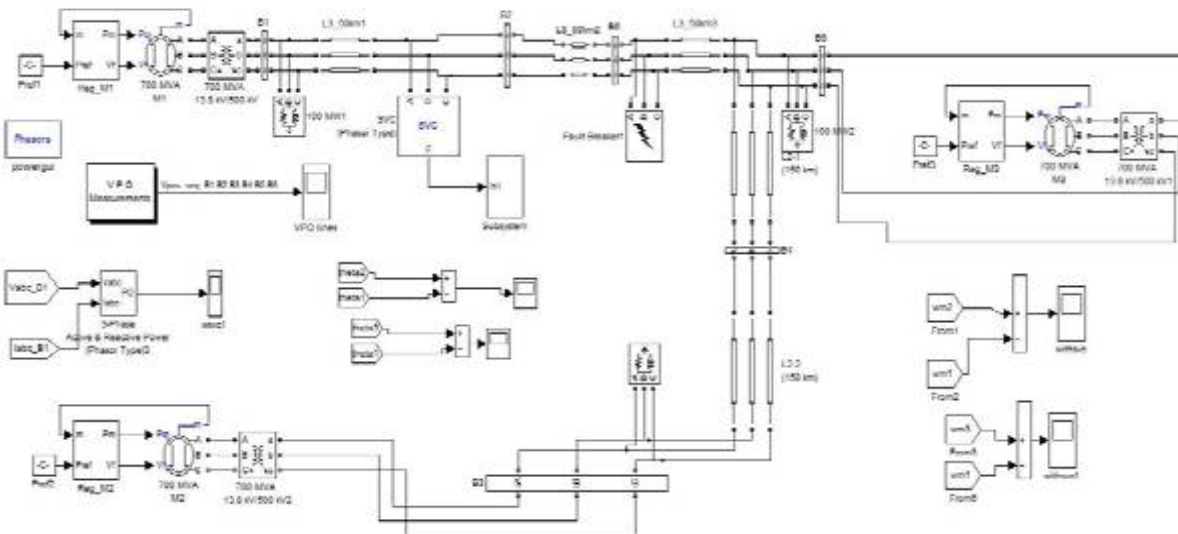

Fig 5 Simulink model with SVC

International Journal of Innovative Research in Science, Engineering and Technology

(An ISO 3297: 2007 Certified Organization)

Vol. 5, Issue 7, July 2016

Circuit Description

You will now apply a 3-phase fault and observe the impact of the SVC for stabilizing the network during a severe contingency. Verify that the SVC is in fixed susceptance mode with $B_{ref} = 0$. Start the simulation. Now open the SVC block menu and change the SVC mode of operation to 'Voltage regulation'. The SVC will now try to support the voltage by injecting reactive power on the line when the voltage is lower than the reference voltage (1.009 pu). The chosen SVC reference voltage corresponds to the bus voltage with the SVC out of service. In steady state the SVC will therefore be 'floating' and waiting for voltage compensation when voltage departs from its reference set point.

Comparison of result between the devices

A. Comparison between SVC and TCSC 1.

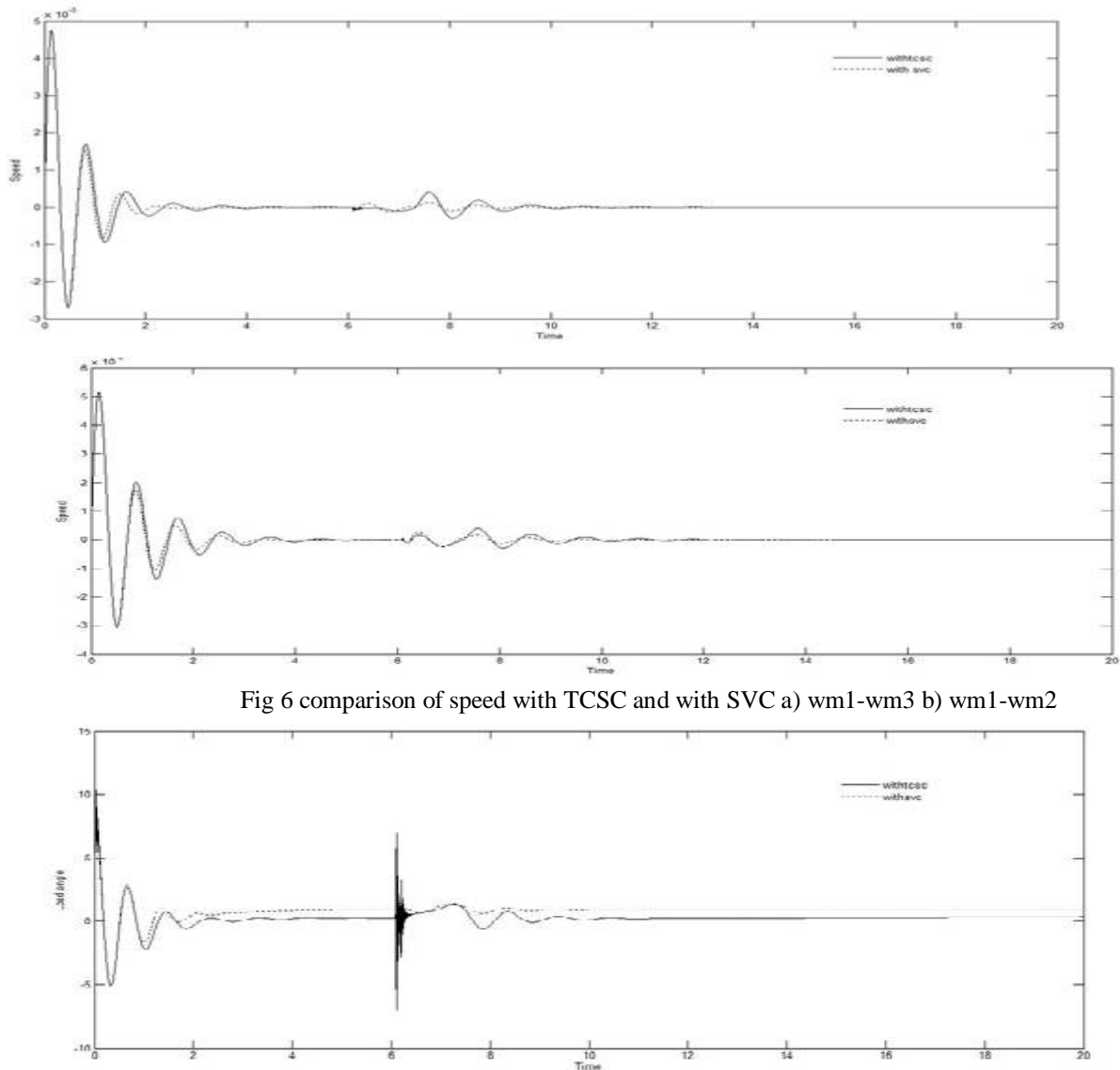

Fig 6 comparison of speed with TCSC and with SVC a) wm1-wm3 b) wm1-wm2

International Journal of Innovative Research in Science, Engineering and Technology

(An ISO 3297: 2007 Certified Organization)

Vol. 5, Issue 7, July 2016

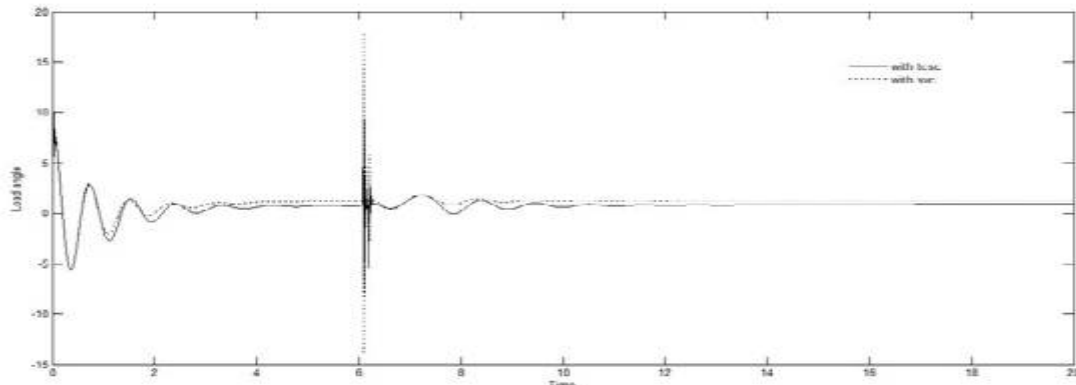

Fig 7 Comparison of load angle with TCSC and with SVC a) Delta1 b) Delta 3

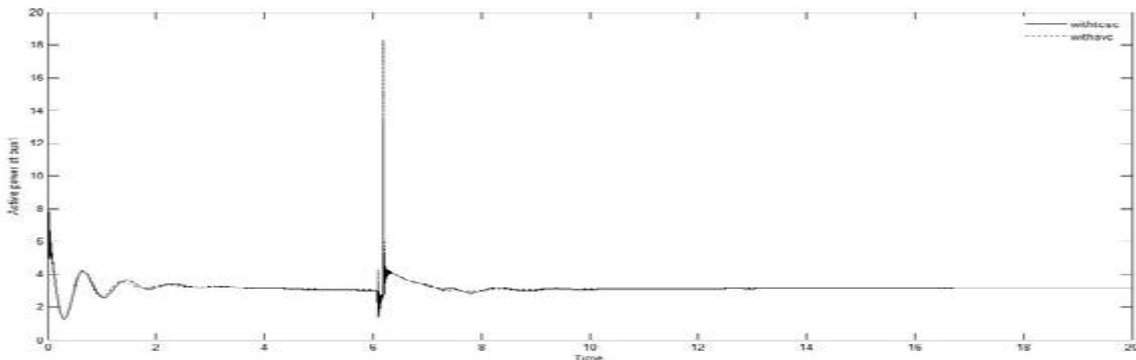

Fig 8 comparison of active power at Bus 1 with TCSC and with SVC

Simulation results for speed, load angle and active power for synchronous machines of 3 machine 9 bus system is shown in above fig. Three phase symmetric fault of 100 milliseconds is applied at time 6.1 second. After the occurrence of fault the power curve show oscillations which are settled to steady state. To damp the oscillations two controllers are applied and then their performance is compared. Here we have applied TCSC and SVC and we have observed that SVC gives better result means it is damping oscillation in less time as compared to TCSC.

B. Comparison between SVC and SSSC 1.

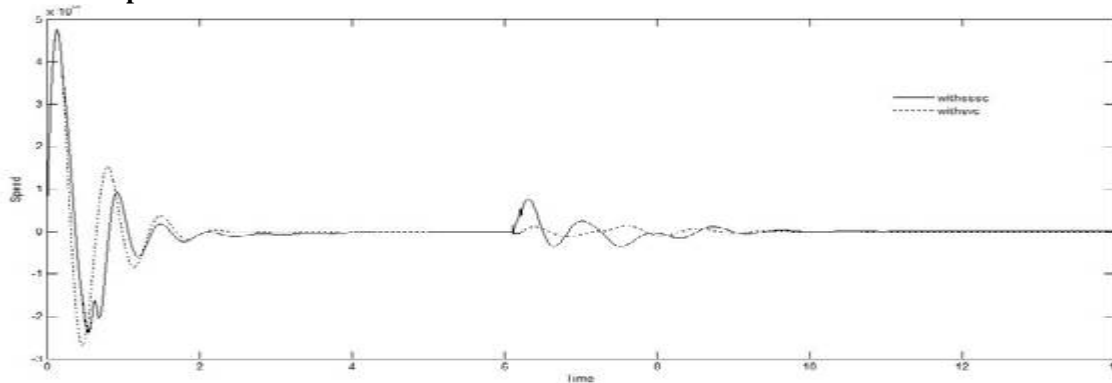
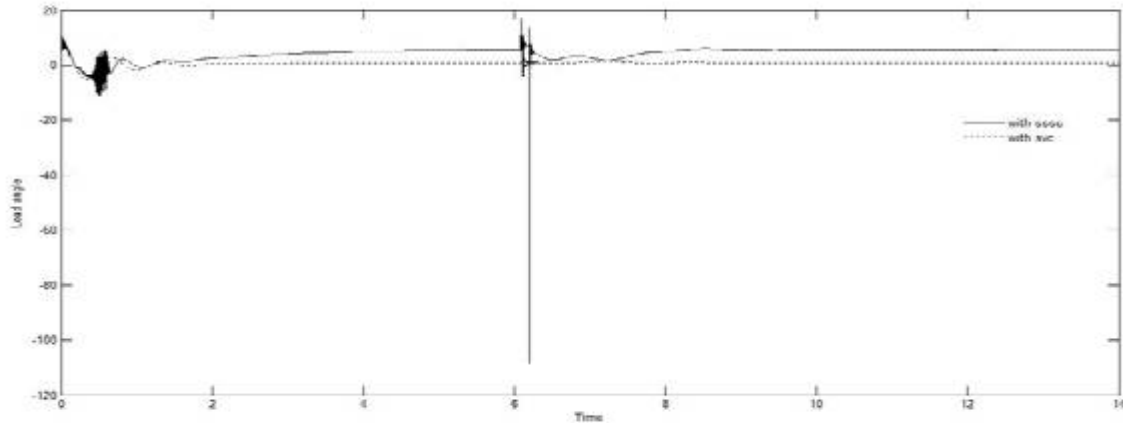

Fig 9 Comparison of speed(wm1-wm3) with SSSC and with SVC

International Journal of Innovative Research in Science, Engineering and Technology

(An ISO 3297: 2007 Certified Organization)

Vol. 5, Issue 7, July 2016



Simulation results for speed, load angle for synchronous machines of 3 machine 9 bus system is shown in above fig. Three phase symmetric fault of 100 milliseconds is applied at time 6.1 second. After the occurrence of fault the power curve show oscillations which are settled to steady state. To damp the oscillations two controllers are applied and then their performance is compared. Here we have applied SSSC and SVC and we have observed that SVC gives better result means it is damping oscillation in less time as compared to SSSC.

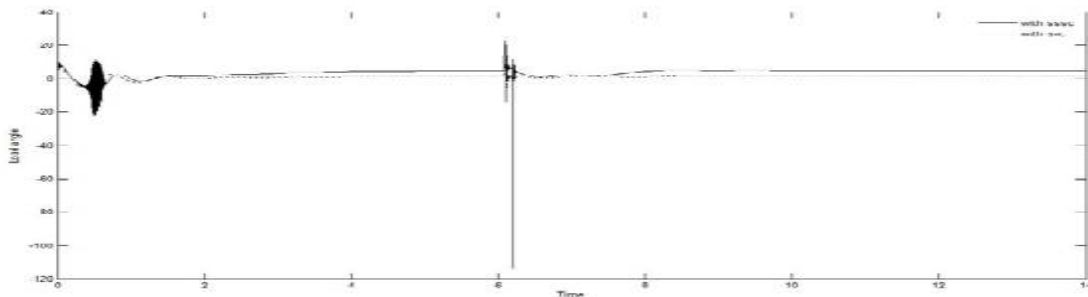
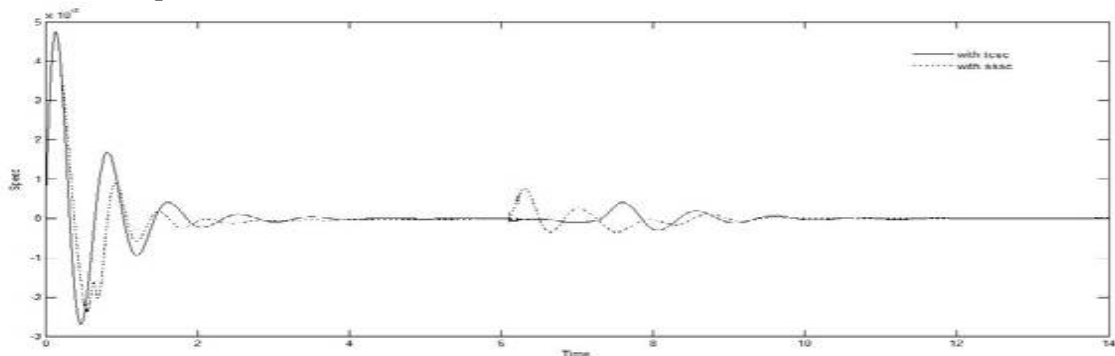

Fig 10 Comparison of Load angle with SSSC and with SVC a) Delta1-Delta3 b) Delta1-Delta2

C. Comparison between SSSC and TCSC 1.



International Journal of Innovative Research in Science, Engineering and Technology

(An ISO 3297: 2007 Certified Organization)

Vol. 5, Issue 7, July 2016

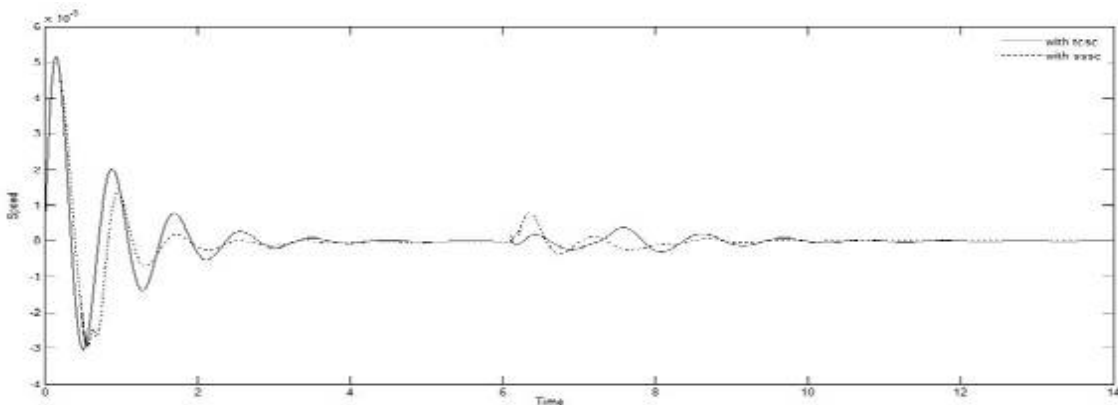

Fig 11 Comparison of Speed with TCSC and with SSSC a) wm1-wm3 b) wm1-wm2

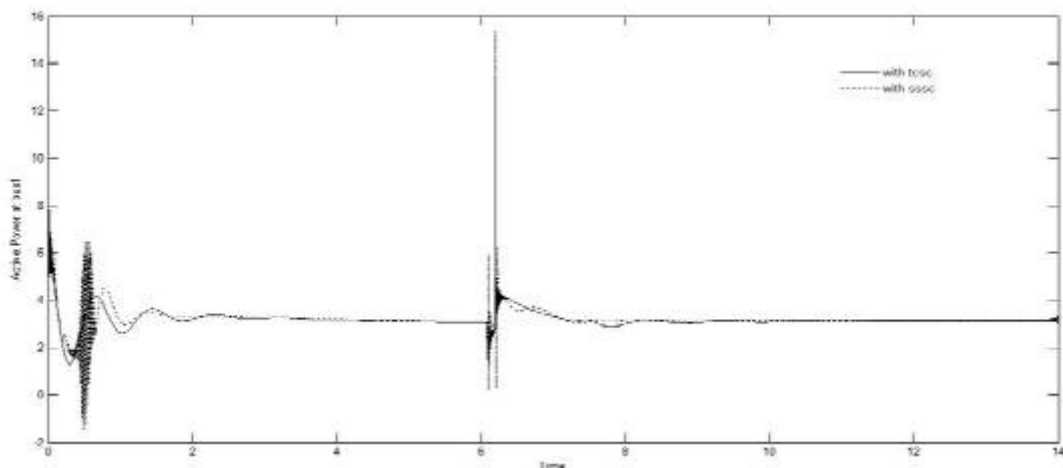

Fig 12 Comparison of active power at Bus 1 with SSSC and with TCSC

Simulation results for speed, load angle for synchronous machines of 3 machine 9 bus system is shown in above fig. Three phase symmetric fault of 100 milliseconds is applied at time 6.1 second. After the occurrence of fault the power curve show oscillations which are settled to steady state. To damp the oscillations two controllers are applied and then their performance is compared. Here we have applied SSSC and TCSC and we have observed that SSSC gives better result means it is damping oscillation in less time as compared to TCSC.

IV. CONCLUSION

In this thesis, the power system stability improvement of a 3 machine 9 bus power system by various FACTS devices such as SVC, SSSC AND TCSC is analysed. The effect of SVC, SSSC and TCSC on power system stability of 3 machine 9 bus power system is studied. The dynamics of the system is studied at the event of a major disturbance and three phase symmetric fault of 100ms and the results are discussed. Then the performance of the devices is compared for power system stability improvement . It is clear from the simulation results that there is a considerable improvement in the system performance with the presence of these devices for which the settling time is reduced. It is also observed SVC is better than SSSC and TCSC and SSSC is better than TCSC. The oscillations is also reduced and hence the power system stability is improved

International Journal of Innovative Research in Science, Engineering and Technology

(An ISO 3297: 2007 Certified Organization)

Vol. 5, Issue 7, July 2016

REFERENCES

- [1] H.F. Wang, Proposed Design of damping controller to improve power system oscillations stability, IEEE transactions on power delivery isbn no 0-7803-5546-6/99 year 1999.
- [2] Pranesh rao ,M.L. Crow, Defined STATCOM control for power system voltage control applications IEEE transactions on power delivery Vol 15 no.4 oct.2000.
- [3] N.G. Hingorani and L.Gyugi, Understanding FACTS – Concepts and Technology of flexible ac transmission systeml, standard publishers Distributors ,IEEE papers, new York 2001.
- [4] K.R. Padiyar ,2002,IPower system dynamic stability and controll second edition, BS publication hydrabad.
- [5] Sidhartha Panda,R.N. Patel,IProposed Improving power system transient stability using on/off shunt FACTS devicsl ,Journal of electrical engineering vol.57 no 6 year 2006.
- [6] Mathias wien ,IProposed performance analysis of SVCl, IEEE transactions on power delivery vol 17 no.9 year 2007.
- [7] Prabha Kundur,John Preseba ,IDefinition and classification of power system stabilityl,IEEE transacions on power system year 2008.
- [8] M.reyes,S.vazquez,M.B. Ferrera ,IProposed voltage measurement control of a SSSCl,IEEE transaction on power delivery ISBN-978-1-4244-6392-3/10 year 2010.
- [9] A.S. Kannan, R.Kayalvizhi,IProposed Noval design of a fuzzy coordinated SSSC controller for integrated power systeml,IJPTE journal ISSN 2077-3528 vol.3 year 2011.
- [10] M.Faridi, H.Maeiat ,Iproposed Power system stability enhancement using SSSCl,ISBN-978-1-61284-840-2/11 year 2011.
- [11] K.sirinivas ,IProposed Application of FUZZY coordinated TCSC in multi machine system for transient stability improvement.IJFCP vol.48 no.19 year 2012.
- [12] B.V. Shankar Ram , K.R.M. Rao,IPropsed Automatic control of Thyristor Controlled Series Capacitorl,IJERA journal ISSN: 2248-9622 vol.2 issue 3 year 2012.
- [13] Mukesh Kumar, Swaroop kumar ,ITransient stability analysis of IEEE 9-bus electric power systeml,IJSET journal ISSN:2277-1581 IJSET journal year 2012.
- [14] P.Suman Kumar,N. Vijyasimha,ISatic synchronous series compensation foe EHV transmission linesl,ISSN:2320-3765 year 2013.
- [15] Nitin Sexana , Arvind Pahade ,ITransient stability improvent by using shunt FACTS devicsl,IJECE journal ISSN:2277-2626 year 2013.
- [16] D.V.N. Anantha,B. Vijyalaxmi,IProposed Performance Analysis of power oscillations damping SSSC FACTS devicsl,IJAREIEE journal ISSN:2320-3765 year 2013.
- [17] Sahil Chauhan,Suman Bhullar,IProposed Power Flow improvement in transmission network using SSSCl,IJERT journal year 2013.
- [18] Alok kumar,Surya Bhushan ,IProposed Enhancement of Transient stability in transmission line using SVC FACTS controllerl,IJECE journal ISSN:2277-3878 year 2013.
- [19] Prashant Dhoble,Arti Bhandakkar ,IProposed Active reactive power flow control using Static Synchronous Series Compensatorl, IOSR-JEEE journal ISSN:2320-3331 year 2013.
- [20] S.Prabhakaran,M.laxman,IProposed Enhancement of transient stability in a 9 bus system using UPFC,I JSR journal ISSN:2319-7064 year 2014.
- [21] Vinesh Aggarwal, Dipesh M.Patel,IProposed Improving Power system transient stability by using FACTS devicsl,IJERT journal ISSN:2278-0181 year 2014.