

Fire Fighting Robot Controlled Using Android Application

Prof.Dr. S.N. Kini¹, Rutuja Wadekar², Shweta Khatade³, Sayali Dugane⁴, Rutuja Jadkar⁵.

Professor, Dept. of Computer Engineering, JSCOE, Hadapsar, Pune, India¹.

UG Student, Dept of Computer Engineering, JSCOE, Hadapsar, Pune, India^{2,3,4,5}.

ABSTRACT: Detection of fire at an early stage can avoid loss. Normally fire causes huge damage because of absence of human beings to detect fire. If fire is detected and extinguished at an early stage, one can avoid loss of life and property. Robotics has gained popularity due to the advancement of many technologies. Properly equipped Robot will detect fire. Once fire is detected equipped robot can be instructed to extinguish fire. The robot is mounted with sensors and fire extinguisher. The light and smoke sensor will detect fire and extinguisher will extinguish fire. In this paper we will discuss the development of android application that will control the robot. In this way we develop full fledged robot to perform fire fighting.

KEYWORDS: Fire source detection, Navigation, Sensors, Fire extinguishing, Android.

I. INTRODUCTION

Previously Fire Fighting Robots were controlled by electronic devices mounted on them. This resulted in limited control of fire fighting robots. However, with advancement in technology, the same robot can be controlled remotely by using a smart phone. Hence our project aims to control the robot using Android Application. The main objective of this paper is to design an android application to control the operation of robot. Robot is able to patrol prescribed area and extinguish fire. With the help of such robots, work of firemen will be easier and effective regardless of security. It will perform task faster. Android devices are powerful mobile equipment which have become popular in the world. Many smart phones are using the android operating system because of its portability and many other features. We will develop android application to control fire fighting robot which is capable of navigation. The main aim of the project is to design android application to control fire fighter robot to perform fire fighting operation. The vehicle is loaded with the fire extinguisher, fire detection sensors i.e. smoke sensor and light sensor.

II. LITERATURE SURVEY

Author Kristi Kosasih et al. Has developed the intelligent fire fighting tank robot. Acrylic, plastic, aluminium and iron are used to make the robot. The tank robot is consisting of components like two servo motors, thermal array sensor, two DC motors, flame detector, ultrasonic sensor, IR and photo transistors, sound activation circuit and micro switch sensor. The goal of paper is search the prescribed area find the fire and extinguish it. The robot is activated by using DTMF transmitter and receiver.

Author SahilS.Shah et al. Have developed the fire fighting robot. The fire fighting robot is integrated with embedded system. Prototype system is designed to detect and extinguish fire. It aims to reduce air pollution caused due to fire. The robot is designed to detect fire in small floor plan. The task of extinguishing fire is divided into smaller tasks. Each task is carried out in most appropriate way. The robot navigates in every room step by step, finds the fire in a room, approaches fire from fixed distance and then extinguishes fire.

International Journal of Innovative Research in Science, Engineering and Technology

(An ISO 3297: 2007 Certified Organization)

Vol. 5, Issue 5, May 2016

III. PROPOSED SYSTEM

Our project is designed to develop android application for remote operation of fire fighter robot. The fire extinguishing system is activated once the sensors detect the fire. Two sensors are used to detect the fire i.e. smoke sensor(light intensity) and another is temperature sensors. When these two sensors are simultaneously activated, the fire is detected. The fire extinguisher is mounted on the robotic vehicle which is then controlled over the wireless communication. At the transmitting end android application device is used. Commands like moving forward, left and right are sent to robot by using android device. At the receiving end, three motors are interface to the microcontroller. Out of these, two motors are used for the movement of robot and one is used to position the arm of the robot. Remote operation is achieved by any smart phone with android operating system. The android application device acts as a remote control. Receiver has a wireless device fed to the microcontroller. Actuator is located on the top of the extinguisher. Actuators are used to activate the sensors. All of the process occurs autonomously without any human intervention.

IV. SYSTEM ARCHITECTURE

System consists of :

1. Android Application
2. Robotic vehicle

Android application consists of a WiFi module that is used to establish connection between the robot and android application. Commands to move forward, left, right and to extinguish fire are sent to the robot through the android application. Android consists of connection, port and commands. Connection is to establish communication between android and the robot. Port is used to establish communication between the android application and the robot. Commands are to give instructions to the robot for navigation and fire extinguishment.

Robotic vehicle consists of MAX232 IC and WiFi module, PIC 16F877A microcontroller, LCD, Relay latch, Motors, MAX232 is an integrated circuit which is used for communication in which conversion of voltage level is required to make devices compatible with serial port and vice versa. MAX232 acts as a mediator between the android application and the PIC microcontroller. It listens the requests sent from the android application and forwards them to the PIC microcontroller. PIC microcontroller processes the requests and sends response to the MAX232. MAX232 forwards the response to the android application. PIC 16F877 is a high performance RISC microcontroller. It provides programmable code protection and power saving sleep mode. It is self programmable under software control having 40 pin package. Of these pin 26 is connected to WiFi module. Pin 38(RB5 port B pin 5) is connected to fire extinguishment system. Pin 39 (RB6 port B pin 6) is connected to motor 2. Pin 40 (RB7 port B pin 7) are connected to the motor 1. Motor1 and motor2 are used for the movement of robot like forward, left, right. Motor 3 is used to position the arm of the robot. The commands of communication between MAX232 and PIC microcontroller are displayed on the LCD. Three motors are connected to the relay latch. Motors perform the navigation and fire fighting operation.

International Journal of Innovative Research in Science, Engineering and Technology

(An ISO 3297: 2007 Certified Organization)

Vol. 5, Issue 5, May 2016

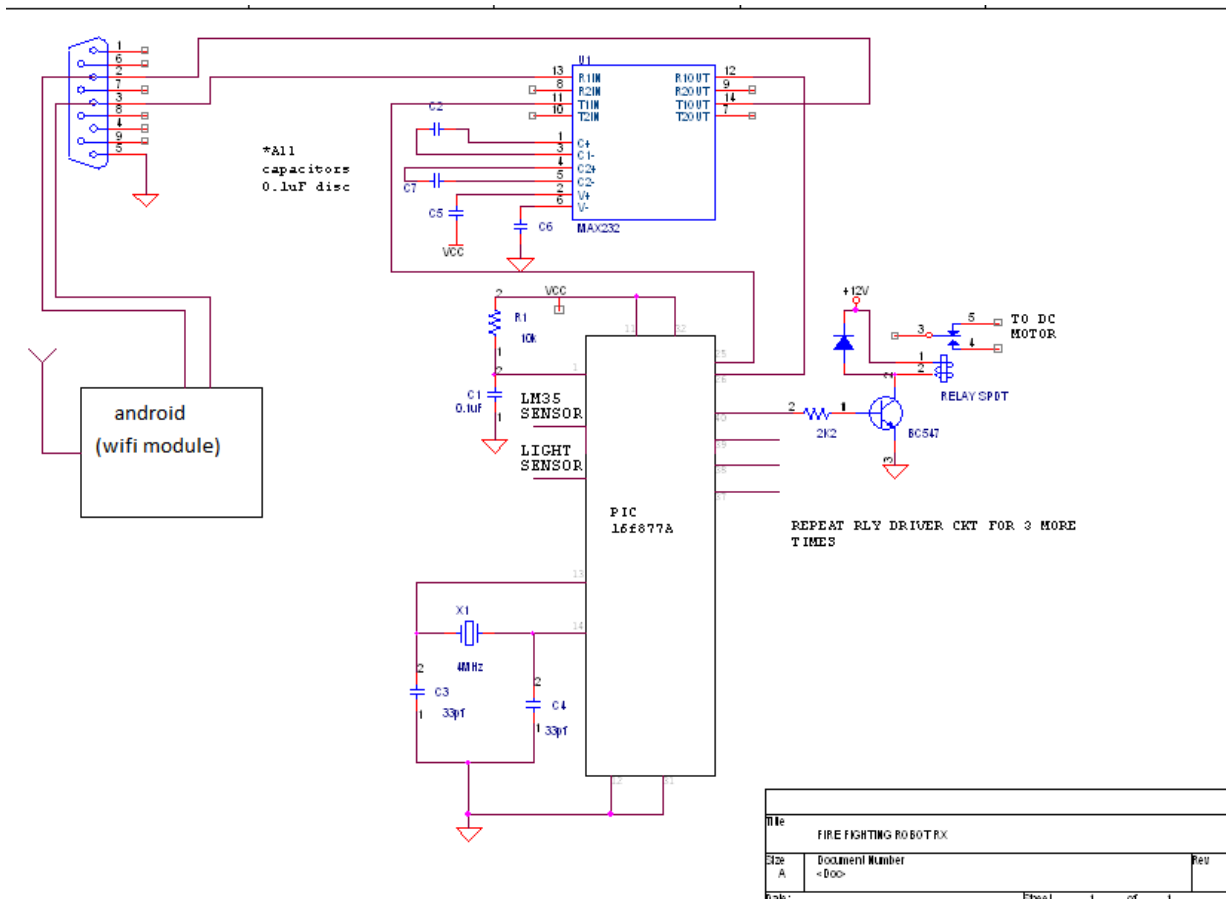

V. ALGORITHM AND WORKING

The working of robot is as follows:

First step is to initialize the port pins of PIC microcontroller. After that UART (Universal Asynchronous Receiver Transmitter) is configured. UART is an individual integrated circuit used for serial communications over a computer or peripheral device serial port. The transmit pin of UART is connected to the receiver of ESP 8266(Wifi) and the transmit pin of ESP is connected to receiver of UART. The baud rate of UART is 9600. Interrupts are enabled to receive commands. The microcontroller will send AT(Attention) command to the Wifi module and wait for response. When it will receive OK response from the Wifi module, it will send AT+RST (Attention+Reset) to the Wifi module. When it will receive OK response from Wifi module, it will send AT+CWMODE=3. When CWMODE is set to 1, the microcontroller will act as a slave. When set to 2, microcontroller act as a master. We have set it to 3 so that it will act as master or slave. When microcontroller will receive OK from Wifi, it will send AT+CIPMUX=1. CIPMUX is used to enable multiple users. After receiving response from Wifi, it will send AT+CIPSERVER=1, 1336. Here, CIPSERVER indicates the microcontroller acts as server or master and the android application is client or slave. 1 is the link number over which communication occurs. Link number can be set from 1 to 4. 1336 is the port number. TCP/IP protocol is used for communication which requires IP and port number. Now it will wait for the control character. If the control character is received, it will be decoded to perform the related task. If the control character received is A, the robot will move forward. If the control character received is B, the robot will move left. If the control character received is c, the

International Journal of Innovative Research in Science, Engineering and Technology

(An ISO 3297: 2007 Certified Organization)

Vol. 5, Issue 5, May 2016

robot will move left. If the control character received is D, the robot will stop the operation. If the control character received is E, then robot will perform fire extinguishment operation.

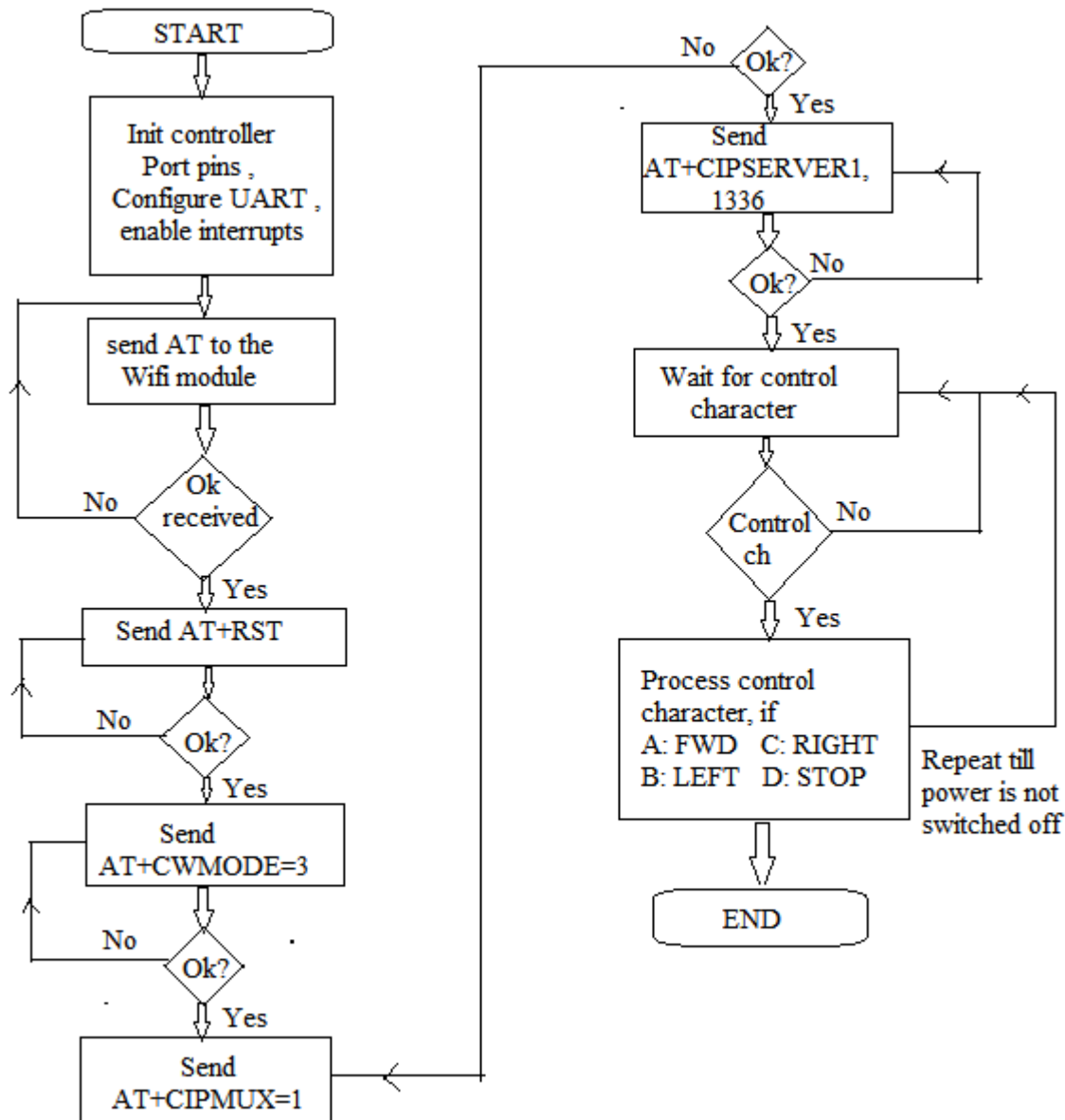

VI. FEATURES

- 1.Intelligent fire detection and suppressions.
- 2.Locate the position of fire origin.
3. Protection of property from loss.
- 4.Minimization of ecological consequences.

International Journal of Innovative Research in Science, Engineering and Technology

(An ISO 3297: 2007 Certified Organization)

Vol. 5, Issue 5, May 2016

- 5. Reliable.
- 6. Path tracking.

VII. FUTURE WORK

The project can be implemented with advancements like:

A robot mounted with camera so that the camera will record the situation and the firemen can monitor it from control room.

A headset with full color display.

A mission control centre.

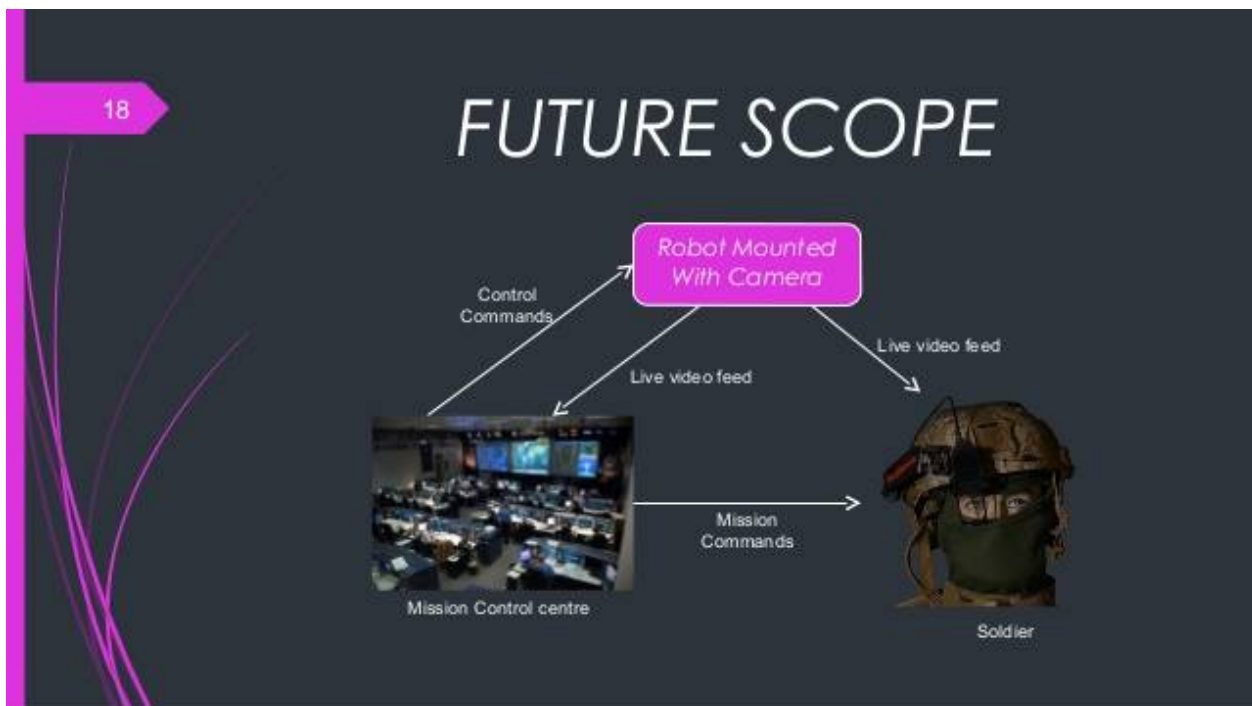

VIII. CONCLUSION

Integrating all the hardware such as fire extinguishing tasks are possible to be carried out and executed with minimum level of error. It aids to share out the burden of fire-fighters in fire fighting tasks as the fire-fighters can safely handover the fire fighting tasks to robot. Project aims to promote technology innovation to achieve a reliable and efficient outcome. Mobile robot that can move through a model structure, find fire and extinguish it. The movement of the robot is controlled by the sensors which are fixed on the mobile platform. It is to provide security of home, laboratory, office, factory and building is important to human life. We develop an intelligent multisensory based security system that contains a fire fighting system in our daily life. We design the fire detection system using sensors in the system, and program the fire detection and fighting procedure using sensor based method.

International Journal of Innovative Research in Science, Engineering and Technology

(An ISO 3297: 2007 Certified Organization)

Vol. 5, Issue 5, May 2016

REFERENCES

- [1] W. Budiharto, *Membuat Robot Cerdas*, Jakarta: Gramedia, 2006.
- [2] Ratnesh Malik, "Fire Fighting Robot : An Approach" , Indian Streams Research Journal Vol.2, Issue.II/March; 12pp.1-4
- [3] Kristi Kosasih, E. Merry Sartika, M. Jimmy Hasugian, dan Muliady, "The Intelligent Fire Fighting Tank Robot" , Electrical Engineering Journal, Vol. 1, No. 1, October 2010
- [4] H. P. Singh, Akanshu Mahajan, N. Sukavanam, Veena Budhraj, "Control Of An Autonomous Industrial Fire Fighting Mobile Robot", DU Journal of Undergraduate Research and Innovation
- [5] Swati A. Deshmukh, Karishma A. Matte and Rashmi A. Pandhare, "Wireless Fire Fighting Robot", International Journal For Research In Emerging Science and Technology
- [6] Lakshay Arora, Prof. Amol Joglekar, "Cell Phone Controlled Robot with Fire Detection Sensors", (IJCSIT) International Journal of Computer Science and Information Technologies, Vol. 6 (3) , 2015, 2954-2958
- [7] Arpit Sharma, Reetesh Verma, Saurabh Gupta and Sukhdeep Kaur Bhatia, "Android Phone Controlled Robot Using Bluetooth", International Journal of Electronic and Electrical Engineering. ISSN 0974-2174, Volume 7, Number 5 (2014), pp. 443-448
- [8] Saravanan P, "Design and Development of Integrated Semi - Autonomous Fire Fighting Mobile Robot", International Journal of Engineering Science and Innovative Technology (IJESIT) Volume 4, Issue 2, March 2015
- [9] Poonam Sonsale, Rutika Gawas, Siddhi Pise, Anuj Kaldate , "Intelligent Fire Extinguisher System", IOSR Journal of Computer Engineering (IOSR-JCE) e-ISSN: 2278-0661, p- ISSN: 2278-8727 Volume 16, Issue 1, Ver. VIII (Feb. 2014), PP 59-61 www.iosrjournals.org
- [10] Phyto Wai Aung, Wut Yi Win, "Remote Controlled Fire Fighting Robot", International Journal of Scientific Engineering and Technology Research Volume.03, IssueNo.24, September-2014