

Implementation of Audio Signal processing Application using TMS320C6713

Aaditi Hatekar¹, Karishma Gedam², Payal Dhomane³, Sheetal Wankhede⁴, Prof. Raman Bondare⁵,
Prof. Shraddha Raut⁶

U.G. Student, Department of ETC, Priyadarshini J.L. College of Engineering, Nandanvan, Maharashtra, India¹

U.G. Student, Department of ETC, Priyadarshini J.L. College of Engineering, Nandanvan, Maharashtra, India²

U.G. Student, Department of ETC, Priyadarshini J.L. College of Engineering, Nandanvan, Maharashtra, India³

U.G. Student, Department of ETC, Priyadarshini J.L. College of Engineering, Nandanvan, Maharashtra, India⁴

Assistant Professor, Department of EN, Priyadarshini J.L. College of Engineering, Nandanvan, Maharashtra, India⁵

Assistant Professor, Department of EN, Priyadarshini J.L. College of Engineering, Nandanvan, Maharashtra, India⁶

ABSTRACT: As communication plays an important role in day today life, the effective and efficient voice transmission is to be maintained. This paper mainly deals with voice transmission over a channel and implemented using 6713 DSK. In this project we have implemented BPSK for voice data Transmission by using the Texas Instruments TMS320C6713 DSP processor. TMS320C6713 is a 32-bit floating point DSP processor which is one of the Texas TMS320C6x family. Digital signal processors such as the TMS320C6x (C6x) family of processors are like fast special-purpose microprocessors with a specialized type of architecture and an instruction set appropriate for signal processing. The architecture of the C6x digital signal processor is very well suited for numerically intensive calculations.

KEYWORDS: BPSK, TMS320C6713, Voice Transmission, CCS Studio.

I. INTRODUCTION

A digital communication system is more reliable than an analog one because of the various digital signal processing algorithms that have been developed over the years. Hence, a major transition from analog to digital modulation techniques has occurred. Out of the various Digital Modulation techniques BPSK is one of the simplest, most robust of all the PSK techniques as it takes the highest level of noise or distortion to make the demodulator reach an incorrect decision. This paper explains in detail the digital Communication system and BPSK modulation and demodulation. .The BPSK modulation and demodulation is designed using Code Composer Studio.[1]

This paper deals with voice transmission over a channel. For this purpose, some modulation schemes and voice coders are to be implemented. Voice coding and transmission is an important and pervasive task in any telecommunication system. A simple transmission/reception scheme intended for voice transmission is proposed in the figure below consisting of: one microphone, a DSP board for voice acquisition, sampling, coding and modulation, a channel emulator, a second DSP board for voice processing or signal decoding, demodulation and voice reconstruction, a loudspeaker, and finally two PCs that control each DSP.[2]

International Journal of Innovative Research in Science, Engineering and Technology

(An ISO 3297: 2007 Certified Organization)

Vol. 5, Issue 5, May 2016

II. LITERATURE SURVEY

There are number of references used to determine the audio signal processing given in references. First paper mainly deals with voice transmission over a channel and implemented using 6713 DSK[1]. Second paper explains the detail of the digital Communication system and BPSK modulation and demodulation[2]. This study gives the information about digital communication[3]. This paper gives solution to this problem which allows for multiple modulation types and pulse shapes by applying the flexibility of digital signal processing (DSP) to the generation communication signals[4].

III. DIGITAL COMMUNICATION SYSTEM

The digital communication is the transmission of information in digital form from source to destination. In the analysis and design of communication system the characteristic of the channel affect the design of the basic building blocks. Figure 1 shows the functional diagram and basic elements of digital communication system. The source output may be either an analog signal such as an audio or video signal or a digital signal. The source encoder converts the either an analog or digital source into a sequence of binary digits called as source encoding or data compression. The channel encoder introduces in a controlled manner some redundancy to the binary information to overcome the effects of noise and interference while the transmitting the signal through the channel. The digital modulator maps the binary information sequence into signal waveforms since all the communication channels are capable of transmitting electrical signals.

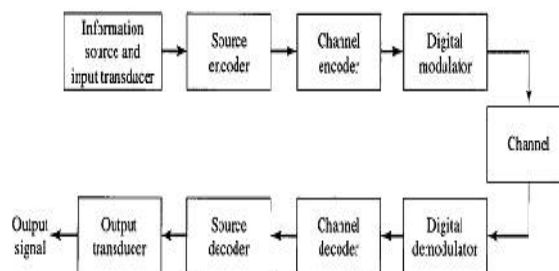

Figure 1: Block Diagram of Digital Communication

The communication channel may be wireless transmission or telephone channels including wire lines, optical fiber cables with variety of physical media which transmit signal from transmitter to receiver. The digital demodulator processes the channel corrupted transmitted waveform and reduces the Waveform to a sequence of numbers. [2]

IV. BINARY PHASE SHIFT KEYING

Digital modulation is a process in which one of the characteristics of the carrier signal is varied according to the data to be transmitted so that it is compatible with characteristics of the channel. The BPSK modulation technique is simplest and most robust of all PSK modulation techniques since it takes the highest level of noise or distortion to make the demodulator reach an incorrect decision. It is, however, only able to modulate at 1 bit/symbol and so is unsuitable for high data-rate applications. BPSK is a modulation technique in which the phase of the carrier signal is varied according to the modulating signal. In BPSK modulation the output of logic 0 is phase shifted to the output for logic 1. [2]

TRANSMITTER:

Consider a sinusoidal carrier. If it is modulated by a bi-polar bit stream according to the scheme illustrated in Figure 1 below, its polarity will be reversed every time the bit stream changes polarity. This, for a sine wave, is equivalent to a phase reversal (shift). The multiplier output is a BPSK signal.

International Journal of Innovative Research in Science, Engineering and Technology

(An ISO 3297: 2007 Certified Organization)

Vol. 5, Issue 5, May 2016

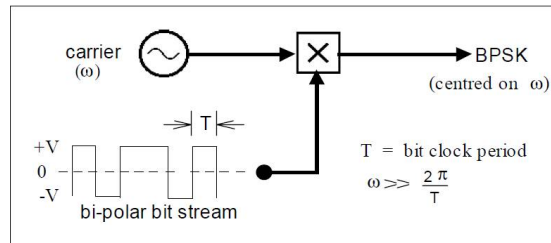

Figure 2: Generation of BPSK.

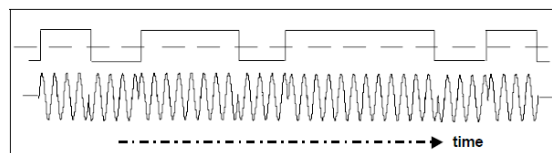

Figure 3: A BPSK signal in the time domain.

RECEIVER:

Demodulation of a BPSK signal can be considered a two-stage process.

1. Translation back to baseband, with recovery of the band limited message Waveform.
2. Regeneration from the band limited waveform back to the binary message bit stream.

The microphone records the speech data to be transmitted; while the main purposes of the transmitter are to encode the speech to minimize its bit rate, and modulate the data in such a way as to produce electromagnetic signals that can be transmitted across the channel. The channel transmits the signal. Regarding the receiver, the output of the channel is first synchronized, and then the influence of the channel over the signal is estimated to correct the errors of the received data. Finally, the data is demodulated and decoded, and the reconstructed speech displayed by a loudspeaker.

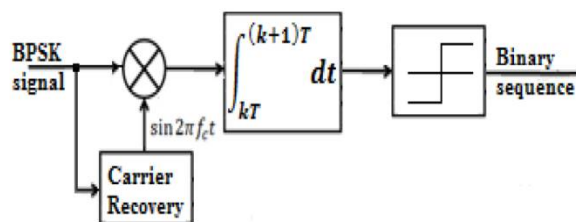

Figure 4: BPSK Demodulator

The sequence of BPSK coding technique explains clearly the BPSK is a digital modulation technique that separates bits by shifting the carrier 180 degrees. A carrier frequency signal is chosen that is known by both the transmitter and the

International Journal of Innovative Research in Science, Engineering and Technology

(An ISO 3297: 2007 Certified Organization)

Vol. 5, Issue 5, May 2016

receiver. Each bit is encoded as a phase shift in the carrier at some predetermined period. When a 0 is sent, the carrier is transmitted with no phase shift, and when a 1 is sent, the carrier is phase-shifted by 180 degrees.

V. OVERVIEW OF TMS320C6713 DSK KIT

DSP processors are concerned primarily with real-time signal processing. Real time processing requires the processing to keep pace with some external event, whereas non-real-time processing has no such timing constraint. The external event to keep pace with is usually the analog input. Whereas analog-based systems with discrete electronic components such as resistors can be more sensitive to temperature changes, DSP based systems are less affected by environmental conditions. DSP processors enjoy the advantages of microprocessors. They are easy to use, flexible, and economical. Digital signal processors such as the TMS320C6713 is like fast special-purpose microprocessors with a specialized type of architecture and an instruction set appropriate for signal processing.[4]

A. TMS320C6713 DSK:

The C6713 DSK is a low-cost standalone development platform that enables users to evaluate and develop applications for the TI C67xx DSP family. The DSK also serves as a hardware reference design for the TMS320C6713 DSP. Schematics, logic equations and application not are available to ease hardware development and reduce time to market. [4]

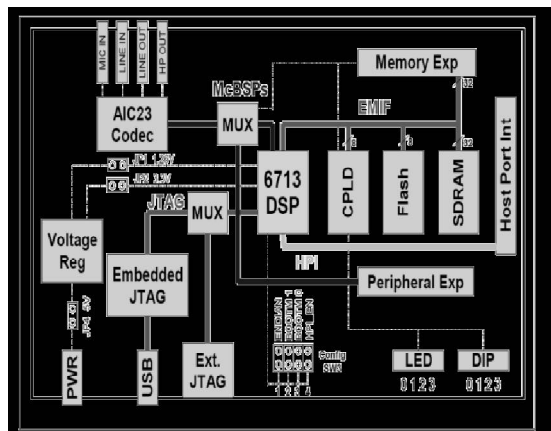

Figure 5:TMS320C6713 DSK Kit.

B. Code Composer Studio (CCS):

CCS provides an IDE to incorporate the software tools. CCS includes tools for code generation, such as a C compiler, an assembler, and a linker. It has graphical capabilities and supports real time debugging. It provides an easy-to-use software tool to build and debug programs. [4]

VI. EXPERIMENTAL RESULTS

CCS Component:

BPSK_sim.c is the C source program that modulates a bit stream of 10 bits set in the program. Since there is no carrier synchronization, demodulation is performed by the same program on the same DSK board. Building this project as **BPSK_sim** and connecting the DSK output to the input the demodulation of the transmitted sequence is verified. The demodulator program prints the demodulated sequence within CCS. This sequence is the same as the sequence set in the array encode sequence to be encoded.

International Journal of Innovative Research in Science, Engineering and Technology

(An ISO 3297: 2007 Certified Organization)

Vol. 5, Issue 5, May 2016

The array buffer stores the entire received vector that can be plotted within CCS. Select *View* → *Graph* → *Time/Frequency*. Use buffer as the address, 190 as the acquisition and display size, 8000 as the sample rate, and a 16-bit signed integer format. Figure 6a shows the CCS plot of the received sequence: {1, 0, 1, 1, 0, 0, 1, 0, 1} as set in the program. When the received sequence changes from a 0 to a 1 or from a 1 to a 0, a change of phase is indicated in the positive and negative y axis, respectively. Similarly Figure 6b indicates the CCS plot of the received sequence {0, 1, 0, 0, 1, 1, 1, 0, 1, 0} as encoded in the program. [5]

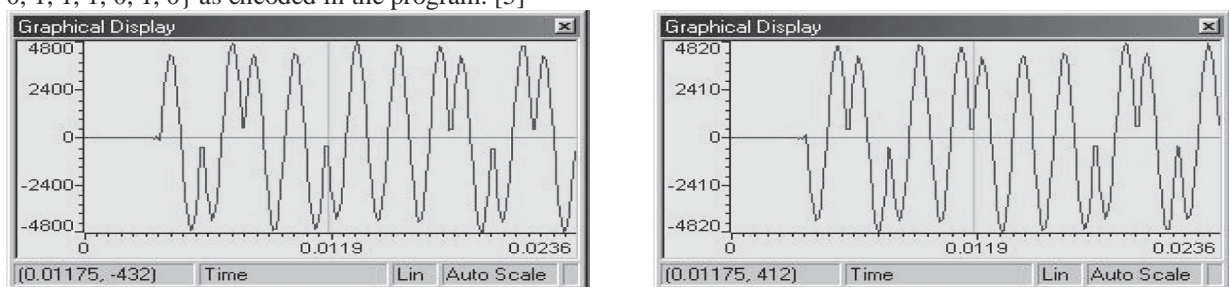

Figure 6: CCS plot of a received sequence, representing a BPSK modulated signal (a) sequence of {1, 0, 1, 1, 0, 0, 1, 0, 1} and (b) sequence of {0, 1, 0, 0, 1, 1, 1, 0, 1, 0}.

MATLAB Component:

The MATLAB program `BPSK_sim.m` simulates the modulation and demodulation of a random bit stream. After running this MATLAB file the plots in Figures 6a and 6b for signal-to-noise ratios (SNRs) of 0.5 and 5.0, respectively are verified. They display the transmitted and received waveforms of a random bit stream. The SNR can be changed in the program. The MATLAB program also displays the decision regions and detection, as shown in Figures 7a and 7b, for SNRs of 0.5 and 5.0, respectively. With small values of SNR, the received signals fall outside the appropriate decision regions, resulting in errors in detection. The received signal is noisier, resulting in some false detection. This occurs when the correlator produces an incorrect phase for the incoming symbol. Correct detections are marked with blue 'x's and incorrect detections with red circles. For larger values of SNR, there are no false detections and the correlated signals lie well within the detection region. [5]

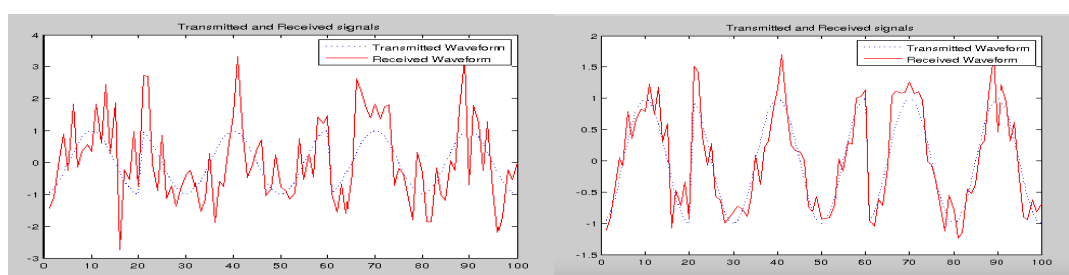

Figure 7: MATLAB plots simulating the modulation of a random bit stream showing the transmitted and received waveforms for (a) SNR = 0.5 and (b) SNR = 5.0.

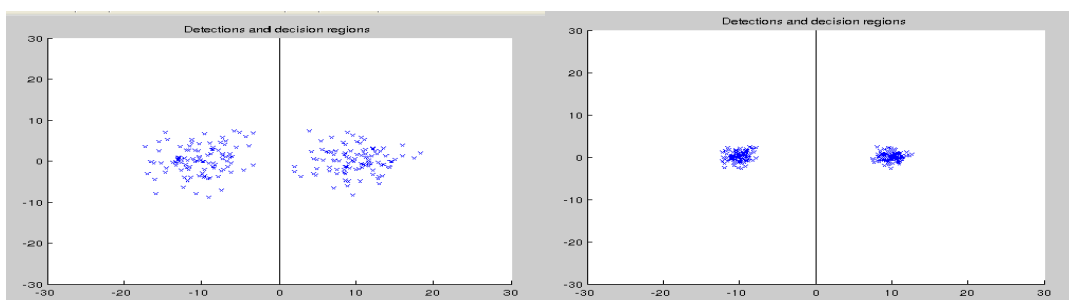

Figure 7: MATLAB plots displaying decision regions and detection for (a) SNR = 0.5 and (b) SNR = 5.0.

International Journal of Innovative Research in Science, Engineering and Technology

(An ISO 3297: 2007 Certified Organization)

Vol. 5, Issue 5, May 2016

VII. CONCLUSION

Now days there are many situations to keep voice secret in voice communication. This can be achieved by voice encryption by using different encryption algorithms. In this paper we have implemented BPSK on TMS320C6713 DSK for data transmission.

BPSK is a symmetric key algorithm means it uses the same key for transmission and reception. In this paper we have done simulations in both MATLAB and in the code composer studio version 3.1. In this paper we have used TMS 320C6713 DSK for real time implementation. It is a 32-bit floating point processor. In this paper we have presented the results in MATLAB and in CCS 3.1. [6]

REFERENCES

- [1] Sashi Kanth. B, Durgarao.J, Anand Kumar.G, Sasibala.P, "Implementation of a Modem for Narrow Bandwidth Channel Using 6713 DSK", International Journal of Communication Network and Security (IJCNS), Vol-1, Issue-3 ISSN: 2231-1882, pp.54-57, 2009.
- [2] Ms. Shruti Helonde & Prof. M. S. Pawar, "BPSK Modulation Technique for Digital Communication", International Journal of Advanced Technology & Engineering Research (IJATER), ISSN No: 2250-3536, pp.52-54, E-ICETT 2014.
- [3] "Digital Communications", John G. Proakis, Masoud Salehi, McGraw-Hill, 2008.
- [4] Dipti A. Pate, Hardik N. Mewada, "DSP Based Laboratory System for Exploring Communication Engineering Concepts", IJSRD - International Journal for Scientific Research & Development| Vol. 1, Issue 11, 2014 | ISSN (online): 2321-0613, pp.2406-2407, 2014.
- [5] Rulph Chassaing, Donald Reay, "Digital Signal Processing and Applications with the TMS320C6713 and TMS320C6416 DSK", Second Edition.
- [6] B. Rajesh, "Real Time Implementation of DES Algorithm by using TMS3206713 DSK", Department of Electronics and Communication Engineering National Institute Of Technology Rourkela 2008.
- [7] Texas Instruments Tutorial, "TMS320C6713 Floating-Point Digital Signal Processor", (December 2001 – Revised November 2005), SPRS186L.
- [8] Texas Instruments Tutorial, "TMS320 DSP Product Family Glossary", (February 1998), SPRU258A.
- [9] Texas Instruments Tutorial, "Code Composer Studio Development Tools v3.2 Getting Started Guide", (March 2006), SPRU509G.
- [10] Texas Instruments Tutorial, "TMS320C6000 Instruction Set Simulator Technical Reference Manual", (April 2007), SPRS600I.
- [11] Texas Instruments Tutorial, "How to Begin Development Today With the TMS320C6713 Floating-Point DSP", (October 2002), SPRA809A.
- [12] Texas Instruments Tutorial, "TMS320C6713 Hardware Designer's Resource Guide", (July 2004), SPRAA33.
- [13] "Audio Content-Based Feature Extraction Algorithms Using J-DSP for Arts, Media And Engineering Courses", Mohit Shah, Gordon Wichern, Andreas Spanias and Harvey Thornburg School of ECEE, SenSIP Center, Arizona State University.