

# Design and Analysis of an Internal Combustion Engine Piston Head to Increase the Torque on Crankshaft

Nagasundaram.S<sup>1</sup>, Nester Ruban.J<sup>2</sup>M.E. CAD/CAM Engineering, Department of Mechanical Engineering, JJ College of Engineering and Technology,  
Tiruchirappalli, Tamil Nadu, India<sup>1</sup>Assistant Professor, Department of Mechanical Engineering, JJ College of Engineering and Technology,  
Tiruchirappalli, Tamil Nadu, India<sup>2</sup>

**ABSTRACT:** The in-cylinder air motion in internal combustion engines is one of the most important factors controlling the combustion process combustion efficiency of CI engine and emissions especially NO<sub>x</sub> can be controlled by creating turbulence, by designing intake system, by designing combustion chamber. A good swirl promotes fast combustion to improve the efficiency. So in the present work a study about the influence of air swirl in the combustion chamber upon the performance and emission of a diesel engine is studied. The intensification of the swirl is studied on the crown of the piston by three different configurations of Models are, Mitsubishi, Pan and Shallow Hasselman. CFD analysis is carried out on a diesel engine using different configuration pistons which is four stroke engine cylinder air cooled and constant speed. Performance parameters such as turbulent kinetic energy and turbulent intensity and turbulent dissipation are calculated. CREO is parametric used for design and Ansys IC Engine Solver 15.0 is used for analysis.

**KEYWORDS:** IC Engine, Piston Head, Air Swirl, Turbulent, CREO, Ansys 15.0 IC Engine Solver.

## I.INTRODUCTION

Internal combustion engines have been relatively inexpensive and reliable source of power for application ranging from domestic use to large scale industrial and transportation applications for most of the twentieth century. DI Diesel engines, having the evident benefit of the higher thermal efficiency than all other engines, have served for both Light-Duty and Heavy-Duty Vehicles.

The in-cylinder fluid motion in the internal combustion engines is one of the most important factors controlling the combustion process. It governs the fluid-air mixing and burning rates in Diesel engines. The fluid flow prior to combustion in internal combustion engines is generated during the induction process and development during the compression stroke (Xuelinag and shusong, 1990; and shaoxi and Wanhua, 1990).Therefore, a better understanding of fluid motion during the induction process is critical for developing engine designs with the most desirable operating and emission characteristics (Wu zhijun and Huang Zhen, 2007).

To obtain a better combustion with lesser emission in direct-injection diesel engines, it is necessary to achieve a god spatial distribution of the injected fuel throughout theentire space (Arturo de Risietal., 2003). This requires matching of the fuel sprays with combustion chamber geometry to effectively make use of the gas flows. In other words, matching the combustion chamber, fuel injection and gas flows in the most crucial factors for attaining a better combustion (Herbert schapertons and Fred Thiele, 1986). In DI Diesel engines, swirl can increase the rate of fuel-air mixing (Corcioneet al, 1993), reducing the combustion duration for re-entrant chambers at retarded injection timings.

# International Journal of Innovative Research in Science, Engineering and Technology

(An ISO 3297: 2007 Certified Organization)

Vol. 5, Issue 5, May 2016

Swirl interaction (Ogawa et al, 1996) with compressed induced squish flow increases turbulence level in the combustion bowl, promoting mixing. Since the flow in the combustion chamber develops from interaction of the intake flow with the in-cylinder geometry, the goal of this work is to characterize the role of combustion chamber geometry in-cylinder flow, thus the fuel-air mixing, combustion and pollutant formation processes. It is evident that his effect of geometry has a negligible effect on the airflow during the intake stroke and early part of the compression stroke. But the piston moves towards Top Dead center (TDC), the bowl geometry has a significant effect on airflow thereby resulting in better atomization, better mixing and better combustion. The re-entrant chamber without central projection with sharp edges provides higher swirl number than all other chambers (Gunabalan and Ramaprabhu, 2009).

## II. INFLUENCE OF AIR MOTION IN COMBUSTION CHAMBER

To enhance the efficiency of the engine it is important to optimize thermal efficiency, which is obtained at highest possible compression ratio. However, if the compression ratio is too high, there is a chance to have knock, which should be avoided at all cost. A solution for the problem is to promote rapid combustion, to reduce the time available for the self-ignition to occur (Jorge martin's et al., 2009). To promote rapid combustion, sufficient large-scale turbulence (Kinetic Energy) is needed at the end of the compression stroke because it will result in a better mixing process of air and fuel it will also enhance flame development.

However, too much turbulence leads to excessive heat transfer from the gases to the cylinder walls, and may create problem on flame propagation (Stone, 1989; Blair, 1999; and Lumley, 2001). The key to efficient combustion is to have enough swirl in the combustion chamber prior to ignition. In order provide complete combustion at a constant rate, there is common design objective of bringing sufficient air in contact with the injected fuel particles. For this purpose, the piston crown and the cylinder head are shaped to induce the swirling motion to air while moving compression piston is moving towards TDC.

The production of Turbulence, i.e., swirl by different means, however, is considered necessary for better fuel-air mixing. The complexities of productions and higher cost of this methods of creating turbulence of the limiting factors in their wider use. An increase in air swirl level is noted to increase the air mass of all zones. Thus at the moment when the mixture first ignites in one zone, all other zones approaching their self-ignition temperature contain more air. Increased swirl results in an increase in initial combustion rate and hence higher rate of pressure rise is expected (Payriet al, 1990).

The swirl can be generated in the diesel engine by modifying three parameters in the engine they are the cylinder head, the piston, i.e, modification of combustion chamber and the inlet manifold (Lin and Ogura, 1995). Somendersingh (2001) has invented the multi impingement wall head is located at the center of the cylinder head to enhance the swirl and squish. Somendersingh is identified a method to improve turbulence I combustion chamber b making grooves on the cylinder head, to reduce the heat losses; the burn time needs to be as quick as possible. According to Ammar Al-Rousan (2008) swirl is generated in the inlet manifold by inserting the loop inside the intake manifolds to increase the swirling in the air during induction. Rasul and Glasgow (2005) prepared a convergent-divergent induction nozzle and is tested in order to increase the airflow into the engine, which may increase overall performance. Prasad et al. (2011a and 2011b) and prasad and pandupangadu (2013) experimentally investigation on influence of the air swirl in the cylinder upon the performance and the emission of the single cylinder diesel direct injection engine is presented. In order to achieve the different swirl intensities in the cylinder, three design parameters have been changed the cylinder head, piston crown, and inlet duct, in this way the piston crown is modified, i.e., alteration of combustion chamber to enhance the turbulence in the cylinder. This intensification f the swirl is done by cutting grooves on the crown of the piston. Performed experimentally different configurations of piston, i.e., I the order grooves intensify the swirls for better mixingof fuel and air and their effects on the performance and emissions.

# International Journal of Innovative Research in Science, Engineering and Technology

(An ISO 3297: 2007 Certified Organization)

Vol. 5, Issue 5, May 2016

## III. ENGINE EFFICIENCY

Once ignited and burnt, the combustion products—hot gases—have more available thermal energy than the original compressed fuel-air mixture (which had higher chemical energy). The available energy is manifested as high temperature and pressure that can be translated into work by the engine. In a reciprocating engine, the high pressure Gases inside the cylinders drive the engine's pistons.

Once the available energy has been removed, the remaining host gases are vented (often by opening a valve or exposing the exhaust outlet) and this allows the piston in to the previous position (top Dead center, or TDC). This piston can then proceed to the next phase of its cycle, which varies between engines. Any heat that is not translated in to work is normally considered a waste product and is removed from the engine either by an air or liquid cooling system.

Internal combustion engines are primarily heat engines, and as such their theoretical efficiency is calculated by idealized thermodynamic

Cycles. The efficiency of the theoretical cycle cannot exceed that of the Carnot cycle, whose efficiency is determined by the difference between the lower and upper operating temperatures of the engine. The upper operating of the terrestrial engine is limited by the thermal stability of the materials used to construct it. All metal and alloys are eventually melt or decompose, and there is significant researching into ceramic materials that can be made with greater thermal stability and desirable structural properties. Higher thermal stability allows for greater temperature difference between lower and upper operating temperatures, hence greater thermodynamic efficiency.

The thermodynamic limits assume that the engine is operating under ideal conditions: a frictionless worlds, ideal gases, perfect insulators, and operations for infinite times. Real world applications introduce complexities that reduce efficiency. For example, a real engine runs best at a specific load, termed its power band.

The engine in a car cruising on a highway is usually operating significantly below its ideal load, because it is designed for higher loads required for rapid acceleration. In addition, factors such as wind reduce overall system efficiency. Engines fuel economy is measured in miles per gallon or in liters per 100 kilometers. The volume of hydrocarbon assumes a standard energy content.

Most steel engines having a thermodynamic limit of 37%. Even when aided with turbochargers and stock efficiency aids, most engines retain an average energy of about 18%-20%.

Rocket engine efficiency are much better, at 70%, because they operates at very high temperatures and pressures and can have very high expensive ratios. Electric motors are better still, at around 85-90% efficiency or more, but they rely on an external power source (often another heat engine at a power plant subject to similar thermodynamic efficiency limits).

There are many inventions aimed at the increase the efficiency of IC engines. In general, practice engines are always compromised by trade-offs between different properties such as efficiency, weight, power, heat, response, exhaust, emissions, or noise. Sometimes economy plays a role in not only the cost of manufacturing and engine itself, but also manufacturing and distributing the fuel. Increasing the engine's efficiency brings better fuel economy but only if the fuel cost per energy content is the same.

## IV. COMBUSTION SECTOR METHOD IN ANSYS CFD SOFTWARE

The combustion method is analyzed between TDC to BDC. In this paper design is done through the Creo parametric software.

# International Journal of Innovative Research in Science, Engineering and Technology

(An ISO 3297: 2007 Certified Organization)

Vol. 5, Issue 5, May 2016

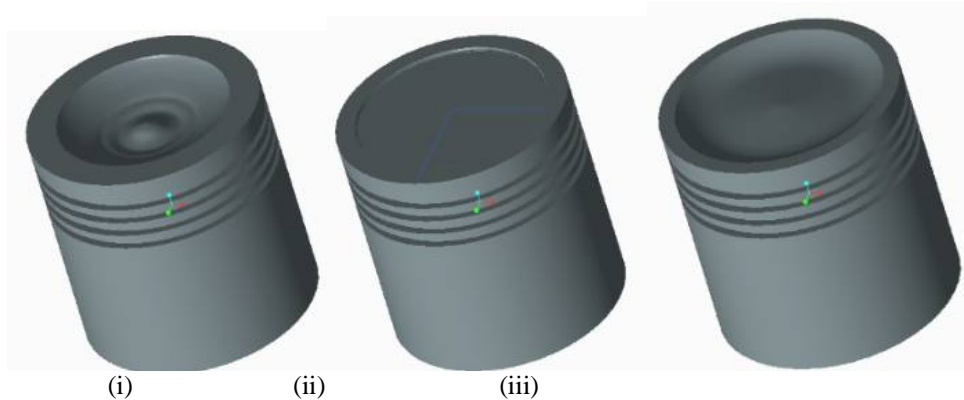

Fig 1: Types of piston

Types of piston

- i. Pan
- ii. Mitsubishi
- iii. Shallow Hasselman

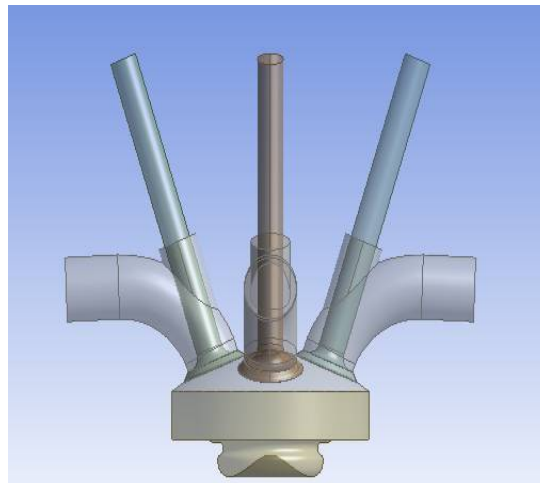

Fig 2: Sector Method geometry for model AVL (TDC to BDC)

## Specification of the engine used for analysis in Ansys IC Engine Solver

Analysis type= ICE (Sector type combustion method)  
Engine Type = Diesel Engine  
Number of Crank Angle to run = 263  
RPM = 1500  
Connecting rod length = 320

# International Journal of Innovative Research in Science, Engineering and Technology

(An ISO 3297: 2007 Certified Organization)

Vol. 5, Issue 5, May 2016

Crank Radius = 40  
Minimum Lift = 0.2  
IVC = 570  
EVO = 833  
Minimum Spray Length = 0.02  
Spray Angle = 70 degree  
Combustion Mixture  
O<sub>2</sub> = 0.232  
CO<sub>2</sub> = 0.00046  
H<sub>2</sub>O = 5e<sup>-7</sup>  
Total flow rate = 0.10 Kg/sec

Other specification are default value in IC Engine Solver. We can change them as per our convenience of Analysis

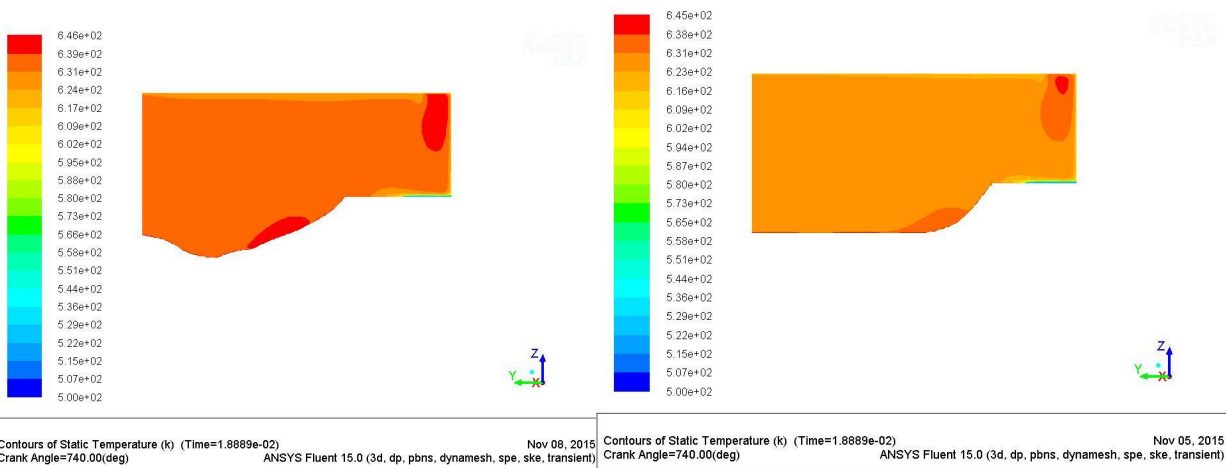

Fig 3: CFD result for model Mitsubishi at CA 740

Fig 4: CFD Result for model Pan at CA 740

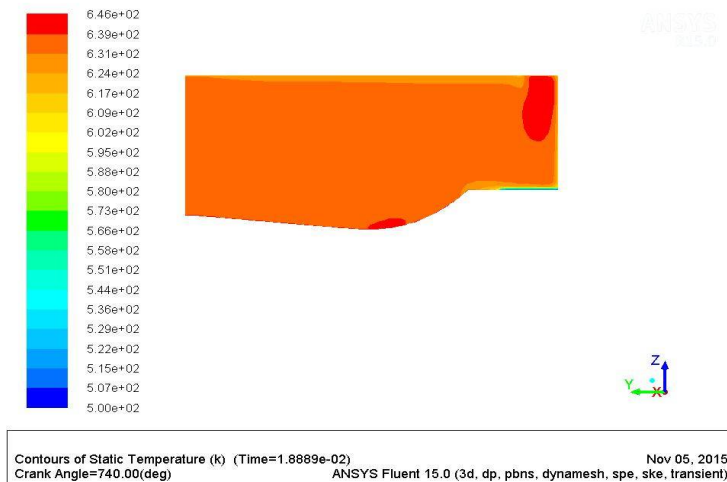

Fig 5: CFD result for model Shallow Hasselman at CA 740

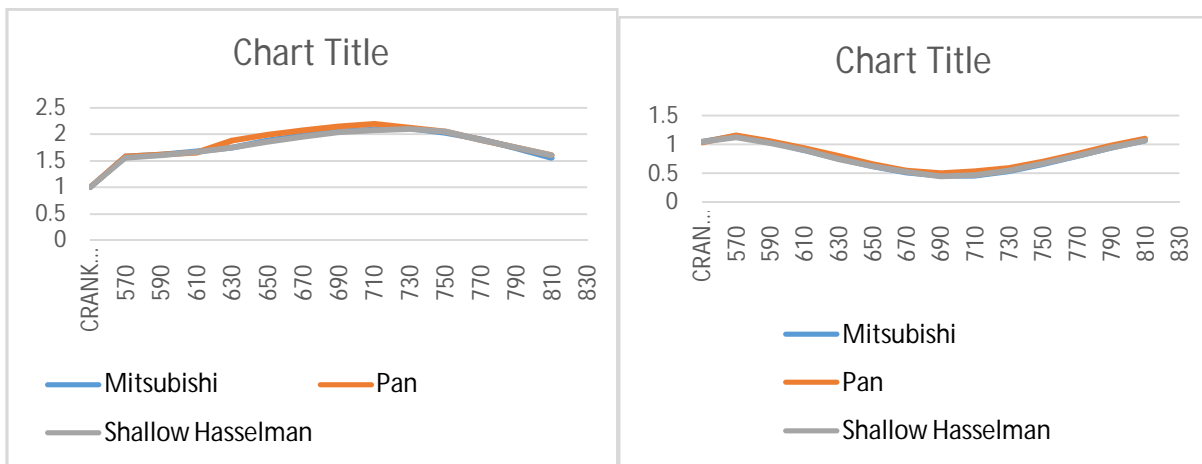

Fig 9: Turbulent kinetic Energy

Fig 10: Turbulent intensity

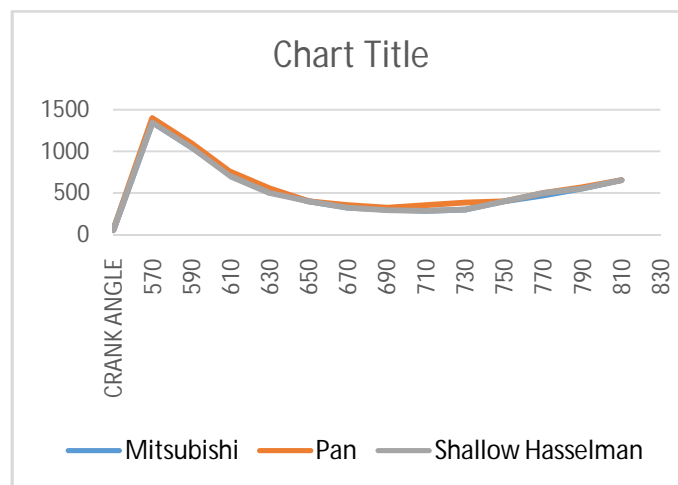

Fig 11: Turbulent dissipation Result

## V. RESULT

The results for the modified pistons are taken from the Computational Fluid Dynamics Analysis. The calculated swirl ratio is 1.3. The results are taken and compare between 6 pistons to get the better modified model. Combustion sector method is done at IC Engine Solver Ansys Software. From the CFD Result we can assure that the model Pani is Efficient than other 2 models. The turbulence is increased compared to other models results better burning of fuel during the combustion operation in IC Engine Piston. Normally Fuel burning ratio is between 70 to 80 percentages. The higher ratio gives us the good fuel burning efficiency.

Due to the burning efficiency there is high combustion rate in the internal combustion engine. When the combustion is increased the speed of the piston stroke is increased which results in increase of torque on Crank Shaft.

# International Journal of Innovative Research in Science, Engineering and Technology

*(An ISO 3297: 2007 Certified Organization)*

**Vol. 5, Issue 5, May 2016**

So the modified model Pan is consider as good and efficient model but the solution also want to analysis the model practically to justify. In this paper, CFD based experiments are concentrated.

## REFERENCES

- [1] Dr.S.L.V. Prasad, Prof V.Pandurangadu, Dr.P.Manoj Kumar, Dr G. Naga Malleshwara Rao (Enhancement Of Air Swirl In A Diesel Engine With Grooved Cylinder Head)
- [2] SanthoshKumar.G,Prof.K.Hema Chandra Reddy , Ch.Rajesh, G.Suresh Kumar(A Review On Study Of The Effect Of In Cylinder Air Swirl On Diesel Engine Performance And Emission)
- [3] R. C. Singh, Roop. Lal, Ranganath M S, Rajiv Chaudhary(A Review : Failure Of Piston In Ic Engine)
- [4] B.Madhubabu, Prof. K. Govindarajulu And Dr.S.L.V.Prasad (Experimental Investigation Of A Single Cylinder 4- Stroke Di Diesel Engine By Swirl Induction With Two Different Configuration Pistons)
- [5] Vaibhav Bhatt, VandanaGajjar (Experimental Investigation Of Performance And Exhaust Emission Characteristics Of Diesel Engine By Changing Piston Geometry )
- [6] J Paul Rufus Babu1, B MadhuBabu, T Dada Khalandar And P S Bharadwaj(Experimental Investigation Of Rhombus Shaped Grooves On Piston Crown Of A Single Cylinder 4-Stroke Di Diesel Engine).