

Design and Analysis of Helical Blade Wind Turbine

S.S.Suprajha^{*}, K.Vijayan[#]

PG Student, M.E CAD/CAM, Department of Mechanical Engineering, MAM College of Engineering and Technology, Trichy, Tamil Nadu, India^{*}

Associate Professor, Department of Mechanical Engineering, MAM College of Engineering and Technology, Trichy, Tamil Nadu, India[#]

ABSTRACT: This report describes about the wind power and its potential that can be harnessed in the future to meet the current energy demand. With detailed description of the wind turbine and the wind generator focus has been given on the interconnection of the generators with the grid and the problems associated with it. The shape of the blades is changed to helical so that it can rotate continuously at any direction of wind. Hence the efficiency of the turbine is improved and also the stresses are minimised. Conclusions were made about the behaviour of the wind in urban location. Thereafter, the helix angle of the blade is changed and the best angle of operation is analysed.

KEYWORDS: Energy demand, wind turbine, helical blade, helix angle.

I. INTRODUCTION

A windmill is a mill that converts the energy of wind into rotational energy (mechanical energy) by means of vanes called sails or blades. Centuries ago, windmills usually were used to mill grain, pump water, or both. Thus they often were gristmills, wind pumps, or both. The majority of modern windmills take the form of wind turbines used to generate electricity, or wind pumps used to pump water, either for land drainage or to extract groundwater. A wind turbine is a device that converts kinetic energy from the wind into electrical power. The term appears to have migrated from parallel hydroelectric technology (rotary propeller). The technical description for this type of machine is an airfoil-powered generator.

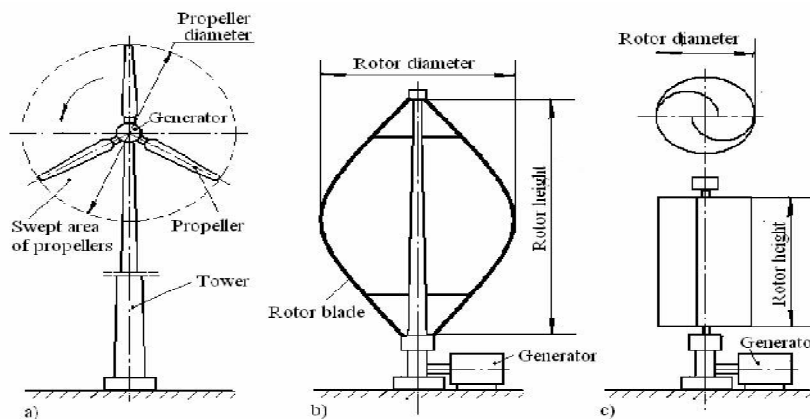

Fig. 1 Wind turbine configurations: (a) propeller type; (b) Darrieus; (c) Savonius.

International Journal of Innovative Research in Science, Engineering and Technology

(An ISO 3297: 2007 Certified Organization)

Vol. 5, Issue 5, May 2016

Types :-

- Horizontal Axis Wind Turbine
- Vertical Axis Wind Turbine

II. BRIEF DESCRIPTION OF THE DESIGN AND WORK OF THE HELICAL BLADE WIND TURBINE

Typically, helical wind turbines are designed along a vertical axis. Vertical axis wind turbines are generally gaining popularity for residences and urban settings because they can be placed lower to the ground and on rooftops. Another advantage of the helical wind turbine is that it generally can be used in areas with higher wind speeds where bladed turbines would need to be shut down for safety reasons. In recent years, manufacturers of utility scale horizontal axis bladed wind turbines have come under fire for killing birds especially in migratory paths. Helical wind turbines are also less susceptible to problems with crosswinds than bladed turbines and they require no tail-fan to keep them pointed in the optimal direction.

III. FEATURES

- The turbine is self-starting.
- They are omni directional and do not require pointing in the direction of the wind.
- The lower blade rotational speeds imply lower noise levels.
- Perceived as being more aesthetically pleasing.
- The increased blade configuration solidity and torque assists the machine in self-starting.
- Eliminating the risk of the blade reaching equilibrium during start-up rotation by using 3 blades or more.
- Reduced cyclic loading and power pulsation and fluctuation by using more than 2 blades.
- Easy access to all mechanical and structural elements of the machine.
- A direct drive, permanent magnet generator is used and there are no gear boxes with the machine having only one moving part.

IV. WIND TURBINE

1) Parts

- **Blades:** Most turbines have either two or three blades. Wind blowing over the blades causes the blades to "lift" and rotate.
- **Generator:** Direct drive, mechanically integrated, weather sealed 6kW permanent magnet generator. The gear box is a costly (and heavy) part of the wind turbine and engineers are exploring "direct-drive" generators that operate at lower rotational speeds and don't need gear boxes.
- **Rotor:** The blades and the hub together are called the rotor.

International Journal of Innovative Research in Science, Engineering and Technology

(An ISO 3297: 2007 Certified Organization)

Vol. 5, Issue 5, May 2016

2) Present operating condition

Parameter	Value	Unit
Rated Power	3	kW
Rotor Diameter	4	m
Rotor Height	4.2	m
Tower Height	4	m
Rated Wind Speed	12	m/s
Cut-In Speed	2	m/s
Cut-Out Speed	15	m/s
Rated Speed	230	rpm
Total Height	8.2	m
Weight	680	kg
Standard Operating Temperature	-10 – 40	°C

Table 1 Present Operating Condition

- Cut- in speed: The lowest wind speed at which a wind turbine begins producing usable power is called cut-in speed.
- Cut-out speed: The highest wind speed at which a wind turbine stops producing power is called cut-out speed.

V. BLADE

1) Type

1) The type of blade used is NACA 2412. NACA airfoils are [airfoil](#) shapes for aircraft wings developed by the [National Advisory Committee for Aeronautics](#) (NACA). The shape of the NACA airfoils is described using a series of digits following the word “NACA”. The parameters in the numerical code can be entered into equations to precisely generate the cross-section of the airfoil and calculate its properties.

The NACA four-digit wing sections define the profile by:

- First digit describing maximum [camber](#) as percentage of the [chord](#).
- Second digit describing the distance of maximum camber from the airfoil leading edge in tens of percents of the chord.
- Last two digits describing maximum thickness of the airfoil as percent of the chord.

The NACA 2412 airfoil has a maximum camber of 2% located 40% (0.4 chords) from the leading edge with a maximum thickness of 12% of the chord. Four-digit series airfoils by default have maximum thickness at 30% of the

International Journal of Innovative Research in Science, Engineering and Technology

(An ISO 3297: 2007 Certified Organization)

Vol. 5, Issue 5, May 2016

chord (0.3 chords) from the leading edge. The NACA 0015 airfoil is symmetrical, the 00 indicating that it has no camber. The 15 indicates that the airfoil has a 15% thickness to chord length ratio: it is 15% as thick as it is long.

2) Parts

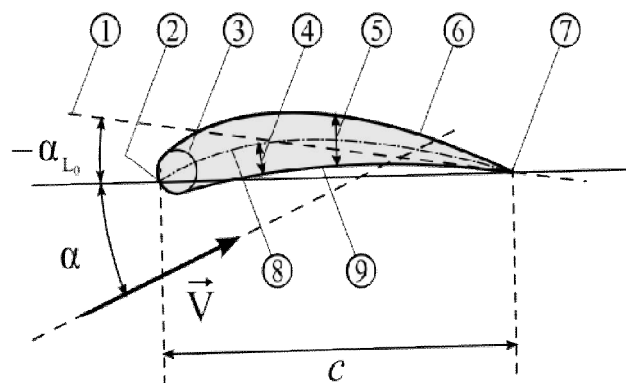

Fig. 2 Parts of an Airfoil

- 1 – zero lift line
- 2 – leading edge
- 3 – nose circle
- 4 – camber
- 5 – maximum thickness
- 6 – upper surface
- 7 – trailing edge
- 8 – main camber line
- 9 – lower surface
- c – chord

VI. PARAMETERS

1) Tip Speed Ratio

The tip speed ratio is very important. The tip speed ratio (λ) for wind turbines is the ratio between the rotational speed of the tip of a blade and the actual velocity of the wind. The tip speed ratio is directly proportional to the windmill's productivity. High efficiency 3-blade-turbines have tip speed of 6 to 7.

2) Betz Limit

No wind turbine could convert more than 59.3% of the kinetic energy of the wind into mechanical energy turning a rotor. This is known as the Betz Limit, and is the theoretical maximum coefficient of power for any wind turbine. The maximum value of C_p according to Betz limit is 59.3%. For good turbines it is in the range of 35 – 45%.

3) Material used

• Wind Turbine Blades

The latest blade design is made of fibre-glass and epoxy resin. Its unique feature is its curvature like tip which allows it to catch low wind speeds. The turbine blades made of carbon fibre are light weight, and has a razor sharp edge which allows it to literally cut through the wind and makes it almost silent. The material of the blade is glass fibre - epoxy resin. It is less expensive than carbon composite. Fibreglass composites are insulators, which mean they do not respond to an electric field and resist the flow of electric charge.

International Journal of Innovative Research in Science, Engineering and Technology

(An ISO 3297: 2007 Certified Organization)

Vol. 5, Issue 5, May 2016

Fiberglass might not have a higher tensile strength but has a dramatically lower tensile modulus. This allows it to bend and take more strain without breaking.

Parameter	Value	Unit
Tensile Strength	4137	MPa
Tensile Modulus	242	GPa

Table 2 Mechanical properties of glass fibre - epoxy resin

• Turbine

The turbine was made of Aluminium Alloy 1060-H18 because of its strength and light weight compared to other material that was used before. 1060 aluminium alloy is an aluminium-based alloy in the “commercially pure” wrought family (1000 or 1xxx series). It is fundamentally very similar to 1050 aluminium alloy, with the difference coming down to 0.1% aluminium by weight. However, while both 1050 and 1060 are covered by the same ISO standard, they are covered by different ASTM standards.

Parameter	Value	Unit
Elastic Modulus	69	GPa
Poisson's Ratio	0.33	-
Density	2705	kg/m ³
Shear Strength	75	MPa
Tensile Strength	130	MPa
Yield Strength	125	MPa
Fatigue Strength	45	MPa
Thermal Conductivity	230	W/mK
Specific Heat	900	J/kgK

Table 3 Mechanical Properties of Aluminium Alloy 1060-H18

VII. FORMULAE

$$P = 0.5\rho AV^3 C_p \quad (1)$$

$$P = \tau \omega \quad (2)$$

$$\tau = 0.5\rho V^2 Ar \quad (3)$$

$$\lambda = \frac{\omega r}{V} \quad (4)$$

Formula referred from the book “Wind Turbines – Fundamentals, Technology, Application, and Economics” written by “Erich Hau”.

1) Description

Ideally, power scales linearly with the area swept out by the turbine blades, and cubically with the speed of the wind as it contacts the blades. However, these relationships have some variation depending on the design of each particular turbine. The power coefficient at the end of the equation accounts for the efficiency of the

International Journal of Innovative Research in Science, Engineering and Technology

(An ISO 3297: 2007 Certified Organization)

Vol. 5, Issue 5, May 2016

turbine in converting the wind's kinetic energy into mechanical energy. The theoretical maximum power coefficient, or Betz limit, is 0.59. However, most wind turbines operate at a power coefficient of less than 0.45. Beyond that loss in efficiency, there are also small losses resulting from the gearbox, bearings, and generator. The power can also be estimated using the estimated torque and experimental data for the rotational speed of the rotor. For turbines which use drag forces (not lift forces), can be used to estimate the amount of torque in the system. By combining (2) and (3), the power generated experimentally can be compared to the predicted power generation from (1). This would approximate whether or not the predicted power efficiency was met. The tip speed ratio, λ , defines the relationship between blade tip speed and incident wind speed. The expression used to calculate it is shown in (4).

VIII. MODIFIED DESIGN

The support has 3 bars, each placed at a distance of 120° from its centre reference axis. There are 2 supports each placed at the top and bottom of the blades. The supports are connected to the inner shaft so that the rotational motion of the shaft is then converted to electrical energy. The blade is designed in a helical shape such that it is twisted to 120° . The twist starts at one bar of the upper support and ends in the adjacent bar of the lower support. The blade is made hallow to reduce unnecessary weights.



Fig. 4 Blade

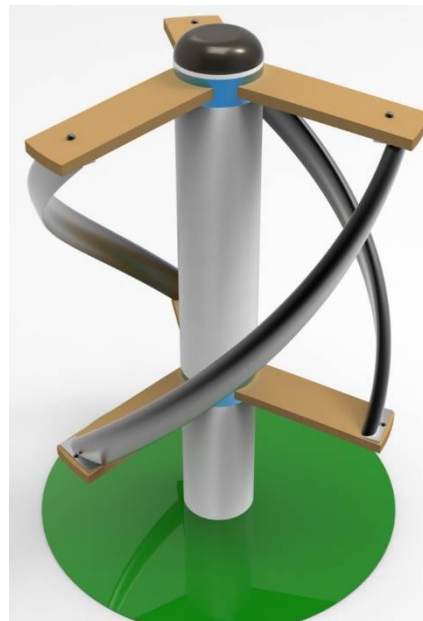

Fig. 5 Assembled setup

The base tower is just a support where the rotational setup is mounted on it. The minimum height of the base tower should be 3m. At the end of the tower generator and direct drives are placed. This is made hallow such that another shaft is placed inside for rotation. This is the fully assembled view of the wind turbine. The wind turbine rotates in any direction of wind. The 'Y' supports are supported by ball bearings. Also the inner shaft and the outer case are connected with few ball bearings with some spaces to reduce vibration of the shaft.

International Journal of Innovative Research in Science, Engineering and Technology

(An ISO 3297: 2007 Certified Organization)

Vol. 5, Issue 5, May 2016

Parameter	Value	Unit
Rated Power	5.74	kW
Rotor Diameter	3.1	m
Rotor Height	5	m
Cut-in Speed	2	m/s
Cut-out Speed	16	m/s
Total Height	8.16	m
Operating Temperature	-40 – 50	°C

Table 4 Values of modified design

IX. ANALYSIS

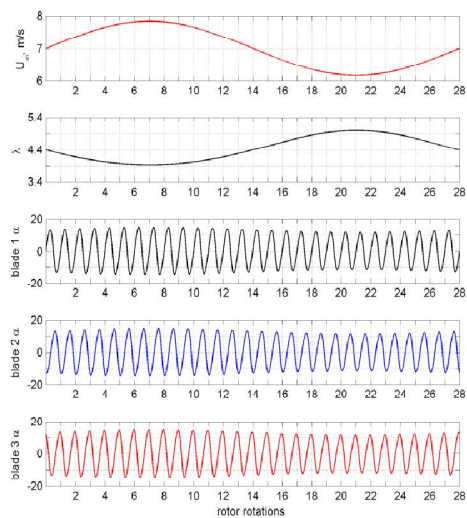

Fig. 6 Variation of U_{∞} , λ , and α

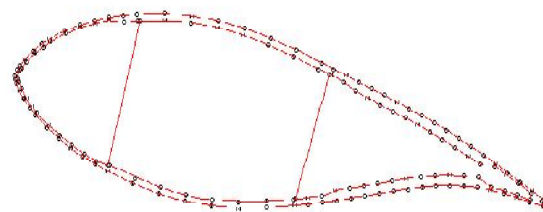

Fig. 7 Co-ordinates of airfoil

The mean wind speed is $U_{mean} = 7$ m/s with a 12% fluctuating amplitude of $U_{amp} = \pm 12\%$ (± 0.84 m/s) and fluctuation frequency of $f_c = 0.5$ Hz. The rotor angular speed is a constant $\omega = 88$ rad/s (840 rpm) resulting in a mean tip speed ratio of $\lambda_{mean} = 4.4$. When inspected against the steady C_p curve, this condition is just before peak performance at $\lambda^* = 4.5$. A total of 28 rotor rotations completes one wind cycle. As shown in Figure 7, the λ changes with the fluctuating U_{∞} . Increasing U_{∞} causes the λ to fall owing to their inverse relationship and a constant ω . Maximum U_{∞} is 7.84 m/s and occurs at the end of the 7th rotation with λ dropping to its minimum of 3.93. The maximum α of each blade per rotation can be seen to increase with the increasing U_{∞} reaching a peak value of $\alpha = 14.74^\circ$ between the 6th and 8th rotation depending on the blade considered. Following the maximum U_{∞} is the gradual drop of U_{∞} back to the mean wind speed. It continues to fall until it reaches the minimum value of $U_{\infty} = 6.16$ m/s at the end of the 21st rotation. At this U_{∞} , the λ rises to its maximum value at 5.0. Within this part of the wind cycle, the maximum α per rotation falls to 11.55° between the 20th and 22nd rotation depending on the blade in question. The subsequent increase of U_{∞} back to the mean value causes the λ to drop in magnitude and the peak α per rotation to increase.

X. NOMENCLATURE

- P – Extracted power from the wind (W)
- ρ – Air density (1.225 kg/m³)

International Journal of Innovative Research in Science, Engineering and Technology

(An ISO 3297: 2007 Certified Organization)

Vol. 5, Issue 5, May 2016

r	–	Rotor radius (m)
A	–	Swept area (m^2)
V	–	Wind velocity (m/s)
C_p	–	Power co-efficient (C_p) is defined as the ratio of the output power produced to the power available in the wind
τ	–	Torque (Nm)
ω	–	Rotational speed of the rotor (rad/s)

XI. CONCLUSION

These turbines are comparatively easy to build and the investment is also well affordable when compared to the HAWTs. Since the turbines are smaller in size, they can be only used for low power applications such as for powering streetlights or the toll plazas. Moreover, they may also be used to power the advertisement hoardings. An advantage is that they can catch wind from all directions eliminating the need for yaw mechanism. In addition, they can be built lower so they are less visible and can withstand much harsher environments and do not need to be shut down at greater wind speeds.

Using a validated CFD model, steady wind simulations at $U_\infty = 7\text{m/s}$ were conducted and results have shown a typical performance curve prediction for this particular VAWT scale. Within the low λ range, there is a distinct negative trough, with drag-dominated performance consistent to experimental results. Minimum C_p is computed to be -0.04 at $\lambda = 2$ and positive C_p is predicted to be attained at λ 's higher than 2.5. Maximum C_p is 0.33 at $\lambda^* = 4.5$ and a shift in the CFD-predicted C_p curve to higher λ 's is observed relative to the experimental C_p profile. The helix angle of the blade is changed at various angles ($0^\circ - 90^\circ$). There the stresses induced and the best angle for operation is determined.

REFERENCES

- [1] Hau.E. Wind Turbines, Fundamentals, Technologies, Application, Economics, 2nd ed.; Springer: Berlin, Germany, 2006.
- [2] Hull.D.G; Fundamentals of Airplane Flight Mechanics; Springer: Berlin, Germany, 2007.
- [3] AtifShahzad, TaimoorAsim, Rakesh Mishra, Achilleos Paris (2013), 'Performance of a Vertical Axis Wind Turbine under Accelerating and Decelerating Flows'.
- [4] Gorban.A.N, Gorlov.A.M, Silantyev.V.M; Limits of the turbine efficiency for free fluid flow. J. Energy Resour. Technol. Trans. ASME 2001, 123, 311–317.
- [5] Gorlov.A.M; 1995. Unidirectional helical reaction turbine operable under reversible fluid flow for power systems, US Patent 5,451,137, Sept. 19, 1995.
- [6] Holdsworth.B; Green Light for Unique NOVA Offshore Wind Turbine, 2009. Available online: <http://www.reinforcedplastics.com> (accessed on 8 May 2012).
- [7] D.Dellinger, "Wind – average wind speed", 2008, <http://www.ncdc.noaa.gov/oa/climate/online/ccd/avgwind.html>.
- [8] Burton.T; Wind Energy Handbook; John Wiley & Sons Ltd.: Chichester, UK, 2011.
- [9] I.Abbott and A.VonDoenhoff, Theory of Wing Sections Including a Summary of Airfoil Data, Dover, New York, NY, USA, 1959.
- [10] D'Ambrosio.M and Medaglia.M; 2010. Vertical Axis Wind Turbines: History, Technology and Application, Master thesis in Energy Engineering, May 2010.
- [11] HuiminWanga, JianliangWanga, JiYaoa, WeibinYuanb, Liang Caoa (2012); 'Analysis on the aerodynamic performance of vertical axis wind turbine subjected to the change of wind velocity'. Science Direct.