

Performance Analysis of TEG Based Solar PV System and Implementation of Hill Climbing MPPT Algorithm for Efficient Solar Water Pumping System

Sasirekha B¹, Baskaran K²P.G. Student, Department of Electrical Engineering, Government College of Technology, Coimbatore,
Tamilnadu, India¹Associate Professor, Department of Electrical Engineering, Government College of Technology, Coimbatore,
Tamilnadu, India²

ABSTRACT: This paper proposes the new Thermoelectric Generator based solar photovoltaic system for water pumping application. Thermoelectric power generation has emerged as a promising alternative green technology for the power generation from waste heat. Thermoelectric device generates voltage and electrical power from waste heat to electronic load by means of the temperature difference across solar panel and the atmosphere. To achieve maximum power input to the motor-pump setup, Hill climbing Algorithm is used. It starts with measuring the present values of the PV array voltage and current. Therefore, the generated power can be calculated and compared to its value calculated in the previous iteration. According to the result of comparison; the sign of a 'slope' is either complemented or remains unchanged and the PWM output duty cycle is changed accordingly. The power generated from the photovoltaic array is delivered to the load through a DC/DC converter to control the output voltage of the solar panel and achieve a maximum energy extraction. This paper also presents the details of system design and analyses of its dynamic behavior during varying environmental conditions are verified using MATLAB simulation.

KEYWORDS: Thermoelectric Generator, Hill climbing Algorithm, maximum energy extraction.

I. INTRODUCTION

Solar power system finds extensive application in remote areas where access to the grid supply is impractical. From livestock watering to remote home or village water supply needs are met from the solar based water pumps. Most of the PV water pumping systems are connected directly to the solar arrays and use DC motor driven pumps [1]. This system is easy to operate but is inefficient and requires frequent maintenance. Solar pump operated with AC drive uses an inverter with ac motor. Induction motor offer better choice in terms of size, ruggedness, efficiency and maintainability. The DC power from solar array is boosted and fed to an inverter which gives ac. Output of the inverter drives the motor coupled to a water pump. Photovoltaic power system usually requires maximum power point tracking (MPPT) controller, which is an electronic system that operates the Photovoltaic (PV) modules in a manner that allows the modules to produce all the power they are capable of. There are different types of MPPT algorithms like Fractional Order Extremum seeking, Fractional open circuit voltage method, incremental conductance method etc which can be grouped as traditional techniques.

Fractional open circuit voltage method finds the linear relationship between V_{mpp} and V_{oc} under varying irradiance and temperature levels. But V_{mpp} can be computed with measured V_{oc} by momentarily shutting down the power converter. This may lead to loss of power. Another MPPT method called incremental conductance uses two voltage and current sensors to sense the output voltage and current of PV array. This method used to calculate instantaneous conductance

International Journal of Innovative Research in Science, Engineering and Technology

(An ISO 3297: 2007 Certified Organization)

Vol. 5, Issue 5, May 2016

equals to the conductance of solar then MPP is reached. Cost and complexity of this method goes on increasing. Major disadvantage of this method is that it produces oscillations and performs erratically under rapidly changing atmosphere.

II. HILL CLIMBING MPPT ALGORITHM

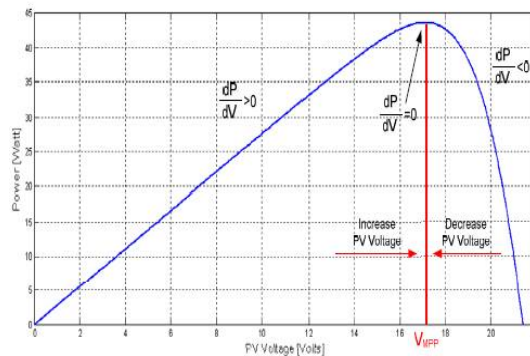

Figure.1 P-V curve of solar module

Figure-1 presents typical Power versus Voltage curve. Basic and simple operation of “Hill Climbing” algorithm is shown on this one. Red line represents that point where slope is zero and PV maximum power is extracted. When slope’s sign is positive a PV voltage increasing is essential in order to achieve operation in MPP. Similarly, a decreasing in PV voltage must be done in the case of a negative slope’s sign. Classic “Hill Climbing” algorithm can be operated both with a fixed and a variable voltage step change. During operation with a fixed voltage step size, there is no need to control the way that step is changed. Otherwise, in operation with a variable voltage step size it is necessary to find a way for controlling it flexibly.

New MPPT method that is presented in this paper, is actually a modification of classic “Hill Climbing” one. According to this, any P – V slope’s sign control and dynamic step size selection are avoided. The only thing that needs to be done is to calculate cube of P – V characteristic curve slope and add this to previous value of PV voltage. As shown on figure 3 (where x – axis represents slope and y – axis desirable voltage change) this modified algorithm is based on a hyperbola relation between slope and voltage step change. This kind of relation allows selection of bigger voltage step changes when slope is big, while step size is smaller as slope tends to be zero. When slope becomes zero there is no voltage change. In each calculation step cube of P – V curve’s slope is calculated and result is added in previous PV voltage value V_K . Through this procedure not only the desirable voltage changing direction, but also the appropriate voltage step change V_{ref} are resulted. Thus, no control operation is essential and the whole system is forced to operate under new voltage V_{K+1} . Following Figure-2 shows the flowchart of hill climbing algorithm.

International Journal of Innovative Research in Science, Engineering and Technology

(An ISO 3297: 2007 Certified Organization)

Vol. 5, Issue 5, May 2016

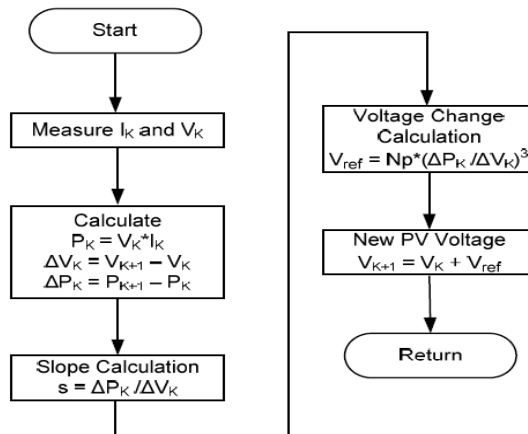

Figure.2 the flowchart of hill climbing algorithm

III THERMOELECTRIC GENERATOR

The direct conversion of solar heat to electrical energy can be achieved by means of thermoelectric generators (TEGs). TEGs work on the Seebeck effect. [2] Summarizes the different types of design according to the heat flow through the device and the layout of TCs. In lateral/lateral type the heat flow is lateral and the TCs layout is also lateral. In vertical/lateral type the heat flow is vertical and the TCs layout is lateral. In vertical/vertical type the heat flow is vertical and the TCs layout is also vertical. Thermal contact to heat source and sink is improved with a vertical design. This is because of the increased contact surface area. This increases the temperature difference between the hot and cold side. Since the output voltage is proportional to the temperature difference, voltage output increases and is considered for the experimental analysis.

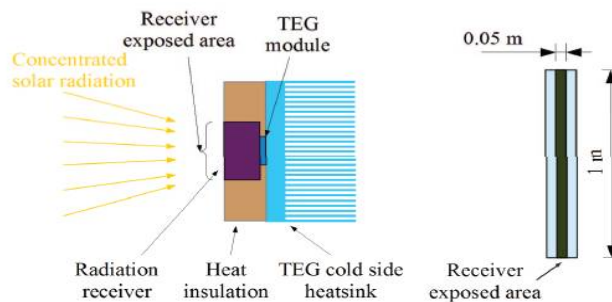

Figure.3 thermoelectric circuit

Figure-3 shows Thermoelectric generating circuit (TEG) that convert temperature differences into usable electricity. TEGs are made from thermoelectric modules which are solid-state integrated circuits that employ three established thermoelectric effects known as the Peltier, Seebeck and Thomson effects. TEGs require heat as an energy source and can generate power as long as there is a heat source such as gas or oil flame, stove, camp fire, industrial machinery, and furnace. Solar modules which convert light energy into usable electricity need direct sunlight to generate maximum rated power. Usually solar tracking systems are used to receive direct sun light to increase the efficiency of the modules. This type of setup increases the cost of the photovoltaic systems.

The use of TEGs based on thermoelectric effects (or Seebeck, Peltier, Thomson effect) is made possible by direct conversion of temperature differences to electrical power. The Seebeck effect occurs when a temperature difference exists between two dissimilar electrical conductors or semiconductors, producing a voltage across two materials.

International Journal of Innovative Research in Science, Engineering and Technology

(An ISO 3297: 2007 Certified Organization)

Vol. 5, Issue 5, May 2016

Thermal gradients in the environment are directly converted to electrical energy through the Seebeck (thermoelectric) effect. Temperature changes between opposite segments of a conducting material result in heat flow and consequently charge flow since mobile, high-energy carriers diffuse from high to low concentration regions. Thermopiles consisting of n- and p-type materials electrically joined at the high-temperature junction are therefore constructed, allowing heat flow to carry the dominant charge carriers of each material to the low temperature end, establishing a voltage difference across the base electrodes in the process.

The generated voltage and power is relative to the temperature differential and the Seebeck coefficient of the thermoelectric materials. Big thermal gradients are essential to produce practical voltage and power levels. However, temperature differences greater than 10°C are rare in a micro-system, so consequently such systems generate low voltage and power levels. Moreover, naturally occurring temperature variations can also provide a means by which energy can be scavenged from the environment with high temperature. Stordeur and Stark have demonstrated a thermoelectric micro-device which is capable of converting 15 $\mu\text{W}/\text{cm}^3$ from 10 °C temperature gradients. While this is promising and, with the improvement of thermoelectric generators, could eventually result in more than 15 $\mu\text{W}/\text{cm}^3$, situations in which there is a static 10 °C temperature difference within 1 cm^3 are very rare. This, however, assumes no losses in the conversion of power to electricity.

IV SOLAR WATER PUMPING SYSTEM

The drastic reduction in the cost of power electronic devices and annihilation of fossil fuels in near future invite to use the solar photovoltaic (SPV) generated electrical energy for various applications as far as possible. The water pumping, a standalone application of the SPV array generated electricity is receiving wide attention now a days for irrigation in the fields, household applications and industrial use.

The merits of both BLDC motor and zeta converter can contribute to develop a SPV array fed water pumping system possessing a potential of operating satisfactorily under dynamically changing atmospheric conditions. The BLDC motor has high reliability, high efficiency, high torque/inertia ratio, improved cooling, low radio frequency interference and noise and requires practically no maintenance [5-6]. On the other hand, a zeta converter exhibits following advantages over the conventional buck, boost, buck-boost converters and Cuk converter when employed in SPV based applications.

Belonging to a family of buck-boost converters, the zeta converter may be operated either to increase or to decrease the output voltage. This property offers a boundless region for maximum power point tracking (MPPT) of a SPV array. The MPPT can be performed with simple buck and boost converter if MPP occurs within prescribed limits.

This property also facilitates the soft starting of BLDC motor unlike a boost converter which habitually steps up the voltage level at its output, not ensuring soft starting. Unlike a classical buck-boost converter, the zeta converter has a continuous output current. The output inductor makes the current continuous and ripples free. Although consisting of same number of components as a Cuk converter, the zeta converter operates as non-inverting buck-boost converter unlike an inverting buck-boost and Cuk converter. This property obviates a requirement of associated circuits for negative voltage sensing hence reduces the complexity and probability of slow down the system response. These merits of the zeta converter are favorable for proposed SPV array fed water pumping system. An fractional order extremum seeking approach (FOESA) MPPT algorithm is used to operate the zeta converter such that SPV array always operates at its MPP.

Two phase currents are sensed along with Hall signals feedback for control of BLDC motor, resulting in an increased cost. The additional control scheme causes increased cost and complexity, which is required to control the speed of BLDC motor. Moreover, usually a voltage source inverter (VSI) is operated with high frequency PWM pulses, resulting in an increased switching loss and hence the reduced efficiency. Figure-4 shows the hardware implementation of BLDC based solar water pump.

International Journal of Innovative Research in Science, Engineering and Technology

(An ISO 3297: 2007 Certified Organization)

Vol. 5, Issue 5, May 2016



Figure.4 hardware implementation of BLDC based solar water pump.

VSIMULATIONS AND RESULTS

The simulation is done using MATLAB and the results are presented here.

A. Simulation Zeta Converter- Inverter System fed Induction Motor for P V Pumping.

The Simulink model of Zeta converter-inverter system for PV pumping fed induction motor is shown in Fig . The 12V DC input is boosted and converted to 230V AC using three-phase inverter. The switches of inverter operate at a high frequency of 20 kHz. This 230V, 20 kHz AC is converted to 400V DC. Another converter stage is required to reduce the frequency. As the 3phase inverter switches operates at 50 Hz, it converts 400V DC to 500V, 50 Hz AC which can be fed to the induction motor. The output voltage waveform of zeta converter- inverter system for PV pumping fed induction motor is shown in Figure.5

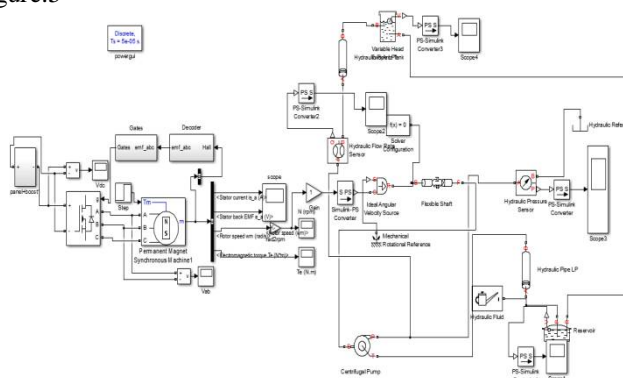

Figure.5 Simulation of BLDC based solar pumping system

BLDC water pumps in general use one-third to one-half the energy of conventional AC (alternating current) pumps. BLDC pumps are classed as either displacement or centrifugal, and can be either submersible or surface types. Displacement pumps use diaphragms, vanes or pistons to seal water in a chamber and force it through a discharge outlet. Centrifugal pumps use a spinning impeller that adds energy to the water and pushes it into the system, similar to a water wheel. Submersible pumps, placed down a well or sump, are highly reliable because they are not exposed to freezing temperatures, do not need special protection from the elements, and do not require priming. Surface pumps, located at or near the water surface, are used primarily for moving water through a pipeline. Some surface pumps can develop high heads and are suitable for moving water long distances or to high elevations. The simulation waveform has been shown in figure-6.

International Journal of Innovative Research in Science, Engineering and Technology

(An ISO 3297: 2007 Certified Organization)

Vol. 5, Issue 5, May 2016

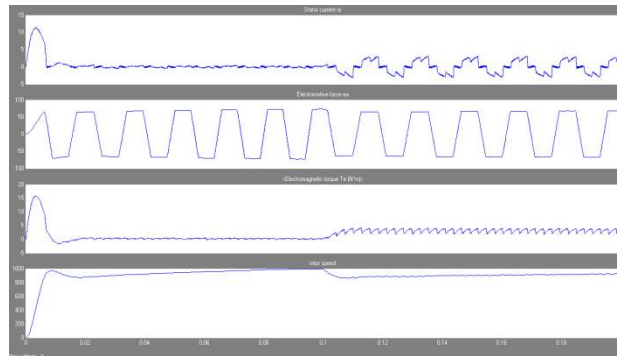

Figure.6 Output waveform from BLDC Motor

This purpose built motor is the result of years of research and development by the engineering staff at Mono. Specifically designed for use in solar pumps, this high torque motor is extremely efficient, the motor is fully sealed and oil filled. This design allows for an extremely long life in the hardest of applications. There are no brushes to wear out, therefore no maintenance

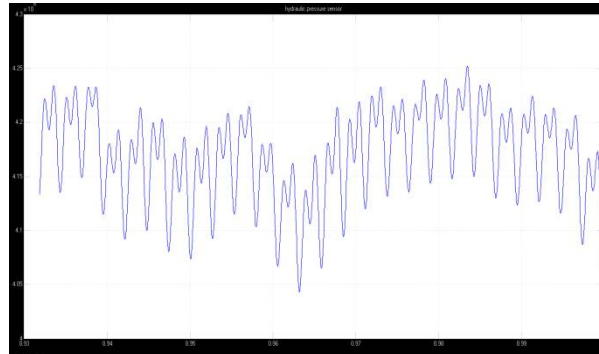

Fig.7 Output waveform from hydraulic sensor

The above figure 7 shows the output waveform of hydraulic sensor, A pressure sensor measures pressure, typically of gases or liquids. Pressure is an expression of the force required to stop a fluid from expanding, and is usually stated in terms of force per unit area.

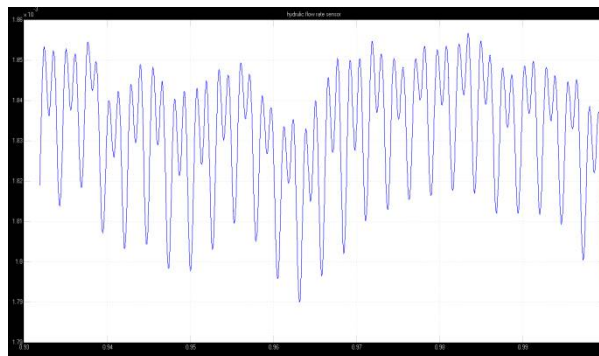

Fig.8 Output waveform from hydraulic flow rate sensor

International Journal of Innovative Research in Science, Engineering and Technology

(An ISO 3297: 2007 Certified Organization)

Vol. 5, Issue 5, May 2016

The above figure shows the output waveform of hydraulic flow rate sensor, A flow sensor is a device for sensing the rate of fluid flow. Typically a flow sensor is the sensing element used in a flow meter, or flow logger, to record the flow of fluids. As is true for all sensors, absolute accuracy of a measurement requires a functionality for calibration.

VI. CONCLUSION

This paper has evaluated the analysis of Photovoltaic cells and BLDC based water pumping system. Analysis, modelling and design of zeta converter with LC filter are also presented. The selection criteria of electric drive for photovoltaic pumping are elaborated. The 3 phase inverter in 180 and 120 mode operations is simulated. It is observed that the 180 mode is superior to 120 mode of operation. Common mode voltage is measured and it is observed that the common mode noise is reduced by using LC filter. The closed loop system is successfully modelled and simulated using the blocks of Simulink. The simulation results are in line with the predictions.

REFERENCES

- [1] Kala Meah, Steven Fletcher and SadrulUla, "Solar Photovoltaic Water Pumping for Remote Locations," *Renewable and Sustainable EnergyReviews*, vol. 12, no. 2, pp. 472-487, February 2008.
- [2] C. Gopal, M. Mohanraj, P. Chandramohan and P. Chandrasekar, "Renewable Energy Source Water Pumping Systems—A Literature Review," *Renewable and Sustainable Energy Reviews*, vol. 25, pp. 351- 370, September 2013.
- [3] J. V. Mapurunga Caracas, G. De CarvalhoFarias, L. F. Moreira Teixeira and L. A. de Souza Ribeiro, "Implementation of a High-Efficiency, High-Lifetime, and Low-Cost Converter for an Autonomous Photovoltaic Water Pumping System," *IEEE Transactions on IndustryApplications*, vol. 50, no. 1, pp. 631-641, Jan.-Feb. 2014.
- [4] Mehmet Akbaba, "Matching Induction Motors to PVG for Maximum Power Transfer," *Desalination*, vol. 209, no. 1-3, pp. 31-38, 2007.
- [5] A. Boutellig, Y. Bakelli, I. HadjMahammed and A. Hadj Arab, "Performances Study of Different PV Powered DC Pump Configurations for an Optimum Energy Rating at Different Heads Under the Outdoor Conditions of a Desert Area," *Energy*, vol. 39, no. 1, pp. 33- 39, March 2012.
- [6] N. Chandrasekaran, G. Ganeshprabu and K. Thyagarajah, "Comparative Study of Photovoltaic Pumping System Using a DC Motor and PMDC Motor," *International Conference on Advances in Engineering, Scienceand Management (ICAESM)*, pp. 129-132, 30-31 March 2012.
- [7] AbdelmalekMokeddem, AbdelhamidMidoun, D. Kadri, Said Hiadi and Ifikhar A. Raja, "Performance of a Directly-Coupled PV Water Pumping System," *Energy Conversion and Management*, vol. 52, no. 10, pp.3089-3095, September 2011.
- [8] S. Henneberger, S. Van Haute, K. Hameyer and R. Belmans, "Submersible Installed Permanent Magnet Synchronous Motor for a Photovoltaic Pump System," *IEEE International Electric Machines andDrives Conference Record*, pp. WB2/10.1-WB2/10.3, 18-21 May 1997.
- [9] R. Chennai, L. Zarour, A. Bouzid and T. Kerbach, "Comparative Study of Photovoltaic Pumping Systems Using a Permanent Magnet Synchronous Motor (PMSM) and an Asynchronous Motor (ASM)," *Rev. Energy Ren.* Vol. 9, pp. 17-28, 2006.
- [10] M. Dubey, S. Sharma and R. Saxena, "Solar PV Stand-alone Water Pumping System Employing PMSM Drive," *IEEE Students' Conferenceon Electrical, Electronics and Computer Science*, pp. 1-6, 2014.
- [11] M. Nabil, S. M. Allam and E. M. Rashad, "Modeling and Design Considerations of a Photovoltaic Energy Source Feeding a Synchronous Reluctance Motor Suitable for Pumping Systems," *Ain ShamsEngineering Journal*, vol. 3, no. 4, pp. 375-382, December 2012.
- [12] M. Nabil, S. M. Allam and E. M. Rashad, "Performance Improvement of a Photovoltaic Pumping System Using a Synchronous Reluctance Motor," *Electric power Components and systems*, vol. 41, no. 4, pp. 447-464, Jan. 2013.
- [13] A. Domijan and T.A. Buchh, "Photovoltaic Array Driven Adjustable Speed Heat Pump and Power System Scheme for a Lunar Based Habitat," *IEEE Trans. Energy Convers.*, vol.13, no.4, pp. 366-372, 1998.
- [14] S. Belliwali, A. Chakravarti and A. B. Raju, "Mathematical Modelling and Simulation of Directly Coupled PV Water Pumping System Employing Switched Reluctance Motor," *IEEE PES Innovative SmartGrid Technologies - India (ISGT India)*, pp. 386-390, 1-3 Dec. 2011.
- [15] Hamid M. B. Metwally and Wagdy R. Anis, "Performance Analysis of PV Pumping system Using Switched Reluctance Motor Drives," *EnergyConversion and Management*, vol. 38, no. 1, pp. 1-11, Jan. 1997.
- [16] S. A. K. H. MozaffariNiapour, S. Danyali, M.B.B. Sharifian and M.R.Feyzi, "Brushless DC Motor Drives Supplied by PV Power System Based on Z-Source Inverter and FL-IC MPPT Controller," *EnergyConversion and Management*, vol. 52, no. 8-9, pp. 3043-3059, 2011.
- [17] A. Terki, A. Moussi, A. Betka and N. Terki, "An Improved Efficiency of Fuzzy Logic Control of PMBLDC for PV Pumping System," *AppliedMathematical Modelling*, vol. 36, no. 3, pp. 934-944, March 2012.
- [18] M. Ouada, M.S. Meridjet and N. Talbi, "Optimization Photovoltaic Pumping System Based BLDC Using Fuzzy Logic MPPT Control," *Int.Renewable and Sustainable Energy Conf.*, pp. 27-31, 7-9 March 2013.
- [19] Zhou Xuesong, Song Daichun, Ma Youjie and Cheng Deshu, "The Simulation and Design for MPPT of PV System Based on Incremental Conductance Method," *WASE International Conference on InformationEngineering (ICIE)*, vol. 2, pp. 314-317, 14-15 Aug. 2010.
- [20] M. Krstic, Performance improvement and limitation in extremum seeking control. *Systems and Control Letters*, vol. 39, pp. 313-326, 2000.
- [21] K. J. Astrom, and B. Wittenmark, Adaptive Control (2nd ed). Reading, MA: Addison-Wesley, 1995.
- [22] D. Carnevale, A. Astolfi, C. Centioli, S. Podda, V. Vitale, and L.Zaccarian, A new extremum seeking technique and its application to maximize RF heating on FTU. *Fusion Engineering and Design*, vol. 84, pp. 554-558, 2009.

International Journal of Innovative Research in Science, Engineering and Technology

(An ISO 3297: 2007 Certified Organization)

Vol. 5, Issue 5, May 2016

- [23] S. Ladaci, and A. Charef, MIT adaptive rule with fractional Integration, in Proc. CESA'2003 IMACS Multiconference Computational Engineering in Systems Applications, Lille-France, July 9-11, 2003, pp.5384-5392, Oct. 2014.
- [24] TeyKok Soon and S. Mekhilef, "A Fast-Converging MPPT Technique for Photovoltaic System Under Fast-Varying Solar Irradiation and Load Resistance," *IEEE Trans. Ind. Informat.*, vol.11, no.1, pp.176-186, 2015.
- [25] M. H. Taghvaei, M. A. M. Radzi, S. M. Moosavain, Hashim Hizam and M. HamiruceMarhaban, "A Current and Future Study on Non-isolated DC-DC Converters for Photovoltaic Applications," *Renewable and Sustainable Energy Reviews*, vol. 17, pp. 216-227, Jan. 2013.
- [26] Ned Mohan, Tore M. Undeland and William P. Robbins, *Power Electronics: Converters, Applications and Design*, 3rd ed. New Delhi, India: Jhon Wiley & sons Inc., 2009.
- [27] Dylan D.C. Lu and Quang Ngoc Nguyen, "A Photovoltaic Panel Emulator Using A Buck-Boost DC/DC Converter and A Low Cost Micro-Controller," *Solar Energy*, vol. 86, no. 5, pp. 1477-1484, 2012.
- [28] R. Akkaya, A.A. Kulaksız and Ö. Aydoğdu, "DSP Implementation of a PV System with GA-MLP-NN Based MPPT Controller Supplying BLDC Motor Drive," *Energy Conversion and Management*, vol. 48, no. 1, pp. 210-218, January 2007.