

International Journal of Innovative Research in Science, Engineering and Technology

(An ISO 3297: 2007 Certified Organization)

Vol. 5, Issue 5, May 2016

Microcontroller Based Brain Entrainment

Gaurav Rohilla¹, Sakshi Sethi²

Student, B.Tech, Department of Biomedical Engineering, Amity University, Gurgaon, Haryana, India¹

Assistant Professor, Department of Biomedical Engineering, Amity University, Gurgaon, Haryana, India²

ABSTRACT: Stress and strain affects each and every one of us in one form or the other. Cortisol is a steroid hormone secreted by adrenal gland in response to stress and low blood glucose. As per clinical advice, hypercortisone as an injection is used to treat this condition. Alternate to this method, doctors and physicians suggest use of Brainwave entrainment devices. In Brainwave entrainment, audios and light are used to maintain focus in order to reap the benefits of meditation. In this project we are using AT89C2051 microcontroller for the rhythmic blinking of 8 LED's (light emitting diodes). Timer 555 IC is used as a timer in the circuit. A set of earphones are also used so for the purpose of generating Binaural beats for the relaxation of brain. Also, a 9V battery is used to power the circuit.

KEYWORDS: Microcontroller AT89C2051, Brainwave entrainment, Binaural Beats and LED's.

I. INTRODUCTION

The brain which is composed of more than 100 billion nerve cells is a sophisticated biochemical factory. For many years, neurologists, psychotherapists, researchers, and other healthcare professionals have studied the human brain. Brainwave entrainment refers to the brain's electrical response to rhythmic sensory stimulation, such as pulses of sound or light. (1) Entrainment is the process where two interacting oscillating systems, which have different periods when they function independently, but our brain assumes the period in between them. The two oscillators may fall into synchrony. (2) The developed hardware for light brainwave stimulator basically consists of eyeglasses with 4 LED's on each glass. A pair of earphones, connected with Timer 555 IC for continuous binaural beats. The most important objective of developing such a device is that it is low cost, user friendly and portable, easy to use, it is not bulky and can be used even at bedside. As we are giving the 9V changeable batteries, the risk of shock is not there and user can use the product for 16 hours continuously (3 nights). There are two different circuits having the same input source of battery. The first circuit is for the light entrainment procedure whereas the second circuit connected with a pair of earphones is for binaural beats. Figure 1 depicts the EEG reading before and after the entrainment process.

II. BACKGROUND STUDY

The first known clinical application of BWE (brainwave entrainment) was introduced from the French psychologist, Pierre Janet, in the late 1800s. (3) After the initial demonstration of Berger in 1934 on electrical activity recorded from the human brain, Adrian and Mathews showed that the Berger rhythm (alpha) could be further amplified by photo stimulation at the same frequency. (4) In 1839 German scientist Heinrich Wilhelm Dove (5) discovered that by listening of two tones of different frequencies, each on one ear, one actually, besides the two tones, hears a third one, completely different tone called binocular beat.

International Journal of Innovative Research in Science, Engineering and Technology

(An ISO 3297: 2007 Certified Organization)

Vol. 5, Issue 5, May 2016

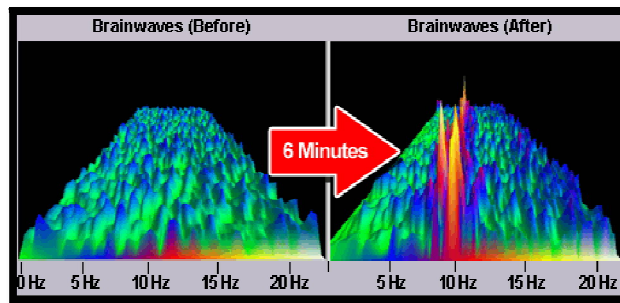

Figure 1: Electrocardiogram readings after 6 minutes of BWE (6)

It helps to achieve brainwave frequencies that are characteristic for certain state of consciousness (7):

- Delta waves (They are generated in deepest meditations): 0.5 to 3 Hz
- Theta waves (Learning and memory): 3 to 8 Hz
- Alpha waves (Calmness and resting state for brain): 8 to 12 Hz
- Beta waves (Decisions making and problem solving): 12 to 38 Hz
- Gamma waves (spare brain noise): 38 to 42Hz.

III. COMPONENTS USED

3.1 MICROCONTROLLER

A microcontroller AT89C2051 is used which is low voltage, high performance 8 bit microcontroller. It has 2K of reprogrammable flash memory, 15 I/O lines, 128 bytes of RAM and clock circuitry. It is fully compatible with MCS-51 architecture and can be programmed using MCS-51 instruction set. (8) Port 1 has 8 bit bi-directional I/O pins. Port 3 have 7 bi-directional I/O pins. In this circuit P1-0 – P1-7 is connected to the LED driver IC ULN 2003. P3-5 is taking input pulses from IC 555 circuit. Pin 10 and 20 are GND and VCC respectively. GND stands for ground while VCC is supply voltage. (Figure 2)

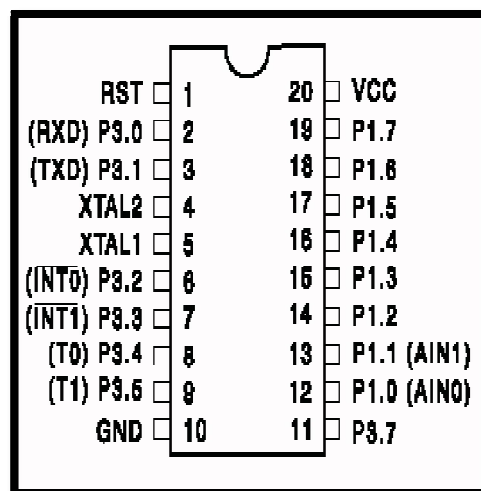

Figure 2: ATMEL AT89C2051 (9)

3.2 TIMER 555

555 astable multivibrator provides the variable square wave pulses to the microcontroller circuit. An Astable Multivibrator is an oscillator circuit that continuously produces rectangular wave without the aid of external triggering. Here Pin 1 is grounded to (-) ve supply and pin 4 (reset) and Vcc pin 8 connected to the (+) ve supply of the battery.

International Journal of Innovative Research in Science, Engineering and Technology

(An ISO 3297: 2007 Certified Organization)

Vol. 5, Issue 5, May 2016

Basically 8th and 1st Pin of the astable multivibrator is used for power, Vcc and GND respectively. The 4th pin is RESET pin which is active low and is connected to Vcc to avoid accidental resets. Threshold (pin 6) and trigger (pin 2) are connected together and providing a variable resistance connected to the discharge pin 7 to change the frequency pulses at output from pin 3 of 555 IC. Regenerative switching circuits such as astable Multi-vibrators are the most commonly used type of relaxation oscillator because not only are they simple, reliable and ease of construction they also produce a constant square wave output waveform. (10)

3.3 ULN 2003

ULN 2003A is a combination of 7 NPN Darlington transistors. Pin 13 of ULN is common for both right and left eye LED's section. The supply to LED is common (Vcc+). A Darlington transistor (also known as Darlington pair) achieves very high current amplification by connecting two bipolar transistors in direct DC coupling so the current amplified by the first transistor is amplified further by the second one. The resultant current gain is the product of those of the two component transistors (11):

$$\beta_{total} \approx \beta_1 \cdot \beta_2$$

3.4 CAPACITORS

Two types of capacitors are used in the circuit: **Ceramic** and **electrolytic capacitors**. Electrolytic capacitors consist of two small sheets of metal, shaped into a cylinder whereas ceramic capacitors have no polarity and are made up of layering conductor sheets which alternate with ceramic material. (12) Electrolytic capacitors have large capacity, which means that they can accumulate a large amount of energy than ceramic capacitors. There are 8 capacitors used in the circuit, among which 6 are electrolytic capacitors and 2 ceramic capacitors. First 2 capacitors are connected for input supply 470µF and 100µF respectively. Power to both the circuits is provided from the same input source.

3.6 SOFTWARE

The programming has been done with the help of Keil Microvision 3 IDE. It is very easy to understand. The software itself comes with a tutorial on how to program the microcontroller chip. This software basically converts the embedded 'C' program into a compatible file 'HEX'. You will also require a software known as 'Flash Magic' to burn the compatible file into the microcontroller. For more about this software you can log onto Keil website. (13)

IV. METHODOLOGY

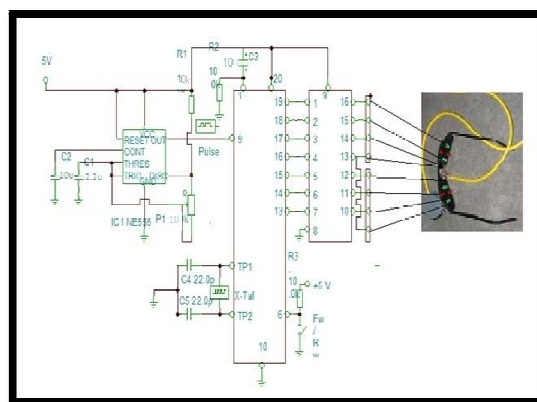

Figure 3: LED controlling circuit

With the input supply from a 9v battery, the LED circuit works on 5v of energy. (Figure 3) As soon as the circuit starts, timer 555 sends pulse to the microcontroller. With the variable resistance we can easily control the square wave generated. This square wave works as an input for the microcontroller. XTAL1 and XTAL2 are the input and output,

International Journal of Innovative Research in Science, Engineering and Technology

(An ISO 3297: 2007 Certified Organization)

Vol. 5, Issue 5, May 2016

respectively, of an inverting amplifier that can be configured for use as an on-chip oscillator. Either a quartz crystal or ceramic resonator may be used. After the processing in microcontroller, the signal is then sent to the ULN 2003 driver IC. This IC serves the purpose of amplification. Pin 13 of ULN is common for both right and left eye LED's sections. The program defines the blinking of LED's. There are 4 LEDs on each side. When the blinking starts, 2 LEDs on each side blinks. After a delay of .5 seconds these LEDs stops blinking and other two starts blinking.

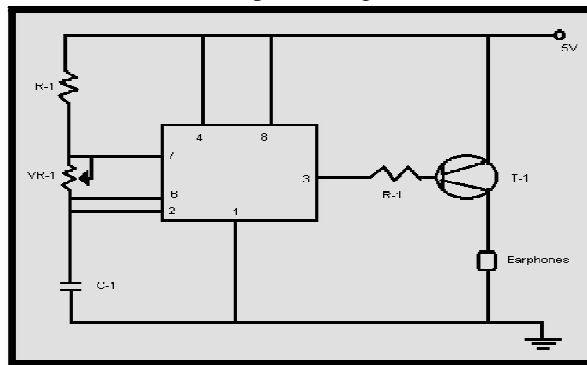

Figure 4: Circuit for Binaural Beats

This circuit is the for the purpose of sound. (Figure 4) It also runs on 5V of energy. Again astable multivibrator 555 is used. This time there's no need of a microcontroller. The pulse generated from the multivibrator are used to create the binaural beats. Generally two tones are used at different frequency in each ear and then the user hears a 3rd sound (binaural beat). This is due to cortical evoked response. Beats at a chosen frequency can increase brain activity in that specific frequency. With the help of variable resistance we can modulate the beats frequency.

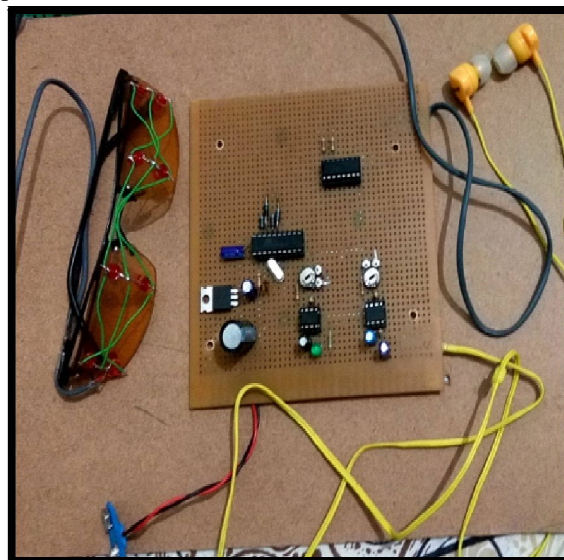

Figure 5: Hardware mode of Brainwave entrainment

V. CONCLUSION

The conclusion of this paper is that brainwave entrainment is emerging topic in the field of neurology and there is a lot more to research in this area. Furthermore, there are no devices in the market at such a cheap price that uses both sound and light as source for entrainment. Hence, this device is not only cheap but also user friendly in comparison to any

International Journal of Innovative Research in Science, Engineering and Technology

(An ISO 3297: 2007 Certified Organization)

Vol. 5, Issue 5, May 2016

other device present in the market. This device is also robust and it is also portable. As the circuit works on 5V of power, we can use a 9V battery to provide sufficient power to the circuit. But the drawback in this case is that battery drains very fast and it is always hectic for the user to keep on changing the battery. (Figure 5)

REFERENCES

1. Brain wave entrainment. Transparent corp. [Online] <https://www.transparentcorp.com/products/np/entrainment.php>.
2. Tianbao Zhuang, Hong Zhao, Zheng Tang. A Study of Brainwave Entrainment Based on EEG Brain Dynamics, Vol. 2, p. 81, 2009.
3. Francesco Casciaro, Vincenza Laterza, Sergio Conte, et al. Alpha-rhythm stimulation using brain entrainment enhances heart rate variability in subjects with reduced HRV. Vol. 3, 2013.
4. Alpha rhythm stimulation using brainwave entrainment. Casciaro, Francesco. s.l. : World Journal of Neuroscience, 2013, Vol. 3.
5. Binaural Blog. Discovery of Binaural Beats. [Online] 2016. <http://www.binauralblog.com/?p=62>.
6. To the next level. Volition Neuro Research Institute. [Online] 2010. <https://www.vth.biz/driver/nextlevel>.
7. Personal brain performance programmes. Brain works-train your mind. [Online] <http://www.brainworksneurotherapy.com/what-are-brainwaves>.
8. AT89C2051. ATMEL. [Online] 2008. <http://www.atmel.com/images/doc0368.pdf>.
9. Atmel AT89C2051 microcontroller. hw-server.com. [Online] 2014. <http://hw-server.com/atmel-at89c2051-programmer>.
10. Home / Waveform Generator / Astable Multivibrator. Electronics Tutorial. [Online] April 2016. <http://www.electronics-tutorials.ws/waveforms/astable.html>.
11. Darlingtons transistors. Electronics tutorials. [Online] April 4th, 2016. <http://www.electronics-tutorials.ws/transistor/darlington-transistor.html>.
12. Renee Miller. Difference between Electrolytic and Ceramic capacitors ? E How. [Online] http://www.ehow.com/info_7832763_difference-between-electrolytic-ceramic.html.
13. MicroVision IDE. ARMKEIL. [Online] 2015. <http://www2.keil.com/mdk5/uvision/>.