

Copyright Protection of Digital Images using FIS-BPNN Technique in Hybrid Transform Domain

Podili Brahma Srinu¹, B.Jagadeesh²P.G. Student, Department of ECE, GVP College of Engineering (A), Visakhapatnam, A.P, India¹Associate Professor, Department of ECE, GVP College of Engineering (A), Visakhapatnam, A.P, India²

ABSTRACT: Now a day's Internet spread over the world. This increases the availability of digital data, such as audio, images and videos to the outside world. These digital media can be easily manipulated, so the protection of digital data becomes difficult. Watermarking is the best solution for this problem. Digital watermarking is a technology being developed to make certain changes and ease data authentication, security and copyright protection of digital media. Present day, many image watermarking methods are available. But these are facing some drawbacks, i.e. trade-off between robustness and imperceptibility. To overcome this trade-off problem, artificial intelligence techniques such as Fuzzy Logic and Back Propagation Neural Networks are followed in the present work. In this paper, a robust and blind image watermarking is proposed using both Fuzzy Logic and Back Propagation Neural Networks in hybrid transform domain i.e. combination of DCT and DWT. The proposed system gives better robustness with some attacks like rotation, cropping, image contrast attack, and salt and pepper noise etc.

KEYWORDS: Discrete Cosine Transform, Discrete Wavelet Transform, Fuzzy Inference System, Back Propagation Neural Network, Peak Signal Noise Ratio, Normalized Cross Correlation.

I. INTRODUCTION

Internet, with its fast growth, becomes an exceptional distribution system for digital media because of inexpensiveness and immediate delivery. However, these digital data easy to manipulate so the threat of piracy and copyright attacks are high in digital data. Thus, it is of large importance to go for advanced technologies that guarantee to protect the content owner. The digital image watermarking method is fundamentally characterized into three necessary steps: embedding of watermark, apply different attacks and detection of the watermark from watermarked image. In the embedding algorithm, the digital watermark is embedded into the host image, then it produces the watermarked image. Next the watermarked image is transmitted into the channel or stored in somewhere. In general, it is transmitted to another person. In that scenario some persons try to make an alteration of the watermarked image, then it is known an attack. In detection algorithm, the attacked watermark is used for separation of the host image and watermark. [1].

Digital image watermarking can be characterized into three different categories visible, invisible and dual watermarks. These Visible watermarks are easily seen by the normal viewer. In invisible watermarks, the embedded watermark is invisible on the watermarked image. Digital Watermark is hidden inside the host image. Dual watermarks are the combination of both visible and invisible watermarks. Based on robustness watermarks are categorized into three different categories, i.e. Robust, fragile, and semi-fragile watermarks. Watermarking can be done mainly two ways, namely spatial domain and transform domain. In the spatial domain, watermarking can be done directly modifying the pixels of digital images. In frequency domain, image pixel values are converted from the spatial domain to the frequency domain by using some techniques those are DCT, DWT, SVD and DFT and operations are performed on these modified pixel values. In this paper, digital image watermarking technique is proposed using a hybrid transform technique, i.e. combination of both DCT and DWT.

International Journal of Innovative Research in Science, Engineering and Technology

(An ISO 3297: 2007 Certified Organization)

Vol. 5, Issue 10, October 2016

II. RELATED WORK

Throughout the years, many scholars have proposed different algorithms for image watermarking some of them are explained as Charu Agrawal et.al [1] proposed an algorithm based on Fuzzy Neural system using Discrete Cosine Transform (DCT), it uses 27 inference rules which are created by using HVS parameters to embedding the watermark and in extraction use semi- blind method i.e. it uses some of the original image information or watermark information. Mehul S Raval et.al [2] proposed an algorithm using Haar wavelet for embedding watermark in transform domain and Fuzzy-Neural system is used for extraction of the watermark along with super resolution. Nallagarla et.al [4] Proposed an image watermarking technique using Back Propagation Neural Network (BPNN) and Fuzzy Inference System (FIS) separately in transform domain by using DWT, and compared both the watermarking methods using BPNN and FIS for robustness against different image processing attacks and gives which is better watermarking method. Qiao Baoming et.al [6] proposed a digital image watermarking technique in transform domain, i.e. DWT and using Back Propagation Neural Network (BPNN). The proposed method verified for different image processing attacks and give performance metric values. Hinal M. Mudia et.al [8] proposed an image watermarking algorithm based on fuzzy logic. These fuzzy logic based digital image encryption for secret data transfer using (2, 2) covert sharing scheme. U.S.N.Raju et.al [10] proposed an image watermarking technique in transform domain which combines DCT and DWT to construct the watermarked image. The proposed watermarking method allows us to obtain visible as well as the invisible watermarked images by varying the value of the scaling factor. The imperceptibility is measured using numerical parameters such as PSNR and MSE for different values of the scaling factor.

III. PRELIMINARIES

A. DISCRETE WAVELET TRANSFORM (DWT)

Both time and frequency domain information of digital images are given by using the DWT. This wavelet transform is used for the analysis of small signals. Wavelets are created by translations and dilations of a preset function known as mother wavelet.

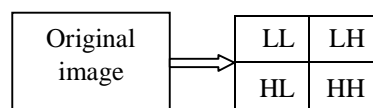

Fig 1: DWT Decomposition

The original host image can be decomposed into three spatial directions by using these DWT namely: horizontal, vertical and diagonal details. In the lower sub band (LL), the magnitude of DWT coefficients are higher value and remaining sub bands having lower values those are HH, LH and HL, at each level of decomposition of an image. Edge and texture patterns are easily recognized in high resolution sub bands of an image. The Wavelet transform is the better transform model in the usage of HVS, compared to other transforms like DFT, DCT and FFT. Embedding of higher energy watermarks into the host image also allows by using this transform, where HVS is less sensitive to the human eye. Embedding of watermark in these less sensitive areas of the host image allow us to improve robustness of the watermark with all processing attacks without damaging the image transparency [4]. In the proposed work, 1-level DWT is applied to the host image by using Haar wavelet because it is the simplest wavelet when compared to other wavelets.

B. DISCRETE COSINE TRANSFORM (DCT)

By applying DCT to the digital image, these converts the image into a sum of sinusoidal coefficients. This transform converts an image signal from the time domain to frequency domain representation. Watermarking can be done by using DCT gives less computational complexity when compared to other transforms like FFT, DWT etc. Embedding of watermark image into lower frequency areas of an image will damage the image fidelity, this arise imperceptibility

International Journal of Innovative Research in Science, Engineering and Technology

(An ISO 3297: 2007 Certified Organization)

Vol. 5, Issue 10, October 2016

problems, i.e. Alter the original image data because these areas take place most of the image information. Embedding of watermark into higher frequency areas of the image is not sustaining to all attacks such as compression, cropping etc., i.e. facing robustness problems. So, in this paper the proposed algorithm used middle frequency areas of the image for embedding watermark this increases the robustness of the watermarking with all processing attacks [5,7]. Two dimensional DCT of a given image A of size M*N is defined as

$$B_{st} = \alpha s a t \sum_{m=0}^{M-1} \sum_{n=0}^{N-1} A_{mn} \left(\frac{\cos(2\pi m+1)s}{2M} \right) \left(\frac{\cos(2\pi n+1)t}{2N} \right) \text{ For, } 0 \leq s \leq M-1, 0 \leq t \leq N-1 \quad (1)$$

$$\alpha p = \begin{cases} \frac{1}{\sqrt{M}}, & s = 0 \\ \frac{2}{\sqrt{M}}, & 1 \leq s \leq M-1 \end{cases}$$

$$\alpha q = \begin{cases} \frac{1}{\sqrt{N}}, & t = 0 \\ \frac{2}{\sqrt{N}}, & 1 \leq t \leq N-1 \end{cases}$$

s and t varies from 0 to M-1, 0 to N-1 respectively, where M*N is the size of the original image. The DCT is invertible transform and its inverse is given by

$$A_{mn} = \alpha s a t \sum_{s=0}^{M-1} \sum_{t=0}^{N-1} B_{st} \left(\frac{\cos(2\pi n+1)s}{2M} \right) \left(\frac{\cos(2\pi m+1)t}{2N} \right)$$

C. HUMAN VISUAL SYSTEM

In order to embed watermark into the images with maximum extent, HVS model is used. HVS model is less sensitive to noise; this advantage was used for an image watermarking technique. In some areas of the image can make small changes that are not recognized by the human eye by selecting such areas and embedded the watermark in these areas to improve the transparency of the watermarked image. These areas of the digital image are selected by using HVS parameter. For the calculation of these HVS parameters is done by using transform coefficients of the image. These HVS parameters are given as inputs to Fuzzy logic and Neural Network. These HVS parameters are explained below as [7]

Luminance Sensitivity:

Luminance means brightness. Transform coefficients are used for calculating these HVS parameters. The DC coefficient of the each DCT block of the host image is used for finding "luminance sensitivity". Eq. 2 gives luminance sensitivity values:

$$L_s = X_{dc,i} / X_{dc,m} \quad (2)$$

Where $X_{dc,i}$ denotes the DC coefficient of the i^{th} block of the host image and $X_{dc,m}$ is the mean value of the DC coefficients of all the blocks of the host image put together.

Texture Sensitivity:

Texture means the spatial arrangement of color. The total area in the host image can be characterized into three areas, namely: smooth area, texture area, and edges. Texture areas of the image are easier to survive the noise because noise cannot be noticed in these texture areas because noise also mixed with the texture areas. This texture sensitivity can be calculated by using

$$T_k = \sum_{s,t=1}^M \text{cond} \left(\frac{v_k(s,t)}{Q(s,t)} \right) \quad (3)$$

where (s,t) is the location of the k^{th} block of an image. Q is the JPEG quantization table. Cond (B) gives rounded value to 1 if $B \neq 0$ else value is 0.

Edge Sensitivity:

The Edges of the images are less sensitive to noise. Maximum edge information stored in high frequency areas. This routine is implemented in Matlab by using

$$T = \text{graythresh} (x) \quad (4)$$

International Journal of Innovative Research in Science, Engineering and Technology

(An ISO 3297: 2007 Certified Organization)

Vol. 5, Issue 10, October 2016

Where x is the non-overlapping block of size 8×8 from the host image and T is the computed non-overlapping block threshold value.

Frequency sensitivity:

The digital image is divided into 8×8 non-overlapping blocks and then DCT is applied to each block, then will get 8×8 matrix of DCT coefficients for each block of digital image. The 2D DCT matrix represents low frequency coefficients in the top left corner and high frequency coefficients are represented in the bottom right corner of the matrix. Middle frequency coefficients are represented by the diagonal elements of the matrix. The most of the energy content of the image is located in low frequency areas of the image. If low frequency coefficients of the image are modified, then the image distorted. If high frequency coefficients are used for embedding of watermark, then these watermarks can easily removed by image processing attacks such as image compression and cropping, etc., so middle frequency coefficients are used for embedding the watermark into the host image.

D. FUZZY INFERENCE SYSTEM

This FIS maps the input space to output space using fuzzy logic. Fuzzy logic is a type of many valued logic different from the binary valued logic. This process mainly involves using three pieces these are membership functions, linguistic variables, and if-then rules [4]. These FIS shown in Fig 2. Fuzzification means the conversion of input crisp value to a linguistic variable using different membership functions which are stored in the knowledge base of the FIS. Conversion of fuzzy input to the fuzzy output can be done by inference engine, this block Using If-Then type of inference rules which are stored in the knowledge base of the FIS. In Defuzzification, Conversion of the fuzzy output coming from the inference engine to crisp value using membership functions which are stored in the knowledge base. This de-fuzzifier block analogous to the fuzzifier block[9]. In my proposed work, FIS used nine inference rules.

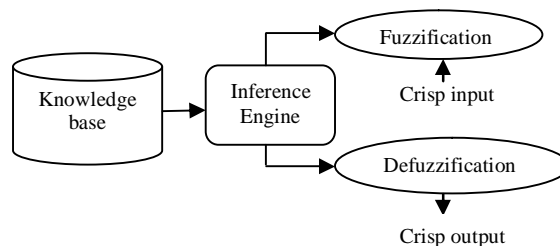

Fig 2: Fuzzy Inference System

E. BACK PROPAGATION NEURAL NETWORK (BPNN)

Each Artificial Neural Network can be formed as a group of layers. These layers are categorized into three types. These three layers are namely input layer, hidden and output layers. In a neural network, inputs are directly given as input to the input neurons and outputs are taken from output neurons. Processing of data can be performed in the hidden layers of the neural network. Each neuron has the activation function. In the proposed work, the sigmoid activation function used for all the neurons in the network. ANN is most suitable when training set of data be noise or sensed data. These ANN is inspired from the biological neural networks.

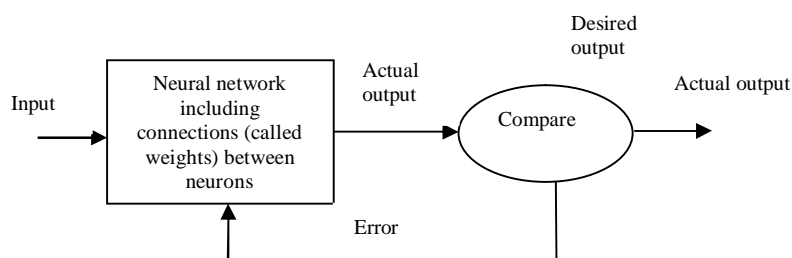

Fig.3: Operation of BPNN

International Journal of Innovative Research in Science, Engineering and Technology

(An ISO 3297: 2007 Certified Organization)

Vol. 5, Issue 10, October 2016

In BPNN, the learning algorithm can be done in these two phases, namely feed forward step and back propagation step. These two steps are explained below:

Feed-forward: The given input pattern is propagated from the input layer to output layer until the output pattern is generated from the output layer and these output patterns are stored.

Back propagation: When the actual getting output and desired (target) outputs, are different, then calculate the error between these two and back propagated this error from the output layer to input layer by adjusting all the weights in the neural network. This process is done several ways for reducing error between actual and desired outputs. In the proposed work, BPNN is used which is having one hidden layer with three hidden neurons.

IV. PROPOSED METHOD

Proposed embedding and extraction algorithms are explained below as.

A. EMBEDDING ALGORITHM

1. Read host color image of size 512x512 pixels.
2. Read watermark which is a binary image of size 32x64 pixels.
3. Extract one of the plane of the host image.
4. Apply 1-level Haar wavelet to the extracted plane of the host image.
5. Merge LH and HL sub bands.
6. Apply block based DCT to this merge band.
7. Calculate HVS parameters such as luminous sensitivity, Texture, Edge and Frequency sensitivity for each block.
8. Apply Luminous and Edge sensitivities as input to the FIS and then calculate the output values by using inference rule base.
9. Apply these calculated FIS outputs and Texture sensitivity as input to the BPNN which are trained for the frequency sensitivity values.

10. If $W(i)=1$
 $X(5,4,i)=y(i)+15$
 else
 $X(5,4,i) = y(i)-15$
 $X =$ new DCT coefficients after watermark embedding
 $y(i) =$ BPNN output
 $W(i) =$ Binary watermark image bits

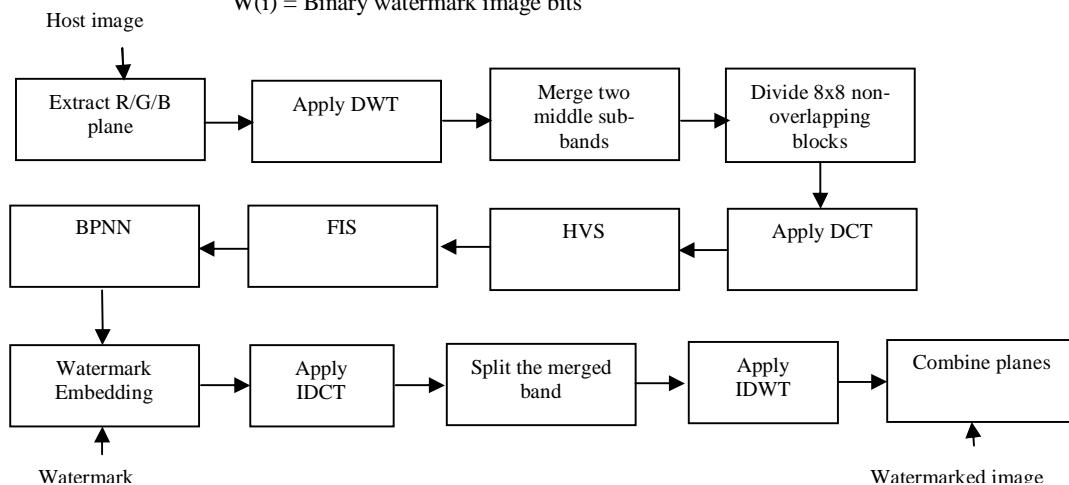

Fig. 4: Block diagram for embedding algorithm

11. Apply inverse DCT for each sub block and recombine all sub blocks to generate the merged band, split these merged band and then apply IDWT and combine with all planes to form the watermarked color image.

International Journal of Innovative Research in Science, Engineering and Technology

(An ISO 3297: 2007 Certified Organization)

Vol. 5, Issue 10, October 2016

B. EXTRACTION ALGORITHM

1. Extract plane of the watermarked image which is the same plane as in the embedding method.
2. Apply 1-level Haar wavelet to the extracted plane of the watermarked image.
3. Merge the LH and HL sub bands.
4. Apply block based DCT to this merge band.
5. Calculate HVS parameters for each block, i.e. Luminous, Texture, Edge and Frequency sensitivity values.
6. Apply Luminous and Edge sensitivities as input to the FIS then calculate the output values by using inference rule base.
7. Apply these calculated FIS outputs and Texture sensitivity as input to the neural network and simulate it.
8. Sort the output of BPNN in descending order.
9. Take each sub block and perform below procedure for extraction of watermark bits.
10. If $X(5,4,i)-y1(i)>0$
 $W'(i)=1$
 else
 $W'(i)=1$
 X = middle DCT coefficients of non-overlapping blocks
 $y1(i)$ = BPNN output
 $W'(i)$ = Binary watermark image bit
11. Rearrange the watermark bits and calculate Cross Correlation value for original and extracted watermark.

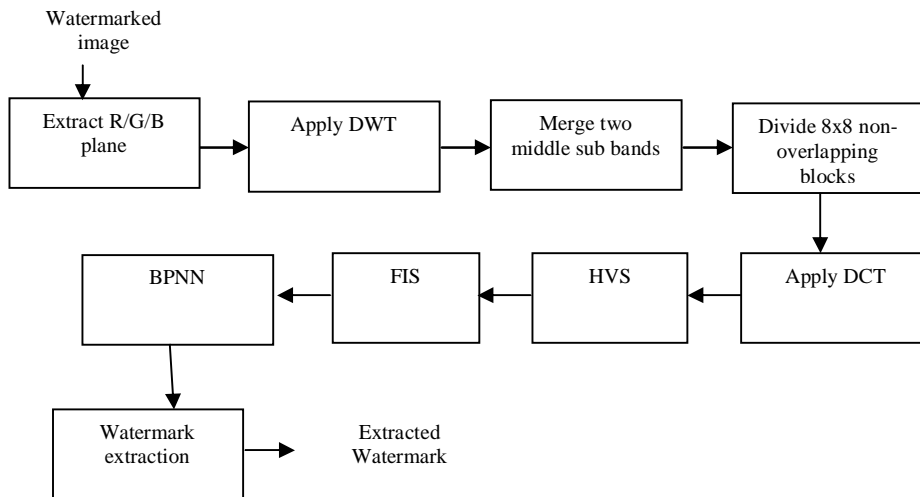

Fig5: Block diagram for extraction of watermark

V. EXPERIMENTAL RESULTS

The efficiency of the proposed method can be evaluated by using host image of size 512x512 pixels of a color image "LENA", shown below in Fig. 6(a) and binary watermark image of size 32x64 shown in Fig. 6(b). Watermarked image and extracted watermark are shown in Fig. 6(c) and (d) respectively.

International Journal of Innovative Research in Science, Engineering and Technology











(An ISO 3297: 2007 Certified Organization)

Vol. 5, Issue 10, October 2016



Fig. 6. Digital Image Watermarking (a) Original host image of size 512X512 (b) Binary watermark image of size 32X64 (c) DWT host image(Haar wavelet) of size 512X512 (d) Watermarked image of size 512X512 (PSNR=48.16dB) (e) Extracted watermark of size 32X64 (NCC=1)

This proposed method is tested for different image processing attacks which gives different PSNR and NCC values. These values can be shown in tabular form.

| s.no | Attack | PSNR | NCC | Extracted watermark |
|------|---------------------|-------|--------|---------------------------------------------------------------------------------------|
| 1 | No attack | 46.97 | 1 |  |
| 2 | Row blanking | 41.85 | 0.9948 |  |
| 3 | Column copy | 44.14 | 0.9874 |  |
| 4 | Rotation | 33.61 | 0.8773 |  |
| 5 | Salt & pepper noise | 45.35 | 0.7819 |  |
| 6 | Cropping | 30.41 | 0.8881 |  |
| 7 | Median filtering | 35.98 | 0.3347 |  |
| 8 | Resizing | 35.56 | 0.3616 |  |
| 9 | Gamma correction | 24.68 | 0.8535 |  |
| 10 | Bit plane removal | 42.25 | 0.9979 |  |

International Journal of Innovative Research in Science, Engineering and Technology

(An ISO 3297: 2007 Certified Organization)

Vol. 5, Issue 10, October 2016

| | | | | |
|----|---------------------------------|-------|--------|------------|
| 11 | Image contrast attack | 28.02 | 0.9853 | ECE |
| 12 | Gaussian noise | 33.58 | 0.9134 | ECE |
| 13 | Poisson noise | 31.81 | 0.9366 | ECE |
| 14 | Blurring | 36.43 | 0.6836 | ECE |
| 15 | Sharpening | 30.22 | 0.9895 | ECE |
| 16 | Intensity transformation attack | 26.90 | 0.9990 | ECE |

Table 1: Comparison of NCC and PSNR values for different attacks

VII. CONCLUSION

In this present work, the proposed algorithm is a robust, blind digital image watermarking method based on Fuzzy-BPNN system in hybrid transform domain i.e. combination of both DCT and DWT transform techniques. The bits of the binary watermark image are embedded into a middle transform coefficient of each block after applying the DCT to the merged band consisting of LH and HL sub bands. In this process, the host image does not distort by giving better PSNR values with all processing attacks. Experimental results shows that the proposed method is robust to many processing attacks by giving better NCC values and for transparency it yields good PSNR values. Median filtering and Resizing attacks give less NCC values when compared to other processing attacks. Gamma correction, Intensity transformation attacks gives less PSNR value.

REFERENCES

- [1] Charu Agarawal, Anurag Mishra, "A Novel Watermarking Technique using Fuzzy-BP Network", Sixth International Conference on Intelligent Information Hiding and Multimedia Signal Processing, pp 102-105, 2010.
- [2] Mehul S Raval, M V Joshi, Shubhalaxmi Kher, "Fuzzy Neural Based Copyright Protection Scheme for Super resolution", IEEE International Conference on Systems, Man, and Cybernetics, pp 328-332, 2013.
- [3] Cox, IJ, Miller, ML & Bloom, JA, "Digital Watermarking", Morgan Kaufmann Publisher, San Francisco, CA, USA, 2002.
- [4] Nallagarla Ramamurthy, Dr. S. Varadarajan, "Robust Digital Image Watermarking Scheme with Neural Network and Fuzzy Logic Approach", International Journal of Emerging Technology and Advanced Engineering, Volume 2, Issue 9, pp 555-562, September 2012.
- [5] B.Jagadeesh, D. P. Fuzzy-Neuro based Robust Digital Image Watermarking Technique. International Journal of Advanced Research in Computer and Communication Engineering, 3 (7) (2014).
- [6] Qiao Baoming, Zhang Pulin, Kang Qiao, "A Digital Watermarking Algorithm based on Wavelet Packet Transform and BP Neural Network", IEEE Seventh International Conference on Computational Intelligence and Security, pp 503-506, 2011.
- [7] Sameh Oueslati, Adnane Cherif, Basel Solaiman, "A Fuzzy Watermarking Approach Based on the Human Visual System", International Journal Of Image Processing (IJIP), Volume (4), Issue (3), 2011.
- [8] Miss.Hinal M. Mudia, Prof. Miss .P.V.Chavan, " Fuzzy Logic Based Image Encryption For Confidential Data Transfer Using (2, 2) Secret Sharing Scheme Review ", International Conference on Advances in Computer Engineering and Applications, 2015
- [9] Charu Agrawal, Anurag Mishra, Arpita Sharma, "Digital Image Watermarking in DCT Using Fuzzy Inference System", IEEE ICCECE, pp 822-825, 2011.
- [10] U.S.N. Raju, Kamalakanta Sethi, Sunaina Choudhary and Priyanka Jain, "A New Hybrid Watermarking Technique using DCT and DWT based on Scaling Factor", IEEE International Conference on Systems, pp 232-235, 2015
- [11] Changhoon Yim, Alan Conrad Bovik, "Quality Assessment of Deblocked Images", IEEE Transactions on Image Processing, Vol. 20, No. 1, pp. 88-98, January 2011.
- [12] Rafel C. Gonzalez, Richard E. Woods and Steven L.Eddins, "Digital Image Processing Using MATLAB", Pearson Education, pp 406-467, 2002.