

# **Design and Development of Power Monitoring and Controlling System using Wireless Zigbee Network**

Dr. Madhukar S. Chavan

Department of Electronics and Telecommunication Engineering, P.V.P Institute of Technology, Budhgaon,  
Sangli, India

**ABSTRACT:** The paper proposes design and development of a power monitoring system for monitoring electrical parameters such as voltage, current and consumed power by household appliances. The system consists of smart sensing units that detects and controls the electrical home appliances. Power Monitoring is well suited for managing energy cost and efficiency thereby improve utility of the home appliances. A developed prototype has been extensively tested. Monitoring system can limit the exposure of personnel to potentially hazardous environment. This study also aims to assess consumer's response towards perceptions of smart grid technologies, their advantages and disadvantages, possible concerns and overall perceived utility.

**KEYWORDS:** Zigbee, Optocoupler, AT89C52, Power monitoring.

## **I. INTRODUCTION**

Monitoring is the regular observation and recording of activities taking place at place. It is a process of routinely gathering information on all aspects of the project. To monitor is to check on how project activities are progressing. It is systematic and purposeful observation about power monitoring. Monitoring also involves giving feedback about the progress of the project to the donors, implementers and beneficiaries of the project. Reporting enables the gathered information to be used in making decisions for improving project performance. A power monitoring system is a network of meters that provides real time data on the power system in our facility. The owners and service providers are able to identify potential problems with the electrical systems. At home, the power monitoring has become more relevant due to the interest in energy saving and the energy efficiency. A developed prototype has been extensively tested. Power Monitoring is well suited for managing energy cost and efficiency thereby improve utility of the home appliances.

## **II. RELATED WORK**

The work proposed by Suryadevara N. K. and Gill P. S. [1] on smart grids utilizing wireless sensor network technologies are being promoted by US government as a way of addressing energy independence, global warming and emergency resilience issues. Home energy monitoring has been popular in the past, subsidized smart meter deployments will make it cost effective. The work proposed by Dae-Man Han, Jae-Hyun Lim [2] on wired sensor networks have already been reached and deployed in many applications over a decade. Because of the wireless extension, smart grids have witnessed a tremendous upsurge in interest and activities in recent years. All electrical equipments in facility are hooked to a meter. The meter is essentially a monitoring tool connected to the Internet. The aim of the system is to determine the areas of daily peak hours of electricity usage levels and come with a solution by which we can lower the consumption and enhance better utilization of resources during peak hours. The sensor networks have been programmed with user interfaces.

# International Journal of Innovative Research in Science, Engineering and Technology

(An ISO 3297: 2007 Certified Organization)

Vol. 5, Issue 10, October 2016

### III. TRANSMITTER

The block diagram of the transmitter is shown in fig.1. AT 89C52 microcontroller is heart of the system.

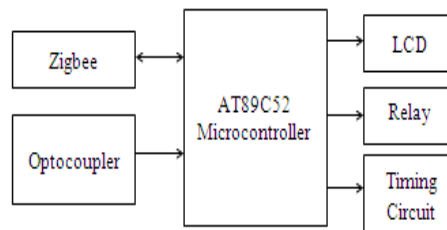

Fig.1 Transmitter

A microcontroller is a computer-on-a-chip. Micro suggests that the device is small and it might be used to control objects, processes or events. In test equipment, microcontrollers make it easy to add features such as the ability to store measurements, to create and store user routines and to display messages and waveforms. The Zigbee is the wireless sensor. It is used for the wireless communication between two nodes.. In this system encoded drawn text pattern or images are transmitted towards the receiver side by using Zigbee transmitter. The same type of Zigbee wireless sensor is used at receiver side for receiving purpose. Zigbee and IEEE 802.15.4 are designed for lightweight sensor platforms. Zigbee is a IEEE 802.15.4-based specification for a suite of high-level communication protocols used to create personal area networks with small, low-power digital radios. The technology defined by the Zigbee specification is simpler and less expensive than other wireless personal area networks (WPANs), such as Bluetooth or Wi-Fi. Its low power consumption limits transmission distances to 10–100 meters line-of-sight, depending on power output and environmental characteristics. Here 16x2 characters LCD display is used. 16x2 Character LCDs have their own restrictions; they can only display characters of certain magnitudes. Thus the Graphical LCD may be used to display modified characters and images. Relays are used for controlling the load. Here the transistorized driver circuits are used for relays. Relays are basically used To TURN ON/OFF high voltage or high current circuit using a low voltage signals e.g. turning ON/OFF motors using a microcontroller.

### IV. RECEIVER

The block diagram of the transmitter is shown in Fig.2.

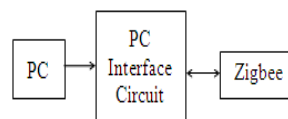

Fig.2 Receiver

Zigbee module includes low-IF receiver. The received RF signal is amplified by the low noise amplifier (LNA) and down- converted in quadrature (I and Q) to the intermediate frequency (IF). At IF, the I/Q signals are digitized by the ADCs. Automatic gain control (AGC), fine channel filtering, demodulation bit/packet synchronization are performed digitally. Micro-controller reads data from PC and it will transmit to Zigbee or it will receive data from Zigbee and transmit to PC. COM ports are used to output data from PC or input the data inside the PC.

# International Journal of Innovative Research in Science, Engineering and Technology

(An ISO 3297: 2007 Certified Organization)

Vol. 5, Issue 10, October 2016

## V. FLOWCHART OF THE COMPLETE SYSTEM

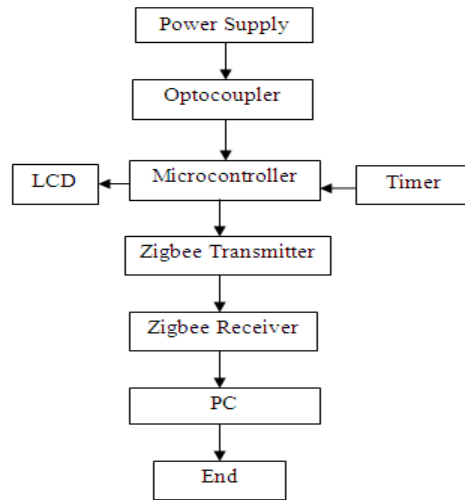

Fig.3 Flowchart of the complete system

The pulses from optocoupler are given them to the microcontroller. The microcontroller receives the count and stores in the memory. The pulses are compared with threshold and displayed on the LCD. The loads can be made be on and off on the basis of comparison. The data is provided to zigbee which will be transmitted on the receiver side, the zigbee will work as a receiver which will display the result on PC. The main advantage is that it is a transceiver in which we can use number of RF modules together. Other advantages of the system are: small size, low cost, reliable, power demand can be controlled easily, user friendly, optimal utilization of the power.

## VI. EXPERIMENTAL RESULTS

### A. SYSTEM WITHOUT LOAD

In the experiment we have used electric bulbs as load. Each bulb indicates power consumption in one room of the house.



Fig.4 System without load

# International Journal of Innovative Research in Science, Engineering and Technology

(An ISO 3297: 2007 Certified Organization)

Vol. 5, Issue 10, October 2016

The system without load indicates that no supply is applied to the system and system is inactive. We cannot get count of pulses.

## V. OUTPUT OF THE SYSTEM WITH LOAD

Fig.5 shows output of the system with load. When the power is applied, the load is switched on. Each bulb represents one of the four different rooms. There are four 40Watt bulbs. Energy meter is used to count the pulses.



Fig.5 Output of the system without load

The number of pulses can be displayed on LCD as well as on personal computer.

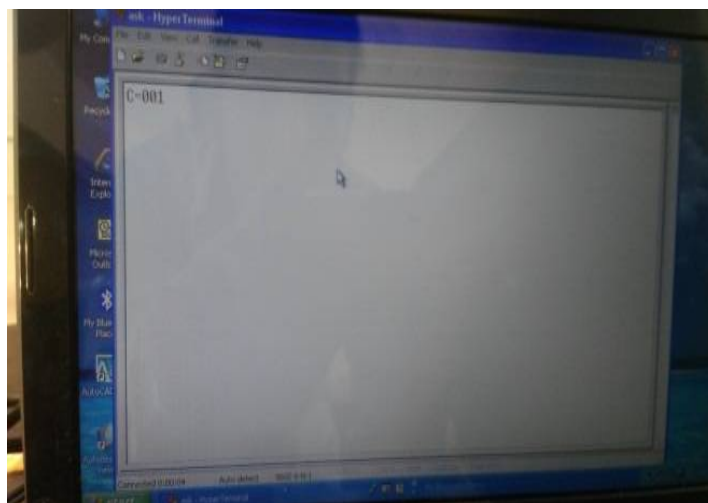

Fig.6 Display of Result

# International Journal of Innovative Research in Science, Engineering and Technology

(An ISO 3297: 2007 Certified Organization)

Vol. 5, Issue 10, October 2016

When percentage power condition is specified microcontroller checks condition after 30 seconds and gives output. We have used PL2305 software to check the output of each appliance.

The table 1 gives pulse counts for different loading conditions of the monitoring system. There are five different conditions of the system.

**Table 1: Different load conditions and related pulse counts.**

Sr. No.	Condition	Pulse Count	% of Power	LEDs
1	Press 1	Max.	100	All
2	Press 2	48	75	3
3	Press 3	32	50	2
4	Press 4	16	25	1
5	Press 5	0	0	0

If we press 1, output power is maximum (100%) and all LEDs are switched on. If we press 2, output power is 75% and only three LEDs are switched on. If we press 3, output power is 50% and only two LEDs are ON. If we press 4, output power is 25% and only one LED is on and lastly when we press 5, output power is zero and all the LEDs are switched off.

## VII. CONCLUSION

We conclude that the areas of daily peak hours of electricity usage levels and come with a solution by which we can lower the consumption and enhance better utilisation of already limited resources during peak hours. The sensor networks will be programmed with various user interfaces suitable for users of varying ability and for expert users such that the system can be maintained easily and interacted with very simply. This study also aims to assess consumer's response towards perceptions of smart grid technologies, their advantages and disadvantages, possible concerns and overall perceived utility. A developed prototype has been extensively tested. Power Monitoring is well suited for managing energy cost and efficiency thereby improve utility of the home appliances.

## REFERENCES

- [1] Suryadevara N. K. and Gill P. S., "Smart Power Monitoring System Using Wireless Sensor Network", Massey University, New Zealand, 2011.
- [2] Dae-Man Han, Jae-Hyun Lim, "Smart home energy management system using IEEE 802.15.4 and zigbee", IEEE Transactions on Consumer Electronics, Vol: 56, Issue: 3, 2010.
- [3] Li, Hu Xiaoguang, Huang Jian, He Ketai, "Design of new Architecture of AMR system in Smart Grid", Proceedings of the 6<sup>th</sup> IEEE Conference on Industrial Electronics and Applications (ICIEA), Page(s): 2025 – 2029, 2011.
- [4] V.N. Kamat, "Enabling an Electrical Revolution using Smart Apparent Energy Meters and Tariffs", Proceedings of the Annual IEEE- India Conference (INDICON), Page(s): 1 – 4, 2011.
- [5] E Andrey, J Morelli, "Design of a Smart Meter Techno-Economic Model for Electric Utilities in Ontario", Proceedings of the IEEE Electric Power and Energy Conference (EPEC), Page(s): 1 – 7, 2010.
- [6] F. Benzi, N. Anglani, E. Bassi, L. Frosini, "Electricity Smart Meters Interfacing the Households", IEEE Transactions on Industrial Electronics, Volume: 58, Issue: 10, 2011.
- [7] I. Kunold, M. Kuller, J. Bauer, N Karaoglan, "A System Concept of an Energy Information System in Flats Using Wireless Technologies and Smart Metering Devices", Proceedings of the IEEE 6th International Conference on Intelligent Data Acquisition and Advanced Computing Systems (IDAACS), Page(s): 812 – 816, 2011.
- [8] S. Nistor, Jianzhong Wu, M. Sooriyabandara, J. Ekanayake, "Cost Optimization of Smart Appliances", Proceedings of the 2<sup>nd</sup> IEEE International Conference and Exhibition on Innovative Smart Grid Technologies (ISGT Europe), 2011
- [9] Lixia Zhou, Xun Liao, Shunxin Li, Jincan Yuan, "Design and Development of the Reliability Prediction Software for Smart Meters", Proceedings of the International Conference on Quality, Reliability, Risk, Maintenance, and Safety Engineering (ICQR2MSE), Page(s): 612 – 616, 2012.
- [10] N. H. Maghsoodi, M. Haghnegahdar, A. H. Jahangir, E. Sanaei, "Performance Evaluation of Energy Management System in Smart home using Wireless Sensor Network", Proceedings of the 2<sup>nd</sup> Iranian Conference on Smart Grids (ICSG), Page(s): 1 – 8, 2012.