

Enhancing Power Quality to Sensitive Loads with Microgrid Using Fuzzy Logic Controller

B.Vineel¹, Dr.D.Vijaykumar², K.S.Goutham³, J Vijaychandra⁴

P.G. Student, Department of EEE, AITAM Engineering College (Autonomous), Andhra Pradesh, India¹

Professor, Department of EEE, AITAM Engineering College (Autonomous), Andhra Pradesh, India²

Asst. Professor, Department of EEE, AITAM Engineering College (Autonomous), Andhra Pradesh, India³

P.G. Student, Department of EEE, AITAM Engineering College (Autonomous), Andhra Pradesh, India⁴

ABSTRACT: This paper presents the effectiveness of a microgrid(MG) in a distribution system.the combined Heat and Power (CHP) system is used to enhance the overall efficiency of the power system.Microturbines are used for combined heat and power operation in this paper.The various methods of the MG are discussed.A simple low cost model is proposed for MG based on frequency droop control for active power generation.The proposed model can be used in plug and play mode of operation of the MG.The model of MG is developed and its performance is simulated in MATLAB platform. Performance of the model is studied under grid connected and under islanded conditions.

KEYWORDS: Combined Heat and Power applications (CHP), Distributed Generation (DG), droop control method, Microgrid (MG), Microsource (MS), Power Quality

I.INTRODUCTION

TODAY, several mission critical loads are present on the power system which require quality power for their proper functioning. Popular technologies which provide quality power, during the failure of grid, include use of Microturbines, fuel cells, as well as renewable energy sources like solar Photo Voltaic (PV) and wind power. These small generators, dispersed throughout the power system, have been used primarily for backup and were not synchronized to the grid power supply. Furthermore, they were not interconnected. There has been a trend to change the role of this Distributed Generations (DG) from backup to primary energy supply and to have flexible interconnection strategies. The concept of Microgrid (MG) has thus grown out of this desire for a flexible interconnected system. A MG on the low voltage (LV) distribution is an appropriate solution for (a)The customer with mission critical loads receiving quality power and (b) the Distribution Network Operators (DNOs) as relief for their already overloaded system. DGs are emerging as new paradigm to produce onsite, highly reliable and good quality power. The power system is going through a rapid growth with the connection of DGs in the distribution system. Transmission through pipes is slowly and surely replacing the age old concept of transmission through wires. One of the most promising applications of this new concept corresponds to the Combined Heat and Power (CHP) application leading to an increase of the overall energy utilization in the total system. This is due to the fact that compared to the electricity transmission, transporting low grade recovered heat is prohibitively expensive relative to its net economic value. Thus generating close to potential user of waste heat has a compelling attraction .The installation of DG has enabled the DNOs to postpone incurring expenditure on expansion of the transmission and distribution network.

II.RELATED WORK

Depending on the type of load requirements, Microgrids can operate with ac or dc power, resulting in ac or dc Microgrids. The coexistence of ac and dc subgrids in a hybrid Microgrid is proposed by Loh et al. Control strategies for MG islanded operation have been discussed by Lopes et al. Controller design and optimization method of a

Microgrid is presented by Chung et al. An ac-ac matrix converter has been utilized to interface high speed Microturbine generator to utility grid as distributed generation unit. Lately, the concept of virtual flux has been introduced by Hu et al for droop control of Microgrid voltage and frequency. In this paper, an attempt has been made to model the MG in a manner which is simple, with control schemes that has matured in the industry and involves less expenditure. Any addition or removal of a DG from the MG is a plug and play matter. Furthermore, the performance of the proposed MG under both grid-connected and islanded condition is also investigated.

III. CONFIGURATION OF THE PROPOSED SYSTEM

The configuration of the proposed system was shown in the figure. The descriptions of various systems was explained in this paper.

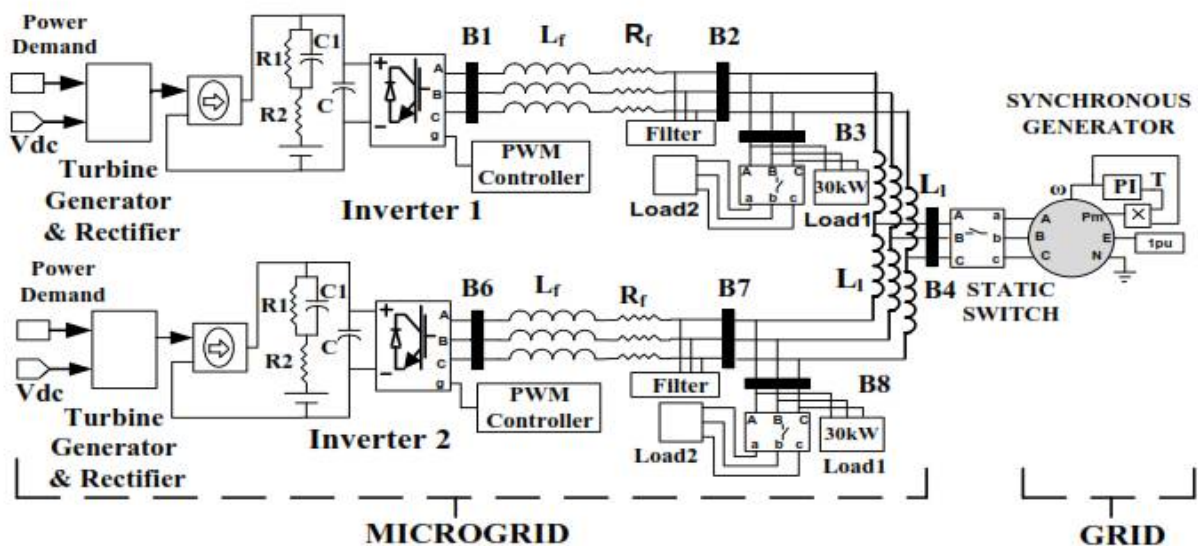

FIGURE: The configuration of the proposed system

WIND ENERGY: Wind is abundant almost in any part of the world. Its existence in nature caused by uneven heating on the surface of the earth as well as the earth's rotation means that the wind resources will always be available. The conventional ways of generating electricity using non renewable resources such as coal, natural gas, oil and so on, have great impacts on the environment as it contributes vast quantities of carbon dioxide to the earth's atmosphere which in turn will cause the temperature of the earth's surface to increase, known as the green house effect. Hence, with the advances in science and technology, ways of generating electricity using renewable energy resources such as the wind are developed. Nowadays, the cost of wind power that is connected to the grid is as cheap as the cost of generating electricity using coal and oil. Thus, the increasing popularity of green electricity means the demand of electricity produced by using non renewable energy is also increased accordingly.

MICROGRID:

A Microgrid, a local energy network, offers integration of distributed energy resources (DER) with local elastic loads, which can operate in parallel with the grid or in an intentional island mode to provide a customized level of high reliability and resilience to grid disturbances. This advanced, integrated distribution system addresses the need for application in locations with electric supply and/or delivery constraints, in remote sites, and for protection of critical loads and economically sensitive development.

A Microgrid is any small or local electric power system that is independent of the bulk electric power network. For example, it can be a combined heat and power system based on a natural gas combustion engine (which

cogenerates electricity and hot water or steam from water used to cool the natural gas turbine), or diesel generators, renewable energy, or fuel cells. A Microgrid can be used to serve the electricity needs of data centers, colleges, hospitals, factories, military bases, or entire communities.

SYNCHRONOUS AC GENERATOR: The Synchronous speed will be in the range of 1500 rpm – 4 pole, 1000 rpm – 6 pole or 750 rpm, - 8 pole for connection to a 50 Hz net work. The ingress of moisture is to be avoided by providing suitable protection of the generator. Air borne noise is reduced by using liquid cooling in some wind turbines. An increase of the damping in the wind turbine drive train at the expense of losses in the rotor can be obtained by high slip at rated power output. Synchronous generators run at a fixed or synchronous speed, N_s . We have $N_s = 120 f / p$, where p is the number of poles, f is the electrical frequency and N_s is the speed in rpm.

IV.CONTROL SYSTEMS

Control of MG with Inverter Interface:

There are several energy sources like fuel cells, solar PV units, Microturbines etc. (popularly called MicroSources or MS) which produce dc output or produce electrical output at frequencies not compatible with the grid frequency.

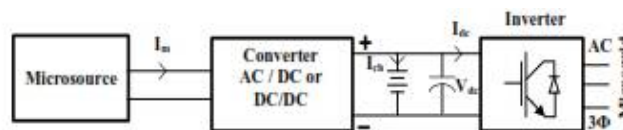

The micro source is made to charge a battery which inturn feeds power to the micro grid.through an inverter.Moreover it will be assumed that if the power demand is within the capability of the device, the dc voltage is kept constant by the primary generator controls.

Inverter Control:

The model of the inverter connecting the MS to the MG is shown in the Figure. The plug and play operation of the MS in a MG imposes conditions that new MS can be added to the system without modification of the existing equipments.

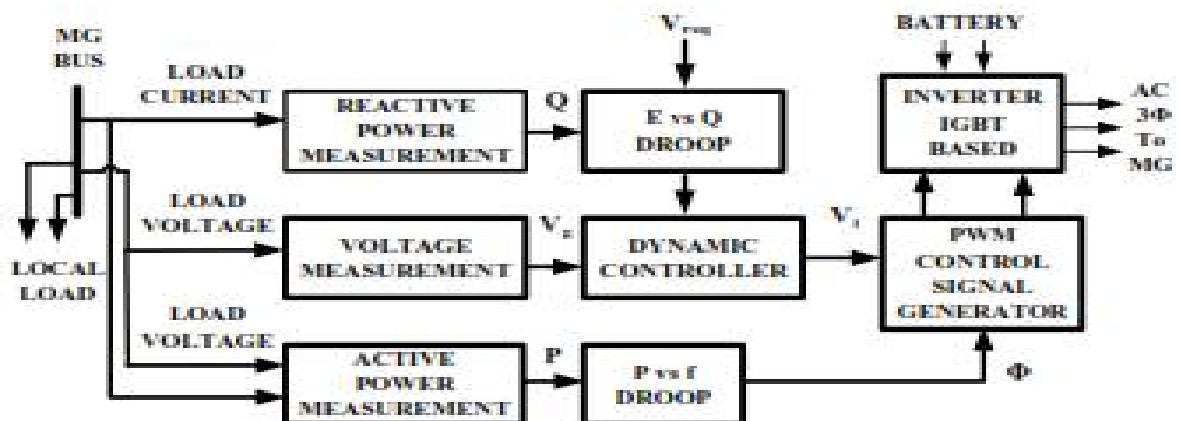

The MSs autonomously choose their set points. Further, the MG has the capability to isolate itself from the utility grid or connect to it in a rapid and seamless fashion. The MS follow the dynamic changes of the local loads and autonomously control the active power produced by them. Each MS have autonomous control without requiring data from the loads, the static switch or other sources.

International Journal of Innovative Research in Science, Engineering and Technology

(An ISO 3297: 2007 Certified Organization)

Vol. 5, Issue 10, October 2016

CENTRALLY CONTROLLED MICROGRID:

A MG Central Controller (MGCC) installed on grid substation at the PCC, centrally controls the MG operation. It sends control signals to the second level of controllers, such as those at group of loads (Load Controller or LC) or controllers located at MS (Microsource Controller or MC). Depending on the economic managing function, stability control and other functionalities that are built into the MGCC, it communicates with the LC and MC and provides set points to both LC and MC.

AUTONOMOUS CONTROL:

Each MS on the MG has its own autonomous control. There is no component, such as master controller or central storage unit which may be critical for the operation of the MG. This model has an advantage that the MS can be connected at any point on the MG, which will allow a plug and play operation model for each component of the MG. Further, with one MS more than the quantity required for meeting the total load on the MG, greater security and reliability of the MG can be ensured in the event of loss of a MS. This control architecture is discussed later for the control of the MG.

UNIT POWER CONTROL:

In this mode of operation, each MS regulates the voltage at its output terminal, which is also the point where it is connected to the grid. The MS sources a constant power into its connection point in grid connected mode. If the load increases anywhere in the MG, the extra power is drawn from the utility grid. This mode supports the CHP mode of operation because production of power depends on the heat demand. Electricity is then generated at higher efficiencies. When the MG islands itself, the MS's frequency droop ensures that the power requirement of all loads is met within the MG.

V.SIMULATION RESULTS

The performance of the proposed MG comprising of Microturbines and voltage source inverters and further connected to the utility grid modeled by a synchronous generator for equal and unequal loads was shown in the figures.

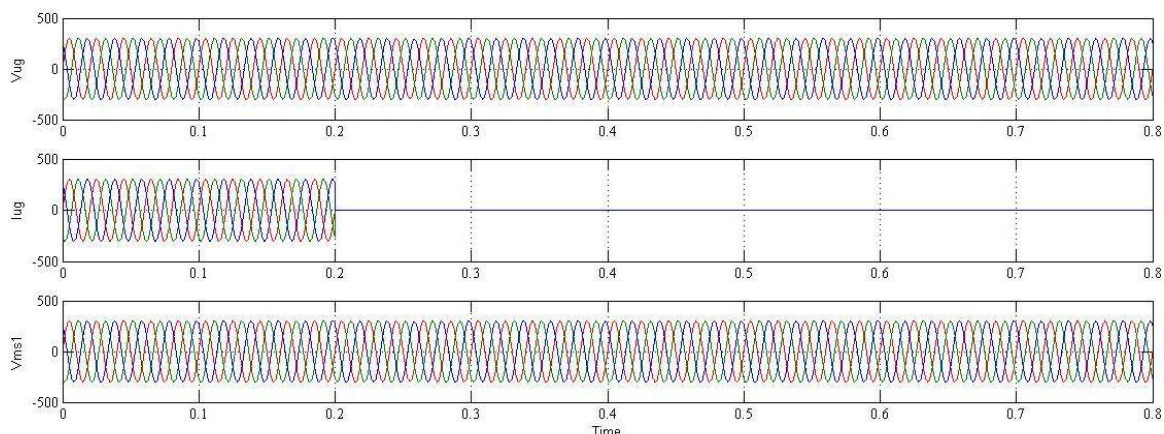

The figure shows the performance of microgrid connected to the utility grid with equal loads on both microsources. V_{UG} represents grid bus voltage, I_{UG} represents grid bus current and V_{ms1} represents microsource 1 output voltage.

International Journal of Innovative Research in Science, Engineering and Technology

(An ISO 3297: 2007 Certified Organization)

Vol. 5, Issue 10, October 2016

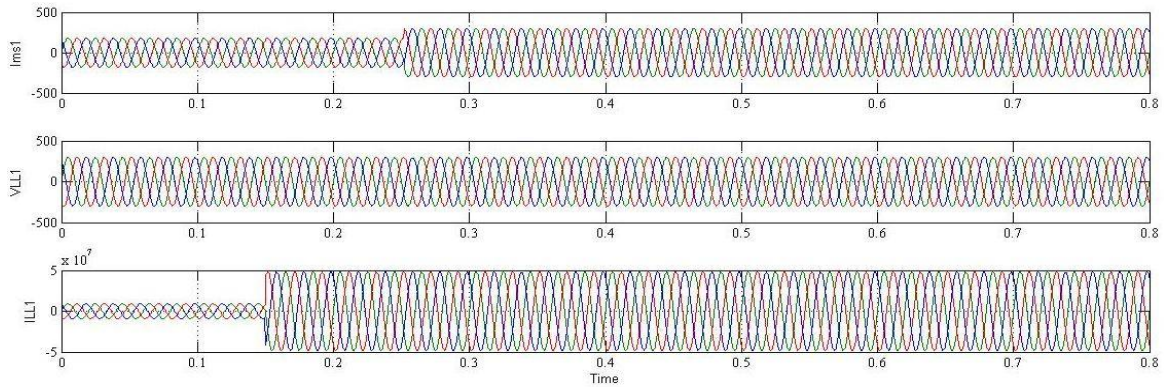

The figure shows the performance of the proposed microgrid comparison of micro turbines, VSI and further connected to the utility grid modeled by synchronous generator. I_{ms1} represents microsource1 output current, V_{LL1} represents local load voltage of microsource1, I_{LL1} represents current flowing into the local load.

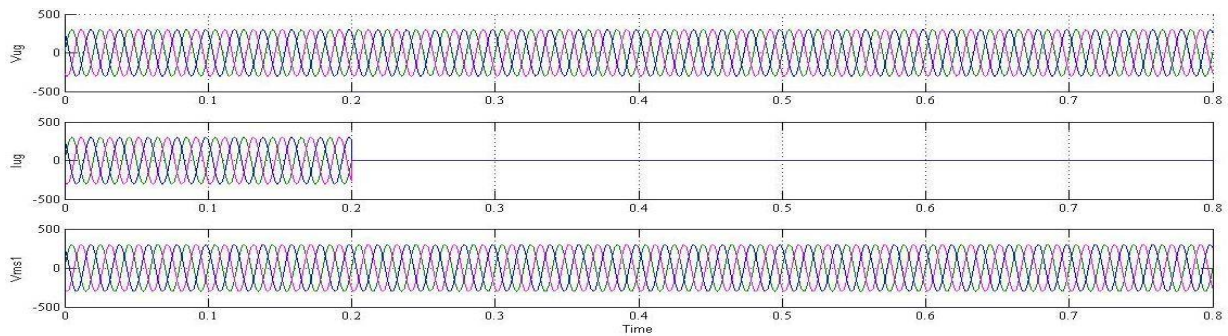

The figure shows the performance of microgrid connected to the utility grid without equal loads on both microsources. V_{UG} represents grid bus voltage, I_{UG} represents grid bus current and V_{ms1} represents microsource1 output voltage.

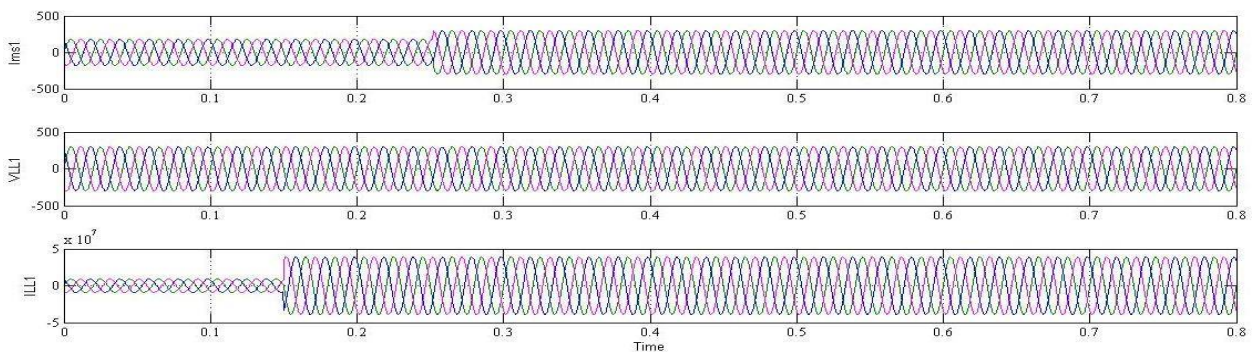

The figure shows the performance of the proposed microgrid comparison of micro turbines, VSI and further connected to the utility grid modeled by synchronous generator. I_{ms1} represents microsource1 output current, V_{LL1} represents local load voltage of microsource1, I_{LL1} represents current flowing into the local load.

International Journal of Innovative Research in Science, Engineering and Technology

(An ISO 3297: 2007 Certified Organization)

Vol. 5, Issue 10, October 2016

VI.CONCLUSIONS

A simple and low cost control method using parallel inverters on a MG using Fuzzy controller has been proposed. The proposed control method has also allowed plug and play operation when the MS is added or removed from the MG. The use of the frequency droop method has provided for the control of the MG without the use of expensive and complex communication system between the MSs. Simulation results have shown that the MG can function properly with the proposed type of droop control. The results of simulation have further demonstrated that the proposed MG works in appropriate manner for mission critical loads, where it is essential to provide quality power and accommodate load changes within a very short time. Future work can be attempted to reduce the distortions at the time of step load changes.

REFERENCES

- [1] R. C. Dugan, M. F. McGranaghan, S. Santoso and H. W. Beaty, "Electrical Power Systems Quality," 2nd ed. Tata McGraw-Hill Education, New Delhi, 2008.
- [2] A. Ghosh and G. Ledwich, "Power Quality Enhancement using Custom Power Devices," Kluwer Academic Publisher, Boston, 2002.
- [3] A. K. Saha S. Chowdhury, S. P. Chowdhury and P. A. Crossley, "Modeling and performance analysis of a microturbine as a distributed energy resource," *IEEE Trans. Energy Conversion*, vol.24, no. 2, pp. 529 -538, Jun. 2009.
- [4] P. Chiredeja and R. Ramakumar, "An approach to quantify the technical benefits of distributed generation," *IEEE Trans. Energy Conversion*, vol. 19, no. 4, pp. 764-773, Dec. 2004.
- [5] R. Lasseter, A. Akhil, C. Marnay, J. Stephens, J. Dagle, R. Guttromson, A. S. Meliopoulos, R. Yinger and J. Eto, "White paper on Integration of Distributed Energy Resources, The CERTS MICROGRID Concept" Consultant Report California Energy Commission, U.S. Department of Energy, Berkeley, CA, LBNL-50829, Apr. 2002.
- [6] N. Hatziairgiou, H. Asano, R. Iravani and C. Marnay, "Microgrids," *IEEE Power and Energy Magazine*, vol. 5, no. 4, pp.78-94, Jul/Aug 2007.
- [7] P. C. Loh, D. Li, Y. K. Chai and F. Blaabjerg, "Autonomous control of interlinking converter with energy storage in hybrid AC-DC microgrid," *IEEE Trans. Industry Applications*, vol.49, no.3, pp. 1374-1382, May/June 2013.
- [8] J. A. P. Lopes, C. L. Moreira and A. G. Madureira, "Defining control strategies for microgrids islanded operation," *IEEE Trans. Power Systems*, vol. 21, no. 2, pp.916-924, May 2006.
- [9] I. Y. Chung, W. Liu, D. A. Cartes, E. G. Collins Jr. and S. I. Moon, "Control methods of inverter-interfaced distributed generators in a microgrid system," *IEEE Trans. Industry Applications*, vol.46, no.3, pp. 1078-1088, May/June 2010.
- [10] K. D. Brabandere, B. Bolsens, J. V. d. Keybus, A. Woyte, J. Driesen and R. Belmans, "A voltage and frequency droop control method for parallel inverters," *IEEE Trans. Power Electronics*, vol. 22 no. 4, pp. 1107- 1115, Jul. 2007.
- [11] H. Nikkhajoei and M. R. Iravani, "A matrix converter based microturbine distributed generation system" *IEEE Trans. Power Delivery*, vol.20, no. 3, pp. 2182-2192, Jul. 2005.
- [12] J. Hu, J. Zhu, D. G. Dorrell, J. M. Guerrero, "Virtual flux droop method - a new control strategy of inverters in microgrids," *IEEE Trans. Power Electronics*, vol.29, no.9, pp. 4704 – 4711, Sept 2014.
- [13] B. Singh and G. K. Kansal, "Solid state controller for an isolated wind energy conversion system feeding dynamic loads," in *8th International Power Engineering Conference, (IPEC 2007)*, 2007, pp.532-537.

BIOGRAPHY



Mr.B.Vineel received his B.Tech Degree in Electrical and Electronics Engineering from Aditya Institute of Technology and Management, Tekkali, Andhra Pradesh, India in 2014. Currently pursuing M.Tech in Aditya Institute of Technology and Management,(Autonomous), Tekkali, Andhra Pradesh, India. His research interests include Power electronics.

International Journal of Innovative Research in Science, Engineering and Technology

(An ISO 3297: 2007 Certified Organization)

Vol. 5, Issue 10, October 2016



Dr.D.Vijaya Kumar completed his graduation in Electrical and Electronics Engineering from Andhra University, Visakhapatnam in 1997 and received his M.E. and Ph.D in Power Systems and Control systems from Andhra University, India in 2000 and 2010 respectively. He served as an Assistant Professor and Associate Professor in various Engineering colleges during 2000-2010 and at present, he is working as a Professor in the Department of Electrical and Electronics Engineering in AITAM College of Engineering, Tekkali, Andhra Pradesh, India. He had published many papers in national and international journals and conferences. His areas of interest are Power systems and Control systems.



Mr.K.S.Gowtham completed his graduation in Electrical and Electronics Engineering from Audisankara college of Engineering and Technology, Gudur, in 2008 and received his M.Tech in Power Systems from NIT Jamshedpur, India in 2010. He had a teaching experience of 6 years. He presently working as an Assistant Professor in the Department of Electrical and Electronics Engineering, AITAM College of Engineering, Tekkali, Andhra Pradesh, India. His areas of interest are Power systems and Electrical Machines.



Mr.J.Vijaychandra received his B.Tech Degree in Electrical and Electronics Engineering from Aditya Institute of Technology and Management, Tekkali, Andhra Pradesh, India in 2014. Currently pursuing M.Tech in Aditya Institute of Technology and Management, (Autonomous), Tekkali, Andhra Pradesh, India. His paper was selected in a conference "IEEE scopes 2016" conducted in CUTM, Orissa, India. His research interests include Renewable energy systems and power electronics.