

# Computer - Aided Evaluation of Steam Power Plants Performance Based on Energy and Exergy Analysis

Ahmed Noaman Ahmed Kamal El-Zayati<sup>1</sup>, Eed A. Abdel-Hadi<sup>2</sup>, Sherif H. Taher<sup>2</sup>, Islam H. Abdel-Aziz<sup>3</sup>

P.G. Student, Dept. of Mechanical Engineering, Shobra Faculty of Engineering, Benha University, Egypt<sup>1</sup>

Professor, Dept. of Mechanical Engineering, Shobra Faculty of Engineering, Benha University, Egypt<sup>2</sup>

Associate Professor, Dept. of Mechanical Engineering, Faculty of Engineering, Fayoum University, Egypt<sup>3</sup>

**ABSTRACT:** This paper aims to solve the power consumption problem by analysing the steam power plants from the energetic and exergetic viewpoint using computer application method. Most of the previous applications have some specificities which cannot be applied to any steam power plant. Moreover, they neglect the volumetric analysis of the hydrocarbon fuel which has a considerable effect on the boiler and power plant efficiencies. So, the first author built a new computer program called Energy and Exergy Analyses (EEA) which covers the shortage and overcomes the problems of the previous programs. We used it to analyse the increment problem of the fuel consumption occurred in the Cairo West Thermal Power Plant (Units 7 & 8). The results presented by EEA show that the boiler is the main source of exergy destruction due to combustion, boiling and superheating processes. Finally, we recommended some modifications to increase the power plant efficiency.

**KEYWORDS:** EEA, Energetic, Exergetic, analysis, Efficiency, Steam power plant.

## I. INTRODUCTION

Energy is the cornerstone of the economic development, so it is bound to re-examine the energy policies and take drastic steps in order to cope with the growing energy consumption. As a result of researches on this topic, it appears that there will be a massive increment in the energy consumption which will be led by The Non-OECD (Non Organisation for Economic Co-operation and Development) countries in the next two decades [1].

One way used to overcome the power consumption problem is to study the management of power production in steam power plants. By focusing on these plants, it is found that significant part of power is lost without any benefit from it which means that companies pay much money for less power. The previous studies analysed the power plants from the first law of thermodynamics point of view which concerns with the quantity of energy. Also, many of these studies adopt the second law of thermodynamics in the analysis because it concerns with the quality of energy.

This paper proposes a new program called EEA which built by the first author only. It can be applied to evaluate the performance of power plants depending not only on the first law of thermodynamics but also the second law of thermodynamics. Users will supply the operating parameters to the program to get the energy and exergy of the power plants. The program determines which system causes the most energy and exergy losses, allowing researchers to focus their efforts on improving their designs. Moreover, it calculates the energy and exergy efficiencies of the different systems in the power plant. Furthermore, EEA calculates the overall energy and overall exergy efficiencies of the power plant. It introduces the results in tables and charts in order to facilitate the results analyses. Finally, recorded data of Cairo West Thermal Power Plant is used to evaluate and show the capabilities of the new program.

# International Journal of Innovative Research in Science, Engineering and Technology

(An ISO 3297: 2007 Certified Organization)

Website: [www.ijirset.com](http://www.ijirset.com)

Vol. 6, Issue 2, February 2017

## II. LITERATURE REVIEW

Sato [2] presents an introduction to the chemical thermodynamics for engineers discussing the total exergy of substances which composed of a physical part and a chemical part. Moreover, the thermodynamic laws and the aspects of energy, entropy, and exergy are covered in detail by Dincer and Rosen [3]. Furthermore, Moran [4] presented the thermal system design from the second law point of view. Also, Aljundi [5], Ameri, et al. [6] and Afifi [7] found that the main system responsible for energy destruction is the condenser and the boiler is the main system responsible for the exergy destruction. Moreover, Afifi [7] proved that using the fuel oil as the main fuel, achieving the greatest exergy efficiency of the combustion process. Moreover, Altayib [8] found that “the overall plant energetic and exergetic efficiencies increased by 20% and 12%, respectively, with cooling down the compressor inlet temperature to 10oC”. Also, he found that the major exergy loss was found in the combustion chamber. Ameri, et al. [9] found that the combustion process is the reason for the major exergy loss and the losses in the heat recovery steam generator (HRSG) come in the second place. Finally, they demonstrated that despite the output power increased by adding a duct burner to HRSG, the energy and exergy efficiencies decreased.

Ahmadi and Toghraie [10] performed energy and exergy analyses of Shahid Montazeri Power Plant using EES (Engineering Equation Solver) software. Moreover, Singh et al. [11] developed a C++ code for iterative calculations used in energy and exergy analyses of a 250MW thermal unit in Bhilai, India. Furthermore, Ahmadi and Dincer [12] developed a simulation program using Matlab software in order to find the best design parameters for Shahid Salimi gas turbine power plant in Neka, Iran. Finally, a computer program, written in Turbo Pascal, is presented by Fungtammsan, et al. [13]. The results show that the major energy destruction in the boiler is due to the energy carried out with flue gases. Finally, they emphasise that the combustion process is the main reason for the exergy destruction.

## III. EEA SOFTWARE AND THERMODYNAMIC ANALYSIS

The first author proposed and built a computer program, EEA, to get the energy and exergy analyses of the steam power plants. It is written using an Object Oriented Programming language (Microsoft Visual C#) with the aid of Microsoft Excel and SAP Crystal Reports. Moreover, the visual basic code of X-Steam Tables is converted into visual C# code and used to get the thermodynamic properties of the water and steam streams. Finally, a new code is added to get the specific entropy of the points in the wet region of the h-s water diagram.

EEA covers the shortage and overcomes the problems of the previous programs. It has an interactive form containing many systems which not mentioned in the earlier programs. Moreover, it is applicable to any steam power plant. It covers a wide range of hydrocarbon fuels which used in the combustion process then uses them to generate the fuel model. It calculates the reversible, isentropic and the actual power of main equipment of the plant. EEA calculates the thermal properties of all supplied streams. It shows the thermal efficiency of the power plant based on the lower and higher heating values. Furthermore, it shows the exergetic destruction and efficiency of the power plant. It lists the power and exergy destruction (loss) in many systems in the power plant. It presents the exergetic efficiency and destruction of each system and makes a comparison among them. As the boiler is a major and important system in the power plant, EEA presents its results in detail. It shows the gross and fuel energy efficiencies of the boiler. It shows the generated fuel model and its specifications. It presents the combustion process formula of the fuel in the stoichiometric and actual cases. It lists the air-fuel ratio and the adiabatic flame temperature. It produces the results in tables and charts to facilitate the analyses of these results. Finally, EEA is used to study the energy and exergy analysis of the Cairo West Thermal Power Plant (Units 7 & 8) in order to show its capabilities.

Cairo West Thermal Power Plant (Units 7 & 8) is a regenerative power plant which located in Egypt. It consists of two units. Each unit used to generate 350 MW of electricity and supply it to the Egyptian National Grid of Electricity. The main single line diagram of the Cairo West Thermal Power Plant is illustrated in Figure 1. It shows that the condensate water, which extracted from the condenser, is pumped to the deaerator through the low-pressure heaters (LPH 1 and 2 and LPH 3). Booster pumps raise the pressure of the feed-water and supply it to the main pumps through heater 5 and heater 6. Then main pumps increase the feed-water pressure and supply it to the boiler through heater 7 and heater 8. Boiler generates the superheated steam and delivers it to the high-pressure turbine. The steam is used to operate the

## International Journal of Innovative Research in Science, Engineering and Technology

(An ISO 3297: 2007 Certified Organization)

Website: [www.ijirset.com](http://www.ijirset.com)

Vol. 6, Issue 2, February 2017

steam turbine which rolls the generator to produce the electrical power. The condensed steam is collected and stored at the bottom of the condenser in the hot well to start the feed-water cycle again.

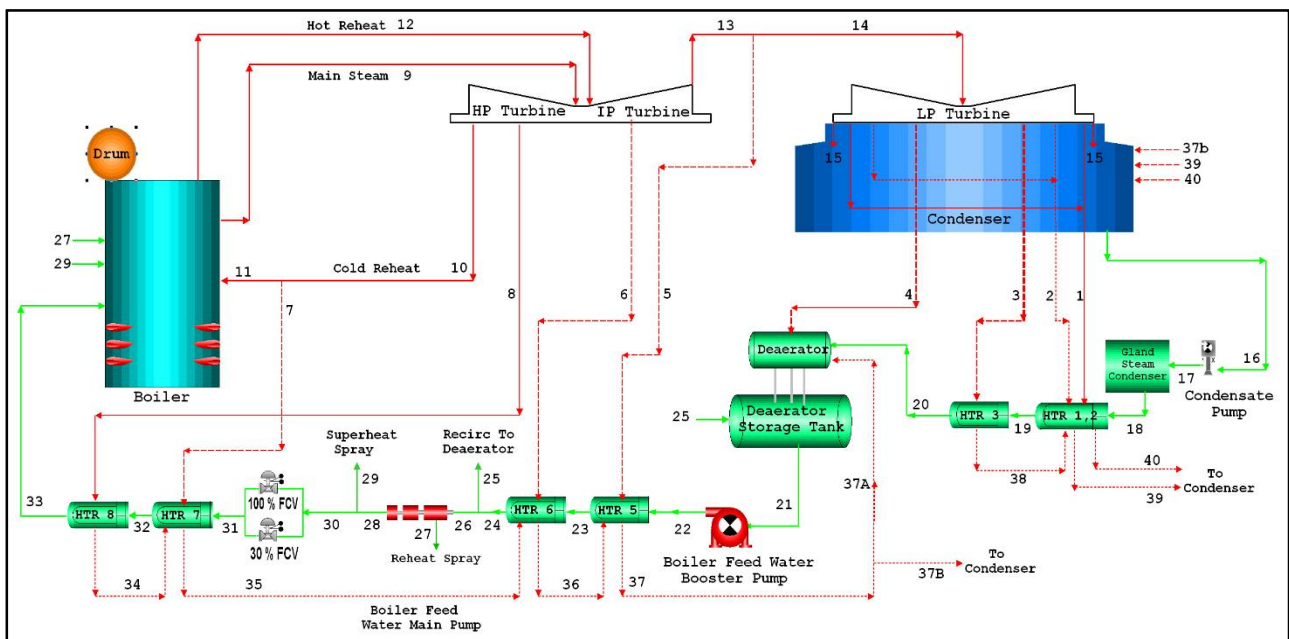

Fig. 1: Power plant layout.

We made energy and exergy model of the power plant and presented it in Table 1. It presents the thermodynamics model of the main systems of the power plant. It shows the fuel and the product of each system. Moreover, it shows the exergetic destruction and the exergetic efficiency of these systems. Furthermore, the isentropic, theoretical and reversible power of pumps and turbines are supplied. Finally, the power plant net power, thermal and exergetic efficiency are listed.

Table 1: Thermodynamics model of main components of Cairo West Thermal Power Plant (Units 7 & 8)

System	Thermodynamics Model	System	Thermodynamics Model
Turbine	$\eta_{isen} = \frac{\dot{W}_{Calc}}{\dot{W}_{isen}}$ Fuel = $\dot{W}_{rev}$ , Product = $\dot{W}_{Calc}$ $\dot{I} = \dot{W}_{rev} - \dot{W}_{Calc} , \quad \eta_{II} = \frac{\dot{W}_{Calc}}{\dot{W}_{rev}}$	High-Pressure Turbine	$\dot{W}_{isen} = \dot{m}_9 \cdot h_9 - \dot{m}_8 \cdot h_{8,isen} - \dot{m}_{10} \cdot h_{10,isen}$ $\dot{W}_{rev} = \dot{E}x_9 - \dot{E}x_8 - \dot{E}x_{10}$ $\dot{W}_{Calc} = \dot{m}_9 \cdot h_9 - \dot{m}_8 \cdot h_8 - \dot{m}_{10} \cdot h_{10}$
Intermediate Pressure Turbine	$\dot{W}_{isen} = \dot{m}_{12} \cdot h_{12} - \dot{m}_6 \cdot h_{6,isen} - \dot{m}_{13} \cdot h_{13,isen}$ $\dot{W}_{rev} = \dot{E}x_{12} - \dot{E}x_6 - \dot{E}x_{13}$ $\dot{W}_{Calc} = \dot{m}_{12} \cdot h_{12} - \dot{m}_6 \cdot h_6 - \dot{m}_{13} \cdot h_{13}$	Low-Pressure Turbine	$\dot{W}_{isen} = \dot{m}_{14} \cdot h_{14} - (\dot{m}_1 \cdot h_{1,isen} + \dot{m}_2 \cdot h_{2,isen} + \dot{m}_3 \cdot h_{3,isen} + \dot{m}_4 \cdot h_{4,isen} + \dot{m}_{15} \cdot h_{15,isen})$ $\dot{W}_{rev} = \dot{E}x_{14} - \dot{E}x_1 - \dot{E}x_2 - \dot{E}x_3 - \dot{E}x_4 - \dot{E}x_{15}$ $\dot{W}_{Calc} = \dot{m}_{14} \cdot h_{14} - \dot{m}_1 \cdot h_1 - \dot{m}_2 \cdot h_2 - \dot{m}_3 \cdot h_3 - \dot{m}_4 \cdot h_4 - \dot{m}_{15} \cdot h_{15}$

## International Journal of Innovative Research in Science, Engineering and Technology

(An ISO 3297: 2007 Certified Organization)

Website: [www.ijirset.com](http://www.ijirset.com)

Vol. 6, Issue 2, February 2017

Pumps	$\eta_{isen} = \frac{\dot{W}_{isen}}{\dot{W}_{calc}}$ Fuel = $\dot{W}_{calc}$ , Product = $\dot{W}_{rev}$ $\dot{i} = \dot{W}_{calc} - \dot{W}_{rev} , \eta_{II} = \frac{\dot{W}_{rev}}{\dot{W}_{calc}}$	Condensate Pump	$\dot{W}_{isen} = \dot{m}_{17} \cdot h_{17,isen} - \dot{m}_{16} \cdot h_{16}$ $\dot{W}_{calc} = \dot{m}_{17} \cdot h_{17} - \dot{m}_{16} \cdot h_{16}$ $\dot{W}_{rev} = \dot{E}x_{17} - \dot{E}x_{16}$
Feed-water Booster Pump	$\dot{W}_{isen} = \dot{m}_{22} \cdot h_{22,isen} - \dot{m}_{21} \cdot h_{21}$ $\dot{W}_{calc} = \dot{m}_{22} \cdot h_{22} - \dot{m}_{21} \cdot h_{21}$ $\dot{W}_{rev} = \dot{E}x_{22} - \dot{E}x_{21}$	Feed-water Main Pump	$\dot{W}_{isen} = \dot{m}_{28} \cdot h_{28,isen} + \dot{m}_{27} \cdot h_{27,isen} - \dot{m}_{26} \cdot h_{26}$ $\dot{W}_{calc} = \dot{m}_{28} \cdot h_{28} + \dot{m}_{27} \cdot h_{27} - \dot{m}_{26} \cdot h_{26}$ $\dot{W}_{rev} = \dot{E}x_{28} + \dot{E}x_{27} - \dot{E}x_{26}$
Heater 1	$Fuel = \dot{E}x_1 - \dot{E}x_{40}$ $Product = \dot{E}x_{out} - \dot{E}x_{18}$ $\dot{i} = \dot{E}x_{18} + \dot{E}x_1 - (\dot{E}x_{out} + \dot{E}x_{40})$ $\eta_{II} = \frac{\dot{E}x_{out} - \dot{E}x_{18}}{\dot{E}x_1 - \dot{E}x_{40}}$	Heater2	$Fuel = \dot{E}x_2 + \dot{E}x_{38} - \dot{E}x_{39}$ $Product = \dot{E}x_{19} - \dot{E}x_{out}$ $\dot{i} = \dot{E}x_2 + \dot{E}x_{out} + \dot{E}x_{38} - (\dot{E}x_{39} + \dot{E}x_{19})$ $\eta_{II} = \frac{\dot{E}x_{19} - \dot{E}x_{out}}{\dot{E}x_2 + \dot{E}x_{38} - \dot{E}x_{39}}$
Heater3	$Fuel = \dot{E}x_3 - \dot{E}x_{38}$ $Product = \dot{E}x_{20} - \dot{E}x_{19}$ $\dot{i} = \dot{E}x_{19} + \dot{E}x_3 - (\dot{E}x_{20} + \dot{E}x_{38})$ $\eta_{II} = \frac{\dot{E}x_{20} - \dot{E}x_{19}}{\dot{E}x_3 - \dot{E}x_{38}}$	Deaerator	$Fuel = \dot{E}x_4 + \dot{E}x_{37} + \sum_{PR} \dot{E}x$ $Product = \dot{E}x_{21} - \dot{E}x_{20}$ $\dot{i} = \dot{E}x_4 + \dot{E}x_{20} + \dot{E}x_{37} + \sum_{PR} \dot{E}x - \dot{E}x_{21}$ $\eta_{II} = \frac{\dot{E}x_{21} - \dot{E}x_{20}}{\dot{E}x_4 + \dot{E}x_{37} + \sum_{PR} \dot{E}x}$
Heater5	$Fuel = \dot{E}x_5 + \dot{E}x_{36} - \dot{E}x_{37}$ $Product = \dot{E}x_{23} - \dot{E}x_{22}$ $\dot{i} = \dot{E}x_5 + \dot{E}x_{22} + \dot{E}x_{36} - (\dot{E}x_{37} + \dot{E}x_{23})$ $\eta_{II} = \frac{\dot{E}x_{23} - \dot{E}x_{22}}{\dot{E}x_5 + \dot{E}x_{36} - \dot{E}x_{37}}$	Heater6	$Fuel = \dot{E}x_6 + \dot{E}x_{35} - \dot{E}x_{36}$ $Product = \dot{E}x_{24} - \dot{E}x_{23}$ $\dot{i} = \dot{E}x_6 + \dot{E}x_{23} + \dot{E}x_{35} - (\dot{E}x_{36} + \dot{E}x_{24})$ $\eta_{II} = \frac{\dot{E}x_{24} - \dot{E}x_{23}}{\dot{E}x_6 + \dot{E}x_{35} - \dot{E}x_{36}}$
Heater7	$Fuel = \dot{E}x_7 + \dot{E}x_{34} - \dot{E}x_{35}$ $Product = \dot{E}x_{32} - \dot{E}x_{31}$ $\dot{i} = \dot{E}x_7 + \dot{E}x_{31} + \dot{E}x_{34} - (\dot{E}x_{35} + \dot{E}x_{32})$ $\eta_{II} = \frac{\dot{E}x_{32} - \dot{E}x_{31}}{\dot{E}x_7 + \dot{E}x_{34} - \dot{E}x_{35}}$	Heater8	$Fuel = \dot{E}x_8 - \dot{E}x_{34}$ $Product = \dot{E}x_{33} - \dot{E}x_{32}$ $\dot{i} = \dot{E}x_8 + \dot{E}x_{32} - (\dot{E}x_{34} + \dot{E}x_{33})$ $\eta_{II} = \frac{\dot{E}x_{33} - \dot{E}x_{32}}{\dot{E}x_8 - \dot{E}x_{34}}$
Boiler	$Fuel = \dot{W}_{B,i} + \dot{E}x_{fuel} + \dot{E}x_{air} - \dot{E}x_{AH,eg}$ $Product = \dot{E}x_9 + \dot{E}x_{12} - (\dot{E}x_{33} + \dot{E}x_{11} + \dot{E}x_{27} + \dot{E}x_{29})$ $\dot{i} = \dot{W}_{B,i} + \dot{E}x_{fuel} + \dot{E}x_{air} + \dot{E}x_{33} + \dot{E}x_{11} + \dot{E}x_{27} + \dot{E}x_{29} - (\dot{E}x_9 + \dot{E}x_{12} + \dot{E}x_{AH,eg})$ $\eta_{II} = \frac{\dot{E}x_9 + \dot{E}x_{12} - (\dot{E}x_{33} + \dot{E}x_{11} + \dot{E}x_{27} + \dot{E}x_{29})}{\dot{W}_{B,i} + \dot{E}x_{fuel} + \dot{E}x_{air} - \dot{E}x_{AH,eg}}$	Condenser	$\dot{Q}_{loss} = \dot{m}_{15}(h_{15} - h_{16}) + \dot{m}_{37b}(h_{37b} - h_{16}) + \dot{m}_{39}(h_{39} - h_{16}) + \dot{m}_{40}(h_{40} - h_{16})$ $\dot{i} = \dot{E}x_{15} + \dot{E}x_{37b} + \dot{E}x_{39} + \dot{E}x_{40} + \dot{E}x_{CCW,i} + \dot{W}_{CP} - (\dot{E}x_{17} + \dot{E}x_{CCW,e})$
Power Plant	$\dot{W}_{net} = \dot{W}_{Turbines} - \sum \dot{W}_{cons}$ $\eta_{I,Overall} = \frac{\dot{W}_{net}}{\dot{m}_{fuel} \cdot CV}$ $\eta_{II,Overall} = 1 - \sum \frac{\dot{i}_i}{\dot{E}x_{fuel}}$		

# International Journal of Innovative Research in Science, Engineering and Technology

(An ISO 3297: 2007 Certified Organization)

Website: [www.ijirset.com](http://www.ijirset.com)

Vol. 6, Issue 2, February 2017

Where,

CV	Calorific value	kJ/kg	$\dot{Q}_{loss}$	Heat rate loss in the condenser	kW
$\dot{E}_x$	Exergy rate	kW	$\dot{W}$	Power	kW
$\dot{E}_{x_{AH, eg}}$	Exergy rate of air heater exit gases	kW	$\dot{W}_{Calc}$	Mechanical calculated power without coupling and electrical losses in generator	kW
h	Specific enthalpy	kJ/kg	$\dot{W}_{cons}$	Consumed power by machines such as pumps, fans and compressors	kW
i	Exergy destruction rate (Irreversibility)	kW	$\eta_I$	Efficiency according to first law of thermodynamics (Energy efficiency)	
m	Mass flow rate	kg/s, t/h	$\eta_{II}$	Efficiency according to second law of thermodynamics (Exergy efficiency)	

## IV. RESULTS AND DISCUSSIONS

We supplied the operating parameters of the power plant at 50% load (175 MW) in 2011 to the EEA. It summarises the power plant energy and exergy results presenting them in Figure 2. It shows the exergy efficiency and destruction of the power plant. Moreover, it presents the generated power, consumed power and net generated power of the power plant. Furthermore, it shows the thermal efficiency of the power plant based on the lower and higher heating values.

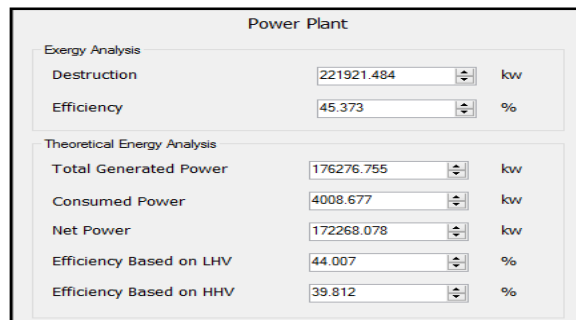

Fig. 2: Energy and exergy summary of the power plant.

Figure 3 provides the energetic and exergetic loss, destruction, of the main systems. It reveals that despite the condenser is the main reason for energy loss in the power plant, its exergy destruction is insignificant. Moreover, it shows that the boiler is the main source of exergy destruction despite its low energy loss.

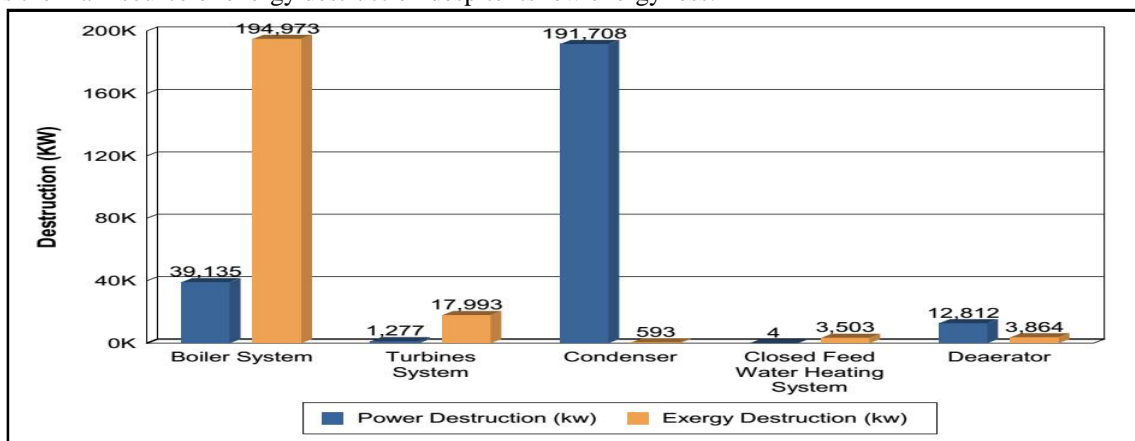

Fig. 3: Power and exergy destruction.

## International Journal of Innovative Research in Science, Engineering and Technology

(An ISO 3297: 2007 Certified Organization)

Website: [www.ijirset.com](http://www.ijirset.com)

Vol. 6, Issue 2, February 2017

EEA presents the exergy analyses of the main systems in the power plant in Figure 4. It shows that the turbine system has the highest exergetic efficiency of the power plant. Moreover, it reveals that the boiler system has the lowest exergetic efficiency of the power plant.

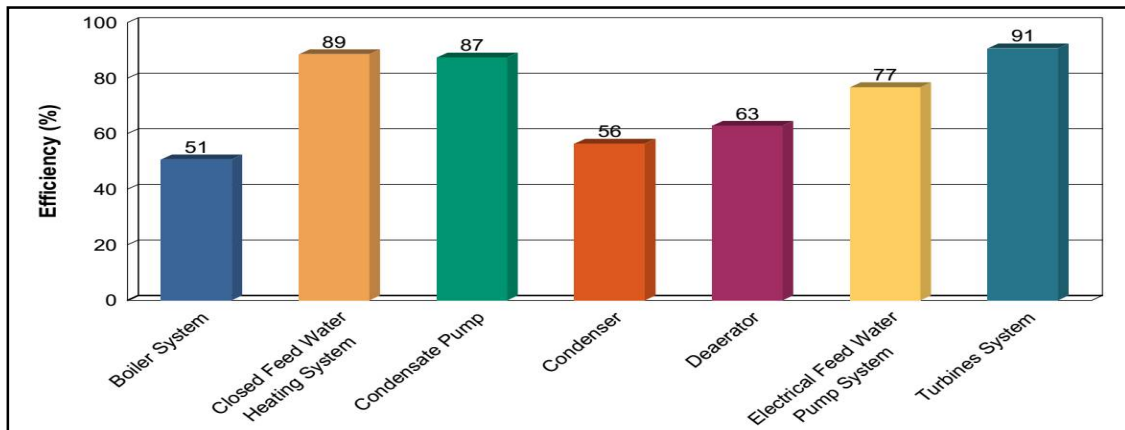

Fig. 4: Exergetic efficiency of main systems.

The pie chart shown in Figure 5 shows that 195 MW of exergy destroyed in the boiler making it the major system responsible for the exergetic destruction in the power plant. Moreover, it shows that the exergetic destruction of the turbine system is significant compared to other systems in spite of its high efficiency.

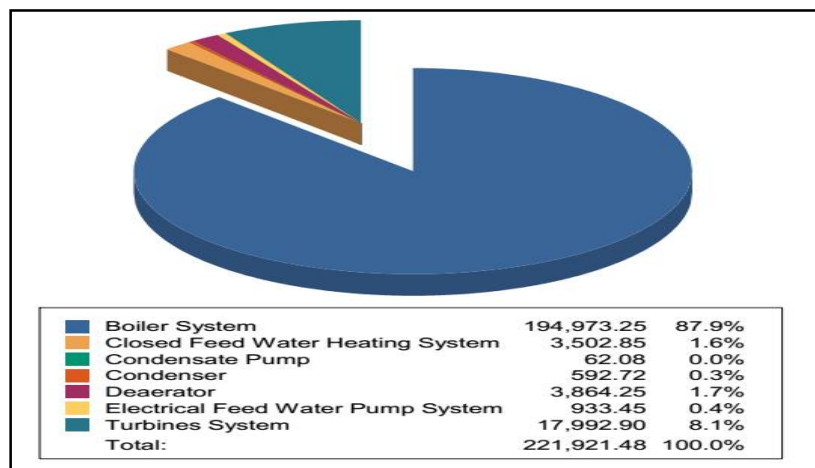

Fig. 5: Exergy destruction pie chart of main systems.

The previous results present strong evidence that the boiler is the main system responsible for exergetic destruction in the power plant. So, EEA presents the boiler results in detail. Figure 6 (a) shows the gross and fuel energy efficiencies of the boiler. Furthermore, it presents the exergetic efficiency of the boiler. Moreover, Figure 6 (b) present the generated fuel model, equivalent to the hydrocarbon fuel mixture, and its properties.

## International Journal of Innovative Research in Science, Engineering and Technology

(An ISO 3297: 2007 Certified Organization)

Website: [www.ijirset.com](http://www.ijirset.com)

Vol. 6, Issue 2, February 2017

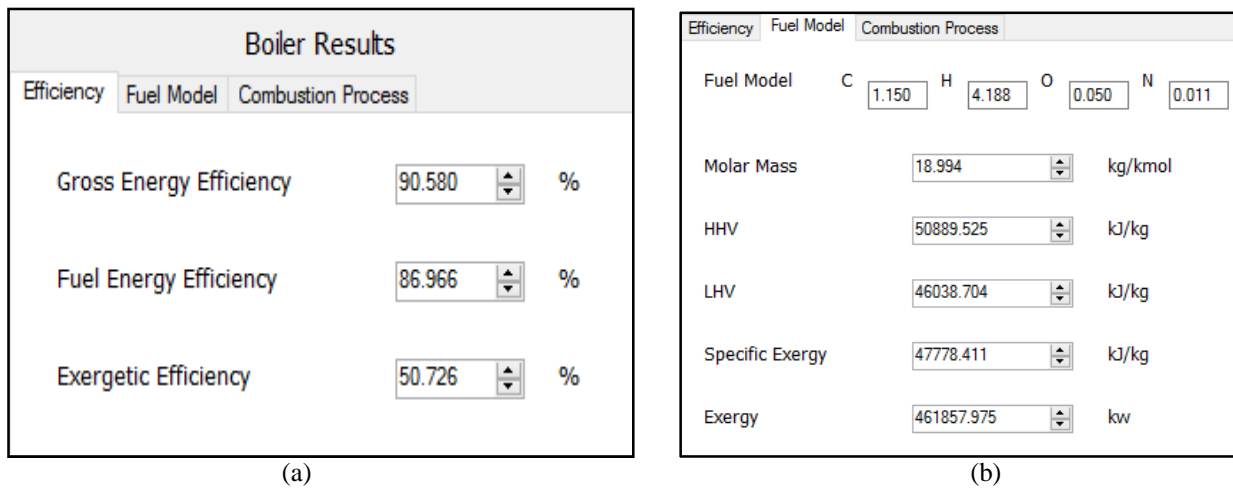

Fig. 6: Boiler efficiency.

In order to compare the exergetic efficiencies of the boiler processes and subsystems, EEA generates a bar chart as shown in Figure 7. It shows that the air preheater has the highest exergetic efficiency in the boiler. It reveals that the boiling and superheating process has the lowest exergetic efficiency in the boiler.

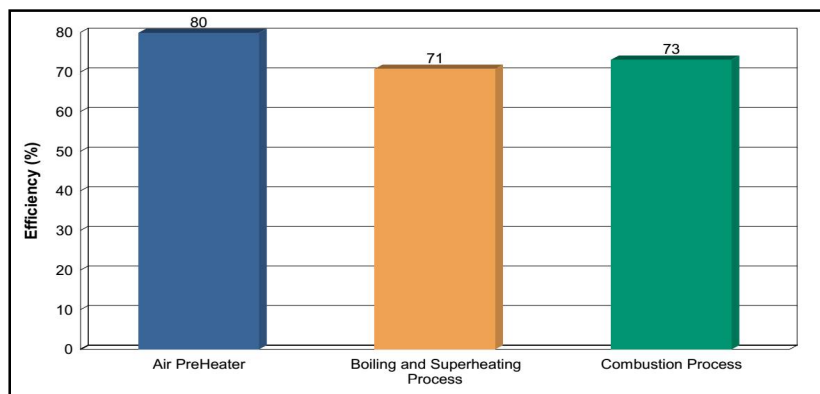

Fig. 7: Boiler exergetic efficiency.

The pie chart illustrated in Figure 8 shows that more than 56% of the boiler exergy destruction is due to the combustion process. Moreover, it shows that 42% of the boiler exergy destruction is due to the boiling and superheating process. Finally, it shows that the exergetic destruction occurs in the air preheater is insignificant.

## International Journal of Innovative Research in Science, Engineering and Technology

(An ISO 3297: 2007 Certified Organization)

Website: [www.ijirset.com](http://www.ijirset.com)

Vol. 6, Issue 2, February 2017

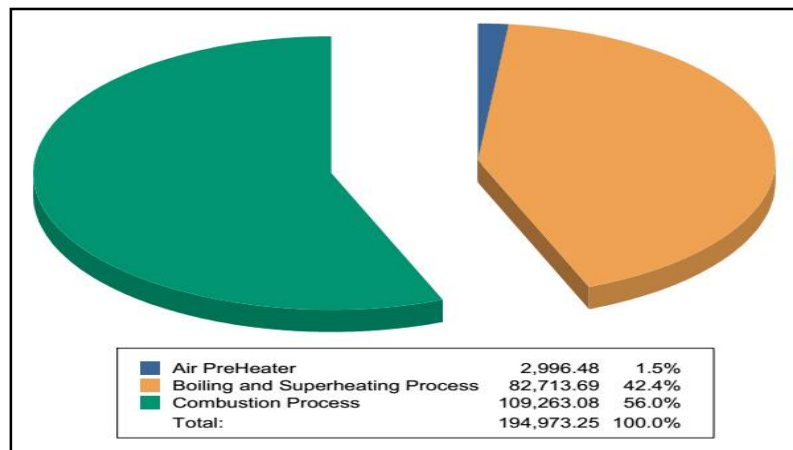

Fig. 8: Boiler exergy destruction pie chart.

We made a comparison between the power plant operating parameters at half load in Figure 9. It illustrates the exergy destruction of the boiler processes which recorded in different years. It shows that, in 2013, there is a dramatic increment in the fuel flow rate, the exergetic destruction of the combustion process and boiling and superheating processes.

As a result of using the backup fuel (Oil number 6) instead of the main fuel (Natural gas) for a long time, many problems occur in the boiler such as:

- Corrosion occurs in the burner impeller and gas spuds. Some burners are totally damaged.
- Ashes and deposits from the fuel oil combustion process fouled the heating surface of the boiler tubes.
- Ashes and deposits clogged the spaces between the tubes as presented.
- Some tubes displaced from its original locations clogging the product gases pass.

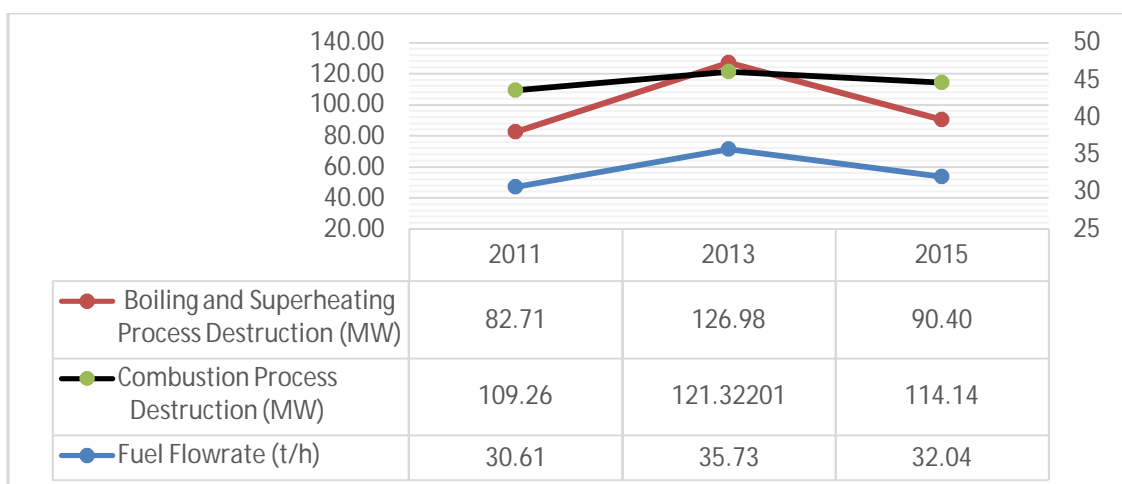

Fig. 9: Exergy destruction in boiler processes.

Due to these problems, the fuel consumption increased to overcome the decrement of the heat absorption through the tubes which increased the combustion process destruction. Moreover, the exergetic destruction in the boiling and superheating processes increased dramatically which led to a gigantic destruction in the boiler system. As a result of the destruction increment, the thermal and exergetic efficiencies of the boiler decreased as shown in Figure 10. It illustrates



# International Journal of Innovative Research in Science, Engineering and Technology

(An ISO 3297: 2007 Certified Organization)

Website: [www.ijirset.com](http://www.ijirset.com)

Vol. 6, Issue 2, February 2017

the gross energy, fuel energy and exergetic efficiency of the boiler. Finally, the overall power plant exergetic efficiency decreased as shown in Figure 11.

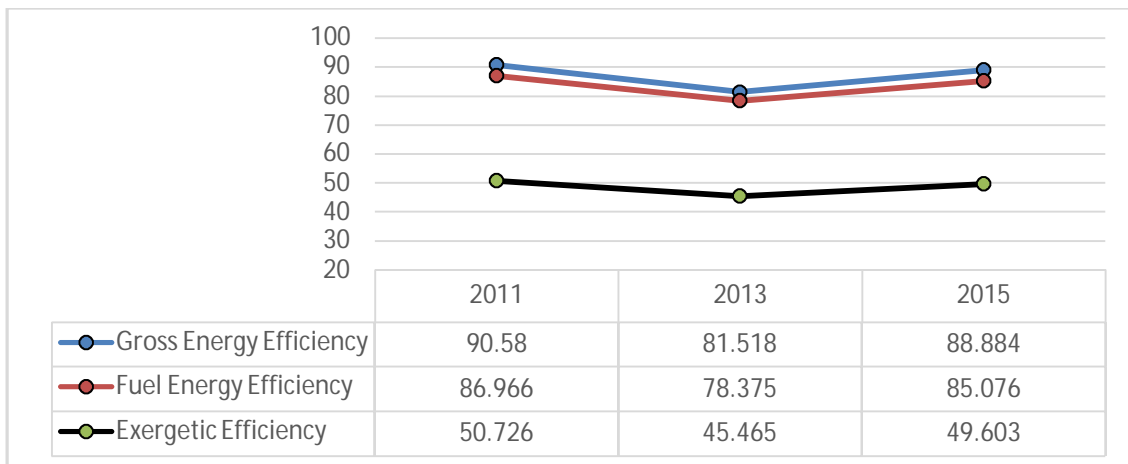

Fig. 10: Boiler efficiencies.

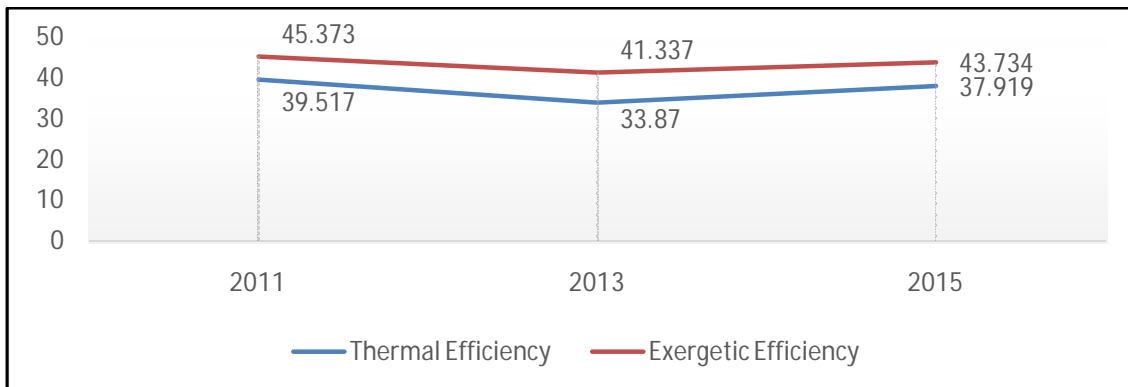

Fig. 11: Power plant efficiency in different years.

In 2015, the unit was shut down for a major overhaul. Damaged parts in the burners are replaced. Furthermore, chemical cleaning of the tubes has been done removing much of the deposits. Finally, some tubes are displaced close to its original positions.

As a result of these procedures, the exergetic destruction of the combustion process and the boiling and superheating process decreased in 2015 as shown in Figure 9. This decrement led to a significant decrement in the boiler exergy destruction which increased the thermal and exergetic efficiencies of the boiler as shown in Figure 10. Finally, the overall power plant thermal and exergetic efficiencies increased as shown in Figure 11.

## V. CONCLUSION AND RECOMMENDATIONS

The first author proposed and built a computer program (EEA). We used it to evaluate the performance of the Cairo West Thermal Power Plant of different operating parameters. It showed that the condenser is the main system responsible for power (energy) loss in the power plant and the boiler comes in the second place. Furthermore, it presented the turbine system as the highest exergetic efficiency system and the boiler system as the lowest exergetic

# International Journal of Innovative Research in Science, Engineering and Technology

(An ISO 3297: 2007 Certified Organization)

Website: [www.ijirset.com](http://www.ijirset.com)

Vol. 6, Issue 2, February 2017

efficiency system in the power plant. Moreover, EEA provided a strong evidence that the boiler is the main source of exergy destruction with 195 MW destruction due to combustion, boiling and superheating processes. Finally, it showed that, in 2013, the exergetic destruction in the boiling and superheating processes increased dramatically, which led to a gigantic destruction in the boiler system and the power plant.

In order to decrease the exergetic destruction in the boiler and increase the boiler and the power plant efficiency, we recommend to:

1. Replace the burners' impellers with new ones with greater spaces to prevent ashes and deposits from clogging these spaces.
2. Supply air pipe to the gas spuds to cool it down, when using fuel oil in the combustion process.
3. Operate the upper row of burners with natural gas in the case of mixed fire operation. Therefore, the higher flame temperature of the natural gas burners will achieve a complete combustion of the unburned fuel oil products.
4. Make a chemical test for the fuel oil additive dosing substance to ensure that it is suitable for the fuel oil chemical composition.

In addition to these modifications, we need to upgrade the EEA to cover more systems such as; Gas Turbine system, Combined Power Plants, Geo Thermal Power Plants and Solar Power Plants. Furthermore, it is important to cover more fuels such as; Fuel oil number 6 (Mazout). Moreover, further thermodynamic analyses of the Cairo West Thermal Power Plant should be performed in these cases:

- Using fuel oil as the main fuel
- Using mixed firing

Finally, it is important to create a power plant designer, which allows users to supply the target electric load generation required and it will generate a power plant design and present the plant components with their technical specifications.

## REFERENCES

- [1] U. States. and E. I. Administration., "Official energy statistics from the U.S. government", Energy Information Administration, Washington, DC.
- [2] Sato N., "Chemical Energy and Exergy: An Introduction to Chemical Thermodynamics for Engineers", Elsevier Science & Technology Books, 2004.
- [3] Dincer, I., Rosen, M.A., "Exergy, Energy, Environment And Sustainable Development", 2nd ed. Elsevier, 2013.
- [4] Moran, M. J., "Fundamentals of Exergy Analysis and Exergy-Aided Thermal Systems Design in Thermodynamic Optimization of Complex Energy Systems, A. Bejan and E. Mamut", Springer, pp. 73–92, 1999.
- [5] Aljundi, I. H., "Energy and exergy analysis of a steam power plant in Jordan", Applied Thermal Engineering, vol. 29, no. 2–3, pp. 324–328, Feb. 2009.
- [6] Ameri, M., Ahmadi, P., and Hamidi, A., "Energy, exergy and exergoeconomic analysis of a steam power plant: A case study", International Journal of Energy Research, vol. 33, no. 5, pp. 499–512, Apr. 2009.
- [7] Afifi, I. H., "Theoretical Analysis and Practical Application of Exergy for a Co-Generation Plant at Different Operating Conditions", Cairo University, 2002.
- [8] Altayib, K., "Energy, Exergy and Exergoeconomic Analyses of Gas-Turbine Based Systems", University of Ontario Institute of Technology, 2011.
- [9] Ameri, M., Ahmadi, P., and Khanmohammadi, S., "Exergy Analysis of a 420 MW Combined Cycle Power Plant", International Journal of Energy Research, vol. 32, no. 2, pp. 175–183, Feb. 2008.
- [10] Ahmadi, G. R., and Toghraie, D., "Energy and Exergy Analysis of Montazeri Steam Power Plant in Iran", Renewable and Sustainable Energy Reviews, vol. 56, pp. 454–463, Apr. 2016.
- [11] Singh, S., et al., "Exergy Analysis of Steam Power Plant for Different Grades of Coal", National Institute Of Technology, Raipur, 2012.
- [12] Ahmadi, P., and Dincer, I., "Thermodynamic and Exergoenvironmental Analyses, and Multi-Objective Optimization of a Gas Turbine Power Plant", Applied Thermal Engineering, vol. 31, no. 14–15, pp. 2529–2540, 2011.
- [13] Fungtamman, B., Pojwattana, P., and Jarumas, K., "A Computer Program for Energy and Availability Analyses of Thermal Power Plants", in International Conference on Energy and Environment, 1990.