

Performance Optimization of Pi Controller in Three Phase Shunt Hybrid Filter Using PSO

A.Selvanayakam¹, K.Sairanjith², A.C.Varishnee³, J.Priyadharshini⁴

Assistant Professor, Dept. of EEE, Sri Krishna College of Engineering & Technology, Coimbatore, Tamilnadu, India¹

PG Student [PED], Dept. of EEE, Sri Krishna College of Engineering & Technology, Coimbatore,
Tamilnadu, India^{2,3,4}

ABSTRACT : This paper attempts to tune the PI parameters in the implementation on shunt hybrid filter by using a meta heuristic optimising technique like PSO. Total Harmonic Distortion is taken as the objective parameters for the reduction of THD to be reduced. The PI tuning is done using both Zeiglers method and PSO is carried out and compared for the optimized THD value for a Shunt Hybrid filter. Zeigler method is basically a traditional method of PI tuning and PSO is an optimization method that would increase the accuracy in tuning. The optimization method used proved to be a better method in the optimization of the PI parameters for the reduction of THD. This paper has also attempted in linking PI value for the THD reduction problem. simulation is carried out based on MATLAB and the results are carried out and compared for the THD and voltage ripple.

KEYWORDS : Shunt Hybrid Filter, Particle Swarm Optimization, Total Harmonic Distortion.

I. INTRODUCTION

In power systems harmonic compensation has become increasingly important due to the widespread use of a adjustable speed drives, arc furnace, switched-mode power supply, uninterruptible power supply. Harmonics produce unwanted disturbance to the communication network and also increase the losses. There were a number of mitigation solutions that were being proposed. Active power line conditioner has been always the natural choice to compensate for harmonics due to the recent technological advancement of switching devices and availability of cheaper controlling devices. Many harmonic extraction techniques are available, the proposed techniques include traditional d-q and p-q theory based approaches and application of adaptive filters, wavelet, genetic algorithm, artificial neural network for the quick estimation of the compensating current. Certain analysis have revealed that total harmonic distortion (THD) in the supply currents cannot be brought down below 5% to satisfy the IEEE-519 standard. This is due to the presence of disturbances in the supply currents. The drawbacks can be eliminated by using the nonlinear control theory, constantly without exaggerating computational and implementation complexities. The stabilization of the dc-link voltage dynamics is addressed, along with the fulfillment of the harmonic load current compensation objective. The current loop dynamics in the synchronous d-q frame are controlled using multiple-input multiple-output optimal control based on the predictive control approach. The nonlinear control strategy does not require online optimization and overcome the aforementioned difficulties by ensuring fast current tracking, current loop stability and compensation robustness under non ideal load or supply conditions. The shunt active filter requires high dc-link voltage in order to effectively compensate higher order harmonics. Also a series active filter requires a transformer that is capable to withstand full load current in order to balance for voltage distortion. Even the costs of such filters are relatively high for large scale system and are to utilize in high-voltage grids. The compensating performance is better in the harmonic current source load type. The performance of the Zeiglers Nichols method and PSO implementation on the filters is observed and inferred in this paper. The PSO based implementation of the three phase hybrid filter is improved in terms of optimizing the parameters of PI controller. By implementation of these would decrease the time required for the calculation occurring in the Evolutionary Programming Techniques. The P-Q theory based implementation is taken up and trained and checked for the output. Also the PSO based optimization is implemented and compared for the parameters like the

execution time and the error tolerance obtained after the iterations. Matlab based simulation is carried out and results are tabulated and compared.

II. SHUNT HYBRID FILTER TOPOLOGY

The three phase shunt hybrid filter is connected in between the source and the non linear load which is three phase diode rectifier. The hybrid filter acts as controlled current source connected in parallel with nonlinear load. It consists of a full bridge voltage source Pulse Width Modulation (PWM) inverter, high frequency inductors and DC side capacitors that are required to shape the compensator currents.

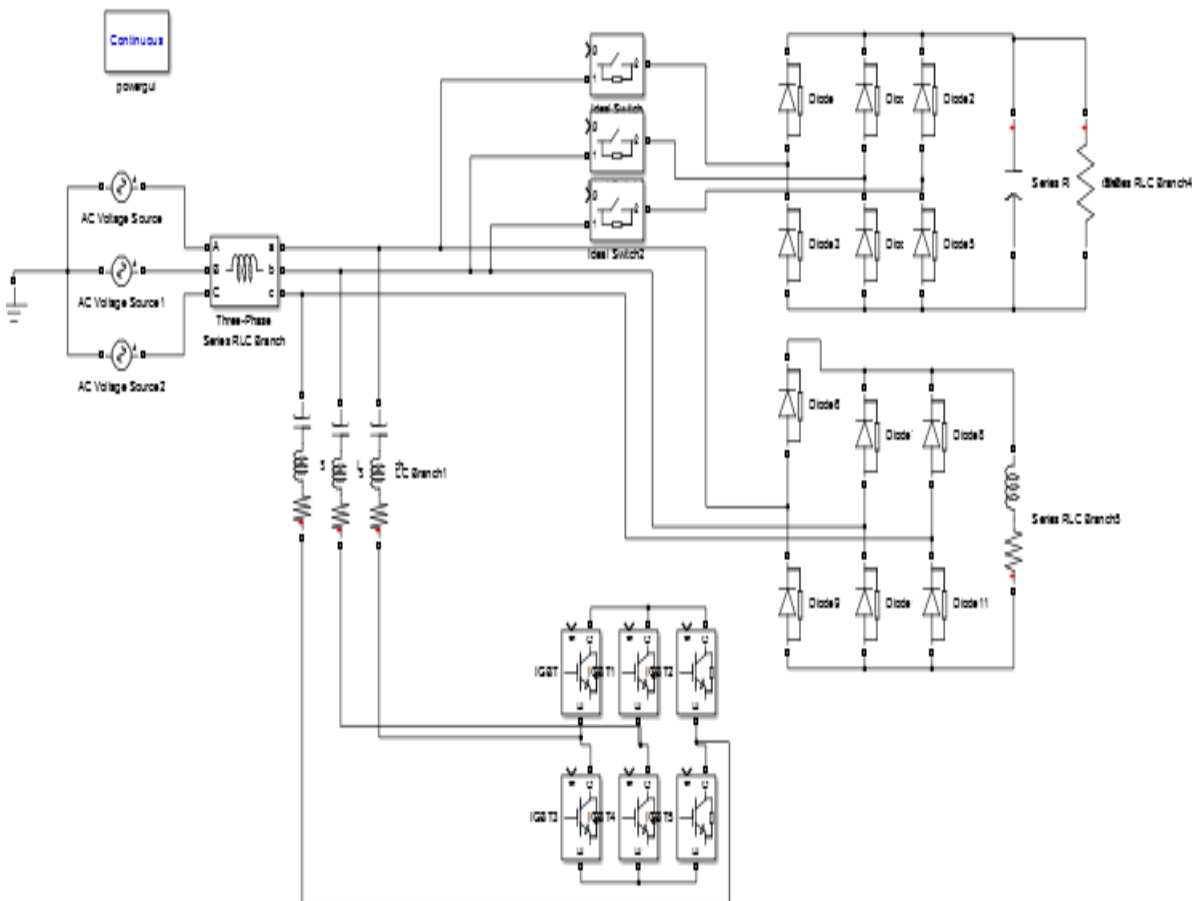

Fig 1 : Basic circuit of Shunt Hybrid Filter

III. APPROACHES WITH ZEIGLER NICHOLS METHOD, PSO

The performance of different active filtering techniques in Shunt Hybrid Power Filter using the intelligent techniques which is supported by PSO for fast convergence. The PI tuning using Zeiglers Nichols method and Particle Swarm Optimization is carried out and compared for the optimized THD value for a Shunt Hybrid Filter. The objective function for PSO is to minimize the mean square error.

ZEIGLER NICHOLS METHOD

The Zeigler Nichols tuning method is a heuristic method of tuning the PI controller. Its basically performed by setting the integral value and derivative gains to zero. The proportional gain is then increased from zero until it reaches the ultimate gain, at which the output of the control loop oscillates with constant amplitude. For tuning processes that cannot run in open-loop systems as Zeigler-Nichlos closed-loop tuning method is limited. Determining the definitive gain value is accomplished by finding the value of the proportional only gain that causes the control loop to oscillate indefinitely at steady state. This states that the gains from the Intergral and Derivative controller are set to zero so that the influence of P can be determined. Another important value associated with this proportional only control tuning method is the ultimate period. The ultimate period is the time required to complete one full oscillation while the system is at steady state. These two parameters, ultimate gain value and ultimate period of oscillation, are used to find the loop-tuning constants of the PI controller. Having the ultimate gain and frequency (k_u and P_u) and using Table 1, the controller parameters can be obtained.

Controller	Kc	I	D
P	$0.5K_{cu}$	-	-
PI	$0.45K_{cu}$	$P_u/1.2$	-
PID	$0.6K_{cu}$	$P_u/2$	$P_u/8$

Table 1-Controller parameters for closed loop Ziegler-Nichols method

The tuning rules works well when there is an analog controller, a system that is linear, monastic and sluggish and a response that is dominated by a single pole exponential “lag” or something that acts a lot like one.

Ziegler-Nichols closed loop PI control

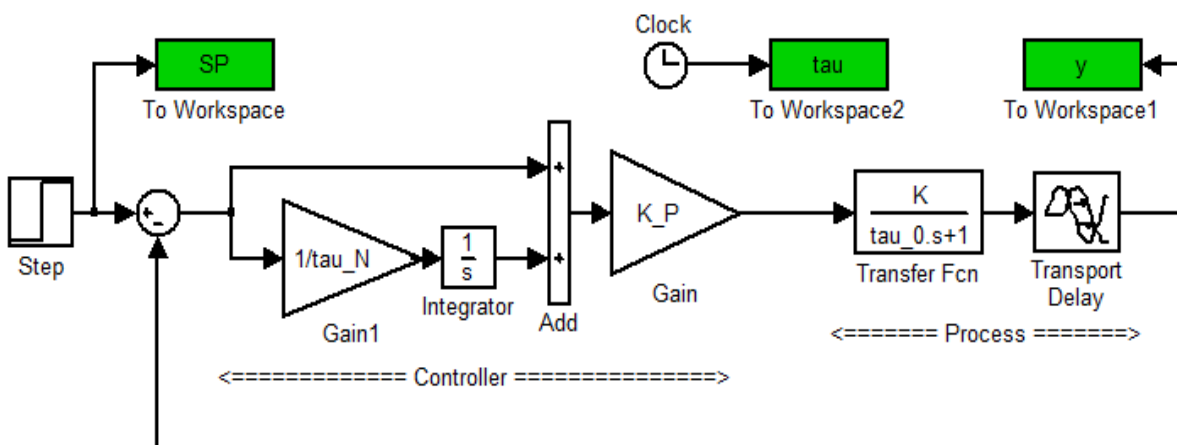

Fig2:ZEIGLER-NICHOLS CLOSED LOOP OF PI CONTROLLER

PARTICLE SWARM OPTIMIZATION

Particle Swarm Optimization is a population based stochastic optimization technique simulated by social behavior of fish schooling or bird flocking. This is used to solve the optimization problems. In PSO, each solution is a

“bird” in the search space described as “particle”. In common all particles have their fitness values which are evaluated by the fitness function to be optimized and have velocities which direct the flying of the particles. PSO is initialized with a group of random particles that are then searched for optima by updating generations.. There are a number of iterations that occur, in each iteration every particle is updated by following two “best” values. On considering the first iteration the first one is the best solution (fitness) it has achieved so far. This value is called P_{best} . Another “best” value that is tracked by the particle swarm optimizer is the best value, obtained so far by any particle in the population. This best value is a global best and called g_{best} . The i_{th} particle is represented as $X_i=(X_{i1},X_{i2},\dots,X_{id})$ in the d-dimensional space.

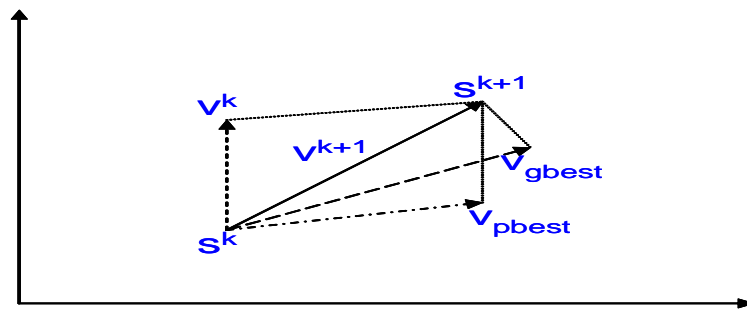

Fig 3 : Concept of modification of a searching point by PSO

IV. RESULT AND DISCUSSION

The problem of harmonic reduction has been analyzed. PI tuning using both Ziegler’s method and Particle Swarm Optimization method is carried out and compared for the optimized THD value for a Shunt Hybrid filter. The obtained results show that the harmonic current control is very important. The three phase shunt hybrid filter for the three phase circuit is simulated and the Total Harmonic Distortion measure verifies the reduction of harmonics to a very low level, when the Particle Swarm Optimization method is employed. The three phase Shunt Hybrid filter provides advantages such as improvement of supply current waveform, less harmonic distortion and its use in high power/ medium voltage with the lower maximum device rating.

Simulation Results

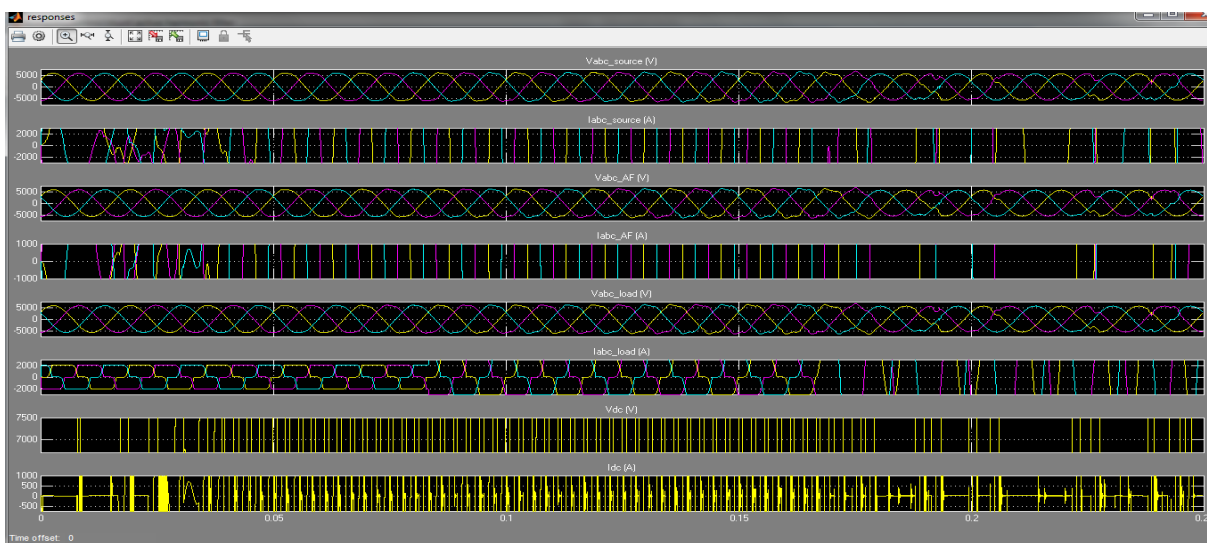

Fig 4: Waveform of Zeigler Nicholas Method

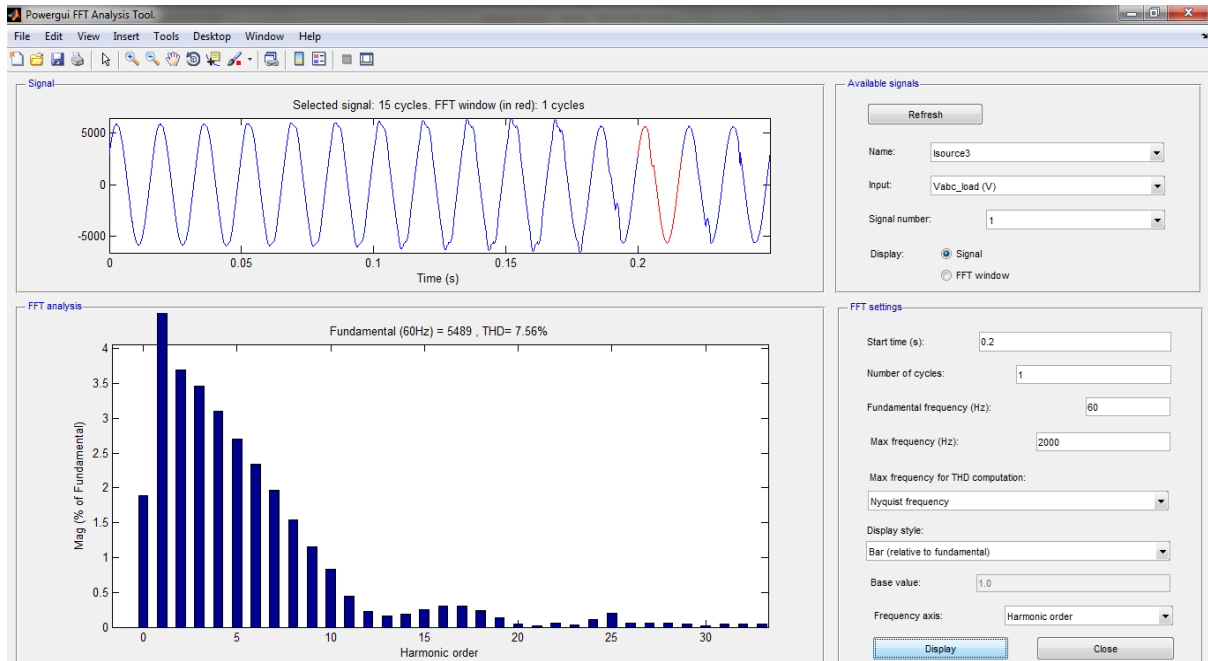

Fig 5: The THD content in the source voltage. The THD in source voltage is 7.56% in Ziegler Nichols method.

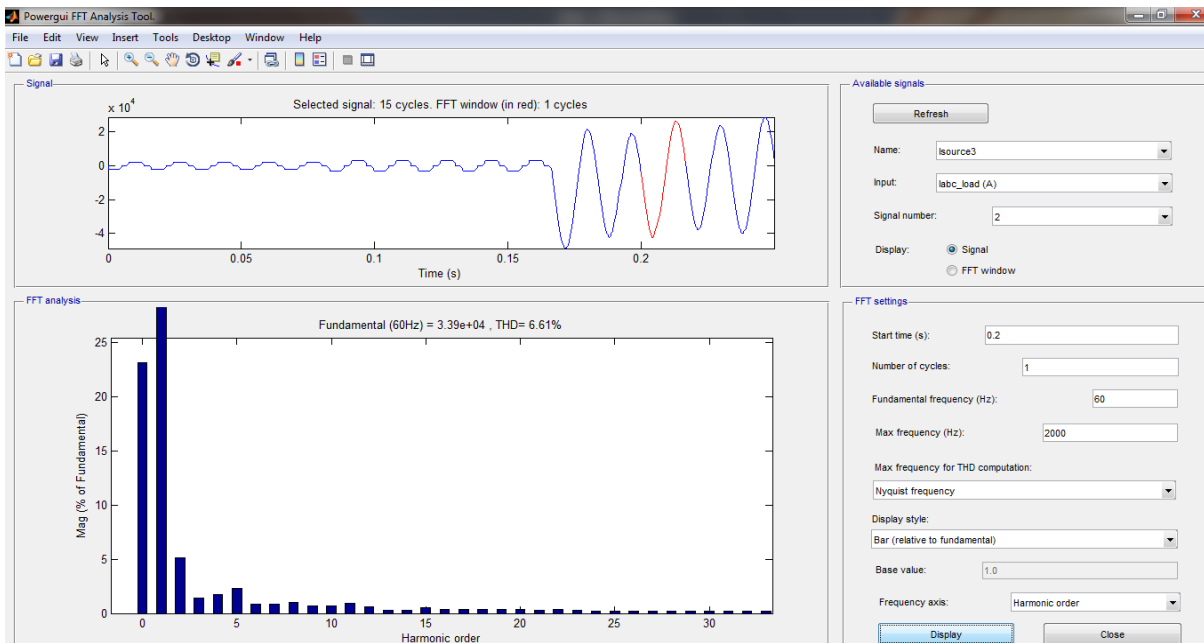

Fig 6 : the THD content in load source. The THD in load current is 6.61% using Ziegler Nichols method.

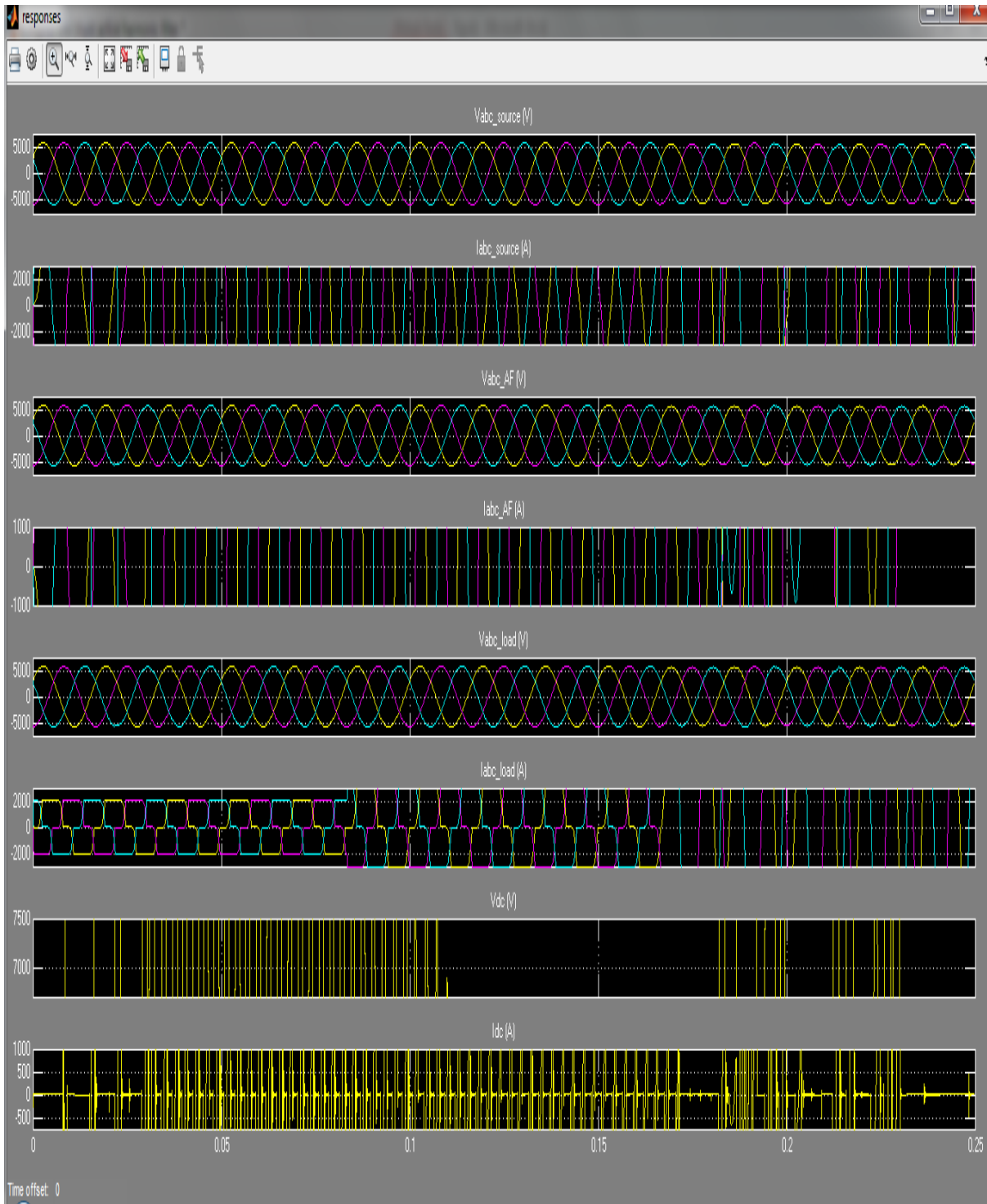

Fig 7: Waveform for PSO method

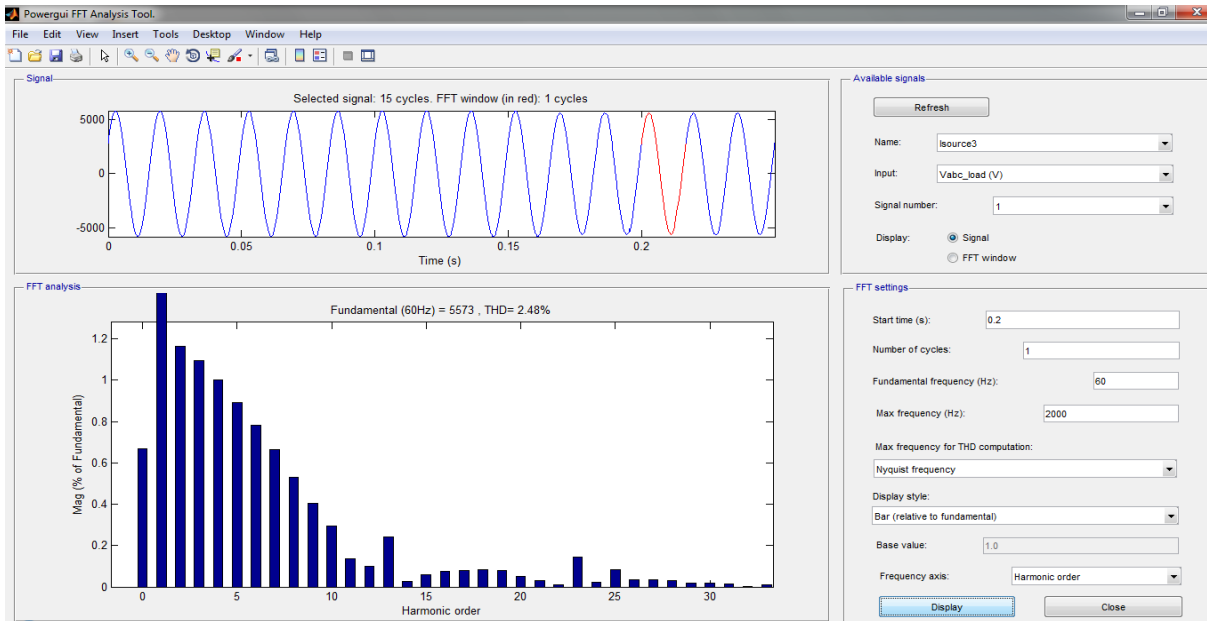

Fig 8 : The THD content in voltage source. The THD voltage source is 2.48% using PSO (Particle Swarm Optimization) method.

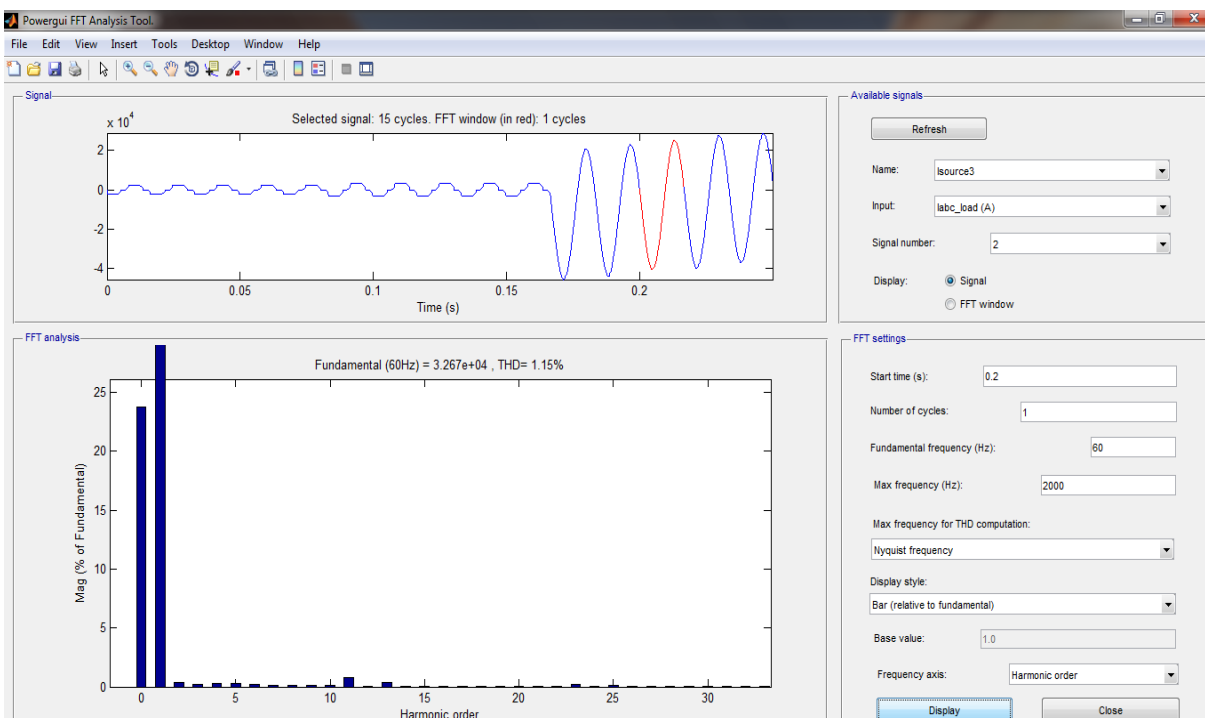

Fig 9 : The THD content in load current. The THD load current is 1.15% using PSO (Particle Swarm Optimization) method

TOTAL HARMONIC DISTORTION RESULTS

METHODS USED	VOLTAGE THD	CURRENT THD
ZN METHOD	7.56 %	6.61 %
PSO METHOD	2.48 %	1.15 %

In Ziegler’s Nichols method the Total Harmonic Distortion value is 6.61% for LOAD CURRENT by using Particle Swarm Optimization method the Total Harmonic Distortion value has been comparatively reduced to 1.15% for LOAD CURRENT. In Ziegler’s Nichols method the Total Harmonic Distortion value is 7.56% for SOURCE VOLTAGE by using Particle Swarm Optimization method the Total Harmonic Distortion value has been comparatively reduced to 2.48% for SOURCE VOLTAGE. Harmonics degrades the performance of power system. The harmonics flowing in the distribution network downgrade the quality of the electrical power supply. There can have several negative effects on the operation of the power system. Increased losses on the distribution system due to increase in the effective rms current. Over-load in neutral conductors due to cumulative increase in the third harmonics created by the single phase loads. Overloads vibration and premature ageing of the generators, transformers and motors as well as increase in the noise level. Overloads and premature ageing of the power factor correction capacitors. Distortion of the supply voltage that can disturb the operation of the sensitive loads. Disturbances in the communication networks and telephone lines. Resonance between the supply inductance and capacitance of the power factor correction capacitors. The above disadvantages can be eliminated by reducing the harmonics in the distribution system.

REFERENCES

[1] B. Singh, K. Al-Haddad, and A. Chandra, “A review of active power filters for power quality improvements,” IEEE Trans. Ind. Electron., vol. 46, no. 5, pp. 960–971, Oct. 1999.

[2] S. Bhattacharya, T. M. Frank, D. M. Divan, and B. Banerjee, “Active filter system implementation,” IEEE Ind. Appl. Mag., vol. 4, no. 5, pp. 47–63, Sep./Oct. 1998.

[3] H. Akagi, Y. Kanazawa, and A. Nabae, “Instantaneous reactive power compensators comprising switching devices without energy storage components,” IEEE Trans. Ind. Appl., vol. IA-20, no. 3, pp. 625–630, May 1984.

[4] F. Z. Peng, G.W. Ott, Jr., and D. J. Adams, “Harmonic and reactive power compensation based on the generalized instantaneous reactive power theory for three phase four wire system,” IEEE Trans. Power Electron., vol. 13, no. 6, pp. 1174–1181, Nov. 1998.

[5] R. S. Herrera and P. Salmeron, “Instantaneous reactive power theory: A reference in the nonlinear loads compensation,” IEEE Trans. Ind. Electron., vol. 56, no. 6, pp. 2015–2022, Jun. 2009.

[6] H. Karimi, M. Karimi-Ghartemani, and M. R. Iravani, “An adaptive filter for synchronous extraction of harmonics and distortions,” IEEE Trans. Power Del., vol. 18, no. 4, pp. 1350–1356, Oct. 2003.

[7] M. Forghani and S. Afsharnia, “Online wavelet transform based control strategy for UPQC control system,” IEEE Trans. Power Del., vol. 22, no. 1, pp. 481–491, Jan. 2007.

[8] A. Bhattacharya, C. Chakraborty, and S. Bhattacharya, “Current compensation in shunt type active power filters,” IEEE Ind. Electron. Mag., vol. 3, no. 3, pp. 38–49, Sep. 2009.

[9] A. Hamadi, S. Rahmani, and K. Al-Haddad, “A hybrid passive filter configuration for VAR control and harmonic compensation,” IEEE Trans. Ind. Electron., vol. 57, no. 7, pp. 2419–2434, Jul. 2010.

BIOGRAPHY



Selvanayakam.KC has obtained her Bachelor’s degree in Electrical and Electronics Engineering from P.A.College of Engineering and Technology and Master’s degree in Power Electronics and Drives from Sri Eshwar college of Engineering and currently working as an Assistant professor in Sri Krishna College of Engineering and Technology.

International Journal of Innovative Research in Science, Engineering and Technology

An ISO 3297: 2007 Certified Organization

Volume 6, Special Issue 14, August 2017

Two Days National Conference on Modernization in Engineering Science (NCMES 2K17)

23rd-24th March 2017

Organized by

Dept. of EEE, Sri Krishna College of Engineering & Technology, Coimbatore 641 008, Tamil Nadu, India



SAIRANJITH.K has obtained his Bachelor's degree in Electrical and Electronics Engineering from Dr Mahalingam College of Engineering and Technology and currently pursuing his Master's degree in Power Electronics and Drives from Sri Krishna College of Engineering and Technology.



Varishnee.A.C has obtained her Bachelor's degree in Electrical and Electronics Engineering from Avinashilingam Institute for Home Science and Higher Education For Women, University and currently pursuing her Master's degree in Power Electronics and Drives from Sri Krishna College of Engineering and Technology.



Priyadharshini.J has obtained her Bachelor's degree in Electrical and Electronics Engineering from Kumaraguru College of Technology and currently pursuing her Master's degree in Power Electronics and Drives from Sri Krishna College of Engineering and Technology.