

Coordination of Wind and Hydro Power Plant by Using Optimization Technique

P.Ranjithkumar¹, Saravana Prabaakar¹, M.Suganya², Niranjana B²

UG Scholar, Department of EEE, SKCET, Coimbatore-641008, Tamil Nadu, India¹

Assistant Professor, Department of EEE, SKCET, Coimbatore-641008, Tamil Nadu, India²

ABSTRACT: Wind power production experiences new challenges in operation of a power system due to its variability and uncertainty of the wind. The challenges can be met when we introduce a new storage facility which was already available in the existing power system. Existing hydro power plants with larger reservoirs or pumped storage hydro power plants can be used for compensation of this drawback. It is known that wind power is an uncertain energy source compared to hydroelectric generation which is easily scheduled. In this abstract, the method for coordinating wind power plant and hydroelectric power plant is carried out by using Fourier transform technique to measure and control the state of wind and hydro power plants. Hydroelectric generation is employed as a method of energy reserve and compensation for wind power fluctuation in order to provide efficient power supply to benefit wind providers. The Fourier technique, which is generally used for relation of periodic functions like sine and cosine waves, is used here for the purpose of co-ordination. In order to control the output of a hydropower plant according to the output of a wind power plant, the control systems are provided at each power plant which monitors the power output of respective power plant and the system uses Fourier technique to analyze the state flow. Hybrid simulation studies, which are based on MATLAB/Simulink/ Powersystem/Stateflow, are carried out to coordinate the continuous power supply system. It shows that system can be used for regulated energy flow at different wind conditions. Therefore, the suggested coordinated control method can ensure wind-hydro hybrid power system optimizing operation.

KEYWORDS: PMU-Phasor Measurement Unit, DFT- Discrete Fourier Transform, MATLAB, optimization, Wind power, Hydro power.

I. INTRODUCTION

Wind, solar, hydro and other forms of renewable energies could be the fastest growing power sources over the next few decades. In just a few short decades wind energy has matured dramatically, making wind one of the fastest growing sources of electricity in the world today. Due to technological advancements, policy initiatives, and economic drivers, wind energy is now able to make a cost-competitive contribution to our growing energy needs.

But on the other side, we know that Wind power is a stochastic energy source with localized and non-centralized dispatch provision. Wind power production introduces new challenges in operation of a power system. Wind power production is continuously variable and difficult to predict.

Although weather forecasting can benefit wind prediction, increasing reliance on wind generation and greater integration of wind farms in established power networks means that coordination of energy generation is essential.

More flexibility should be added to wind power system in order to address those challenges. When wind availability is lower than expected, other conventional generation must help meet loads demand; conversely, wind plant is often curtailed or shut down to keep the system operating at normal conditions if wind speeds exceed expected or even safe limits. One possible solution is to introduce new storage facilities or using storage capabilities already available in the power system. Depending on the relative capacities of the wind and hydropower facilities, wind integration may provide changes in the way hydropower facilities operate in order to provide balancing, reserves or energy storage. Hydropower plant can feasibly be used to balance generation and compensate for fluctuations in wind

based on a simple model of summated power output, from wind and hydro inputs, which follow a provisional dispatch schedule.

In this paper, we use the optimization method of coordinated Hydro and Wind Power control which is mainly proposed using Phasor Measurement Units (PMUs) in relation with Discrete Fourier Transform (DFT). Phasor Measurement Technology is one of the advanced tools in this area which improve overall performance of the power system. By applying PMU with very high sampling rate (30 samples per seconds), snapshots of a power system for different behaviors are taken because instantaneous data is the heart of real time estimation. Here MATLAB based phasor measurements units have been used for estimating the samples of input signal, which were framed by using the Fourier Transform Techniques. The proposed method for the coordination operating scheme along with the discussion of major issues in combined wind and hydro power plant.

II. PHASOR MEASUREMENT UNIT

II.1 DEFINITION OF PHASOR

A pure sinusoidal waveform can be represented by a unique complex number known as a phasor. It has a certain amplitude and a phase angle at a particular time, where the values keep changing with time.

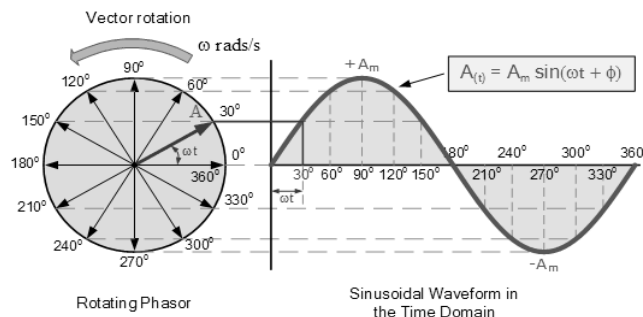

Fig 1: General Phasor Diagram

In three phase AC power systems, usually a set of phasors is defined as the three complex cube roots of unity, graphically represented as unit magnitudes at angles of 0, 120 and 240 degrees. By treating polyphase AC circuit quantities as phasors, balanced circuits can be simplified and unbalanced circuits can be treated as an algebraic combination of symmetrical circuits. This simplifies the work required in electrical calculations of voltage drop, power flow, and short-circuits currents. The phase angle is often given in degrees, and the magnitude in RMS value rather than the peak amplitude of the sinusoid.

II.2 PHASOR MEASUREMENT UNIT

PMU is a device which measures the electrical waves on an electricity grid using a common time source for synchronization. Time synchronization allows synchronized real-time measurements of multiple remote measurement points on the grid. The resulting measurement is known as a synchrophasor. They are time-synchronized numbers that represent both the magnitude and phase angle of the sine waves found in electricity, and are time-synchronized for accuracy. They are measured by high-speed monitors i.e. Phasor Measurement Units that are 100 times faster than SCADA.

Synchrophasor provides information of voltage or current phasor with reference to time. The information is in the form of time signal provided by global positioning system (GPS) and this signal is generated at 1 pulse per second (1 pps) by GPS. The synchronization is achieved by using a sampling clock which is phase-locked to the one-pulse-

per-second signal provided by a GPS receiver. The receiver may be built in the PMU, or may be installed in the substation and the synchronizing pulse distributed to the PMU and to any other device which requires it. The time tags are at intervals that are multiples of a period of the nominal power system frequency.

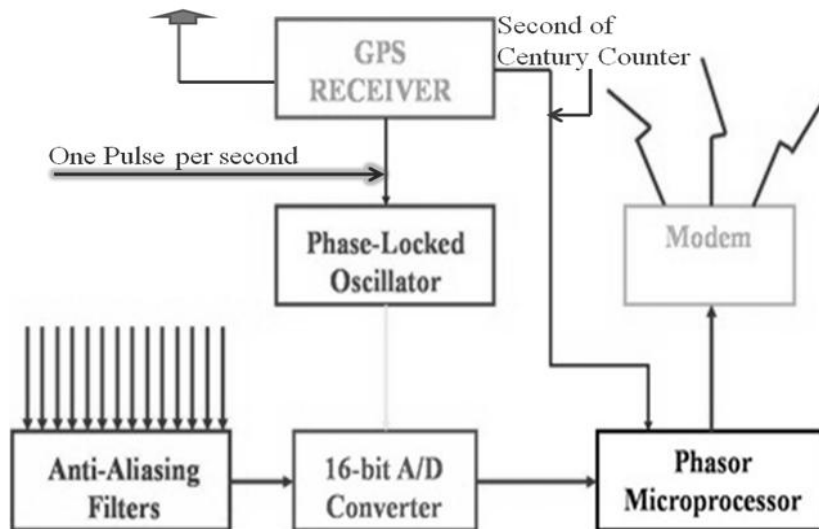

Fig 2: Phasor Measurement Unit Implementation

III. APPLICATIONS OF PMU

The conventional method (SCADA) used in power system application has some limitations such as the limitations of control techniques, algorithms, operational boundaries, data measurement speed and accuracy. So, it is very difficult to get real time system behavior or to make a dynamic analysis of the power system. Phasor Measurement Units can be used efficiently in Wide Area Monitoring System (WAMS). Today, WAMS is becoming more popular in the latest technologies for upgrading the traditional electric grid. Recently, the WAMS has become the powerful system to do the real time monitoring and for control of the power system. Some applications of PMUs are listed below to improve power system performance.

III.1. CALCULATION OF LINE PARAMETERS

If we use the Wide area measurement system, the data at the end of the line can be used for line parameters calculation which helps in comparing design data also. Continuous monitoring of line parameter and its calculation helps in modeling, fault location detection and for line outage detection.

III.2. OSCILLATION MONITORING

For the power system, small signal oscillations are very important to observe in real time, which are electromechanical oscillation caused by generator angles oscillating each other. In WAMS, this oscillation is observed by the frequency variation caused by the machine rotor and the frequency spectrum is calculated through DFT in PMUs. The electromechanical oscillation if remains for a longer time, it may damage the generator and thus it must be damped.

III.3 REAL TIME MANAGEMENT

In the real power system, to manage demand with the economic aspect without effecting transmission limits is very difficult. In power system, all the lines having their own thermal capability, voltage and stability margin which are pre-calculated. Then, to run the power system in a true manner, line is compared with nominal transfer capacity. The real time high speed accurate data obtain with PMU can improve congestion management and reduces excessive margins.

III.4. POWER SYSTEM ANALYSIS

WAMS refers to the possibility of visualizing a wide area of the electrical grid with PMUs. From measured data, a surface plot of an angle measured can be possible by using PMUs which are located in widely dispersed location across a power system. As the earlier power system did not have time synchronized recorders and loggers, it is difficult to analyze the event. But in WAMS, a GPS based PMU is used for time synchronization that cuts down time coordination problem from hours to seconds.

III.5 VOLTAGE STABILITY

In the power system, voltage stability plays a major role because voltage instability for a long time led to blackouts. Therefore, voltage stability needs careful monitoring. With the help of measurement taken from WAMS, voltage stability assessment becomes easy, fast, and precise. Moreover, the voltage monitoring taken by placing PMUs at each end of a transmission line become very easy tool and the power margin can be evaluated securing voltage stability on the line.

III.6 POWER SYSTEM PROTECTION

In conventional protection system, the system acted in response to faults irrespective of the existing condition in a predetermined manner. But Adaptive relaying assumes system characteristics and protection data should be coordinated with existing conditions. Out of step relays and line relays gives best protection and reliability. PMU provides an accurate measure of line impedance for fault, location. In WAMS, the backup zone is constantly supervised by PMUs and hence false tripping is avoided. PMU uses Wide area measurements to control for load swing or fault.

Also, PMUs is used to get depth observability. It means the voltage phasor and line current of the connected bus can be measured immediately. Moreover, the application of the PMU are greatly reduced the act of data acquisition equipments and tools required throughout the network.

IV. WORKING AND OPERATION

Our objective is to present a MATLAB based PMU, which uses Discrete Fourier Transform (DFT) algorithm, which is primarily employed for the coordination of Wind power with other conventional power plant. The MATLAB platform can process simulated power system WAMS based network, which usually consists of DFT technique equipped with system control. It is proposed that this simulated network will present the given algorithms and substitution involved in the phasor measurement process. Finally, the GPS used can transmit and receive the information from the synchronized phasor unit.

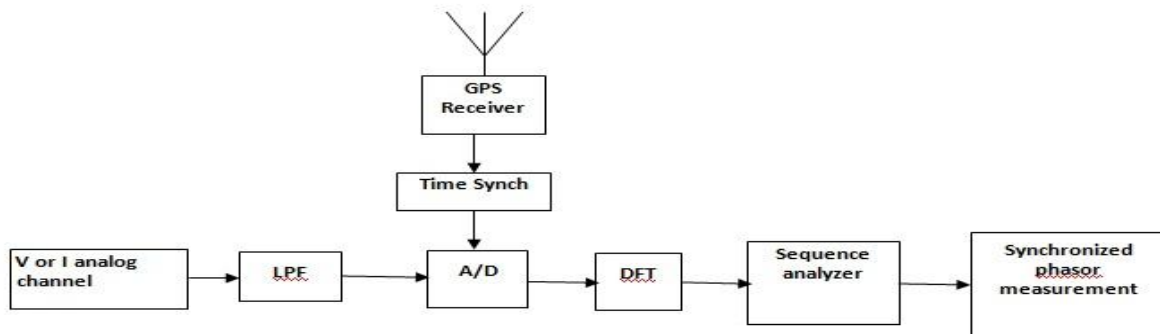

Fig 3. Block Diagram of PMU control working unit

This synchronized unit can be applied for coordinating the wind power with other reliable conventional source. Wind generation is an unreliable resource in terms of medium or long term availability. However hydro plant can be accurately scheduled. In order to control the output of a hydropower plant according to the output of a wind power plant, at least one PMU should be installed on the bus of hydropower plant and another one on the bus of wind power plant. The DFT applied PMU unit will analyse the response of both the control systems. A communication channel is given to connect the two PMUs for data exchange, in order to ensure that the sum of wind and hydro generation power follow the required dispatch, alongside conventional power plant. If the power from the wind plant is not enough to feed the loads, then the PMU unit will control the bus that tend to receive power from the hydro unit.

V. MATLAB BASED PMU WITH DFT ALGORITHM

Discrete Fourier Transform (DFT) is used for estimating the Fourier transform of small number of samples for input signal $x(t)$. On the real time in the power system, to achieve the voltage and current phasor synchronously, DFT algorithm has been used. MATLAB Simulink blocks are used for finding out the positive sequence component from the available signals. By using relationship of Fourier series coefficients with DFT algorithm, the phasor for k^{th} are obtained.

First of all DFT can be described by considering the Pure sinusoidal input signal in the following form:

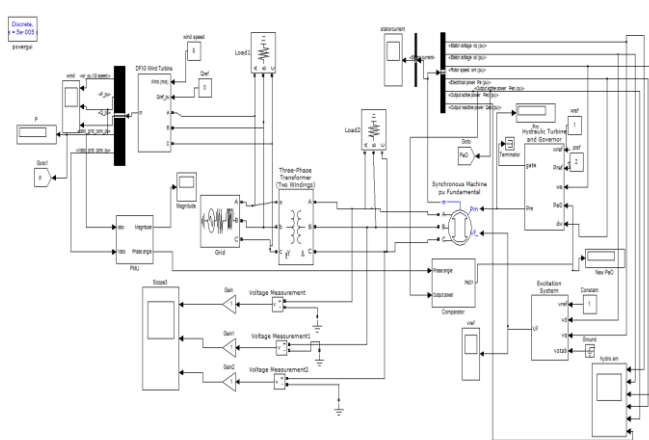

Fig 4. Simulink Diagram of PMU control working unit

$$x(t) = X_m \cos(\omega t + \theta) \quad (1)$$

where, ω = frequency of signal (radian per second);

θ = phase angle (radian);

X_m = Peak amplitude of the signal.

So, $X_m/\sqrt{2}$ is the RMS value of the signal $x(t)$ and which is helpful to calculate active and reactive power for AC Network.

$$x(t) = \text{Re} \{ X_m e^{j(\omega t + \theta)} \} \quad (2)$$

$$x(t) = [\{ e^{j\omega t} \} X_m e^{j\theta}] \quad (3)$$

Here, the term $e^{j\omega t}$ can be ignored by considering the frequency is ω and it can be represented by complex value X in terms of phasor representation.

$$X = X_r + j X_i \quad (4)$$

$$X = (X_m / \sqrt{2}) (\cos \theta + j \sin \theta) \quad (5)$$

Let us consider the harmonics which is usually found in the AC signals. Hence let's take the signal $x(t)$ is sampled N times per period of 50Hz signal, which is the standard frequency in our country, to generate the any order of harmonic component is given by,

$$X(k) = \frac{2}{N} \sum_{m=0}^{N-1} x(n) e^{-j 2\pi km / N} \quad (6)$$

where,

k = Order of the Harmonic,

N = Total number of Sample per window,

$n = n_{th}$ number of sample,

$m = m_{th}$ number of sample = $(n-1)_{th}$ number of sample,

$x(n)$ = Discrete Signal

$$\omega = 2\pi f, \quad f = \frac{1}{TsN}$$

$$\omega = \frac{2\pi}{TsN}$$

$$\theta = \frac{2\pi}{NT} \quad t = \frac{2\pi n}{N} \quad (\text{where } t = NT)$$

Now (7) can be expanded using (6), and it is rewritten as,

$$X(k) = [\frac{2}{N} \sum_{m=0}^{N-1} x(n) \cdot \cos(\frac{2\pi m}{N})] - j [\frac{2}{N} \sum_{m=0}^{N-1} x(n) \cdot \sin(\frac{2\pi m}{N})] \quad (7)$$

For the RMS value,

$$X(k) = \frac{1}{\sqrt{2}} [\frac{2}{N} \sum_{m=0}^{N-1} x(n) \cdot \cos(\frac{2\pi m}{N})] - j [\frac{2}{N} \sum_{m=0}^{N-1} x(n) \cdot \sin(\frac{2\pi m}{N})]$$

$$X(k) = \left[\frac{\sqrt{2}}{N} \sum_{m=0}^{N-1} x(n) \cdot \cos\left(\frac{2\pi m}{N}\right) \right] - j \left[\frac{\sqrt{2}}{N} \sum_{m=0}^{N-1} x(n) \cdot \sin\left(\frac{2\pi m}{N}\right) \right] \quad (8)$$

The RMS value of amplitude for voltage or current signal and phase angle of any of these signals can be obtained as:
Phase angle,

$$\theta = \tan^{-1} \left(\frac{\frac{\sqrt{2}}{N} \sum_{m=0}^{N-1} x(n) \cdot \sin\left(\frac{2\pi m}{N}\right)}{\frac{\sqrt{2}}{N} \sum_{m=0}^{N-1} x(n) \cdot \cos\left(\frac{2\pi m}{N}\right)} \right) \quad (9)$$

$$\text{RMS Amplitude, } X_{\text{rms}} = (X_r + X_i) / 2 \quad (10)$$

So, (8) gives the fundamental FFT equation to find out the any order harmonic component. PMU can only measure fundamental signals. So take k=1 in the equation. Moreover, (7) is the expansion of (6) which gives real and imaginary part of this Fourier Transform equation. Equation (9) gives the angle and (10) gives the RMS amplitude of measuring signal.

VI. SIMULATION RESULTS

Thus the Fourier transform decomposes a function of time signal into the frequencies that make it up. In the test system, four different contingencies are created to compare the behavior of variation of different waveforms. Here, reference signal generated in MATLAB simulated PMU is compared with system signals during normal condition.

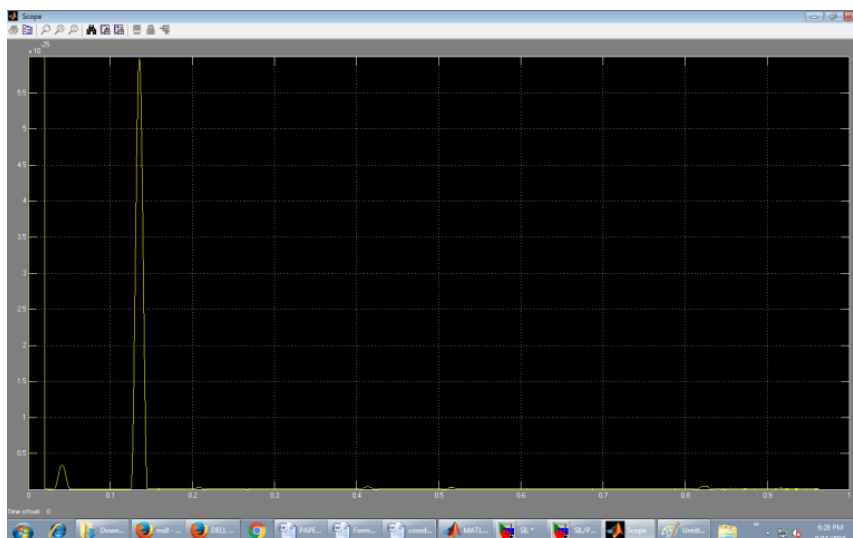

Fig 5. Output Waveform

In the PMU control unit, the control functions for the dispatch schedule of both the wind and hydro power plants are pre-installed. Transmission line length between two buses may be of several km and on each bus PMU is connected. Each PMU is synchronized with GPS and transfers data through the communication line. At the particular time, using the Fourier Transform Technique, the PMUs measure the amplitude and phase angle of both the wind and hydro conventional power plant, based on which the output power of each unit is determined. Thus, the optimized

International Journal of Innovative Research in Science, Engineering and Technology

An ISO 3297: 2007 Certified Organization

Volume 6, Special Issue 14, August 2017

Two Days National Conference on Modernization in Engineering Science (NCMES 2K17)

23rd-24th March 2017

Organized by

Dept. of EEE, Sri Krishna College of Engineering & Technology, Coimbatore 641 008, Tamil Nadu, India

operation of coordinated power plants can be seen using PMU connected between those plants. MATLAB Simulink can be used for the purpose of achieving phasor synchronization between the power output of the systems.

VII. CONCLUSION

In this paper, we proposed a DFT based PMU model, which primarily can be used in Power system coordination of power plants. This method can be implicated with further experimentation with MATLAB, and then DFT based Control can be applied on the bus between wind and hydro so that the accurate dispatch schedule can be provided. Generation scheduling is a complex problem. Using wind and hydro generation to compliment conventional generation scheduling offers benefits in terms of price and load balancing.

With the growing interest in PMUs and WAMS throughout the world, it is clear that these systems will be implemented in most major transmission networks.

This implementation can also be helpful in increasing our national economy in the world arena, by making the power system reliable, accurate and efficient. The new approach to collaboration of wind and hydro power can also offset the limitation of wind availability. Ultimately, this ability will lead to the use of PMUs for improving protection and control functions. The goal of such improvements is to make the power system less immune to failures and to reduce the possibility of such failures when they do occur. Undoubtedly, it can become a successful component in our Smart Grid.

REFERNCES

- [1] Jaime De La Ree, "Synchronized Phasor Measurement Applications in Power Systems", IEEE TRANSACTIONS ON SMART GRID, VOL. 1, NO. 1, JUNE 2010.
- [2] V. Salehi, A. Mazloomzadeh and O. Mohammed, "Development and implementation of a phasor measurement unit for real-time monitoring, control and protection of power systems," in Power and Energy Society General Meeting, 2011 IEEE, pp. 1-7, (2011).
- [3] P. Cruz, H.M.I. Pousinho, R.Melício, V.M.F. Mendes " Optimal coordination on wind-pumped-hydro operation", Conference on Electronics, Telecommunications and Computers – CETC 2013
- [4] Julija Matevosyan, "On the Coordination of Wind and Hydro Power".
- [5] Virender Singh, Ajay Kumar, Navdeep Batish, "Simulation and Analysis of Integrated WindPower with Small Hydroelectric Hybrid PowerSystem for Transient Stability".
- [6] A. G. Endegnanew, E. V. Øyslebø, D. Huertas-Hernando, B.H. Bakken, "Coordinated Control between Wind and Hydro Power Systems through HVDC Links"
- [7] Florina Scarlatache, Gheorghe Grigoraş, "Optimal Coordination of Wind and Hydro Power Plants in Power Systems"
- [8] Qiyu Chen, Tim Littler, Haifeng Wang, "APPLICATION OF PMUs TO COORDINATE HYDROELECTRIC AND WIND POWER PLANT OPERATION"
- [9] Salehi-Dobakhshari, A.; Ranjbar, A. M., "Application of synchronized phasor measurements to wide-area fault diagnosis and location," *Generation, Transmission & Distribution, IET*, vol.8, no.4, pp.716, 729, April 2014.
- [10] Chao Zhang; Zhiqian Bo; Baohui Zhang; Klimek, A.; Min Han; Jiancheng Tan, "An integrated PMU and protection scheme for powersystems," *Universities Power Engineering* .