

# Three Unit Series–Parallel Systems with Common Cause and Environmental Error Failures by Probabilistic Analysis

K. Uma Maheswari<sup>1</sup>, A. Mallikarjuna Reddy<sup>2</sup>

Department of Mathematics, Shri Shirdi Sai Institute of Science & Engineering, Vadyampeta, Anantapuramu, (A.P.),  
India<sup>1,2</sup>

**ABSTRACT:** In this paper it is proposed for three unit series parallel system the nature of reliability proposed a better model for common cause and environmental error failures by three unit series parallel system. We consider three models of a three unit series parallel system consisting of the units A, B and C which is in function state. When A is functioning and either B or C are in functioning state and we assume that the system is subjected to common cause and environmental error failures.

**KEYWORDS:** Series-parallel system, common cause, Environmental error, Gamma distribution, Availability

## I. INTRODUCTION

In reality the systems under consideration may not be modelled as series or parallel systems. If the functional diagram suggests that the successful operation of the systems depends on the proper operation then we say that the system configuration is a series. A system with ‘m’ components is known as m-unit parallel system if and only if the successful functioning of any one of the components leads for the system success. In this chapter we consider a three unit series parallel system and we study the reliability and availability analysis of the system is subjected to common cause and environmental error failures.

## II. ASSUMPTIONS AND NOTATION

We consider three models of a three unit series-parallel system consisting of the units A, B and C which is in functioning state only, when A is functioning and either B or C are in functioning state, and we assume that the system is subjected to common-cause and environmental error failures.

### ASSUMPTIONS

At any time epoch ‘t’ the system can be in one of the following seven states.

- 0 → The state of the system with all the three components functioning state.
- 1 → The state of the system with the component A and one of the components B or C is in functioning state.
- 2 → The failed state of the system corresponding to the failure A from the state ‘0’.
- 3 → The failed state of the system due to the failure of the component A from state 1.
- 4 → The failure state of the system corresponding to the failure of both the components B and C while A is functioning.
- 5 → The failed state of the system due to environmental error from state ‘0’.
- 6 → The failed state of the system due to common cause.

# International Journal of Innovative Research in Science, Engineering and Technology

(An ISO 3297: 2007 Certified Organization)

Vol. 6, Special Issue 13, July 2017

## NOTATION

T	=	Time
S	=	Laplace transform variable
$\lambda$	=	Constant failure rate of the units A and B
$\lambda_{C1}$	=	Constant common cause failure rate of the system from the state '0'.
$\lambda_e$	=	Constant environmental error failure rate of the system
$\lambda_{C2}$	=	Constant common cause failure rate of the system from state 1.
$\lambda_A$	=	Constant failure rate of the unit A.
$\mu$	=	Constant repair rate of a unit.
$\mu_1$	=	Constant repair rate of the system from the state 4.
$\mu_2$	=	Constant repair rate of the system from the failed state 3.
$P_k^{(x,t)}$	=	Probability density (with respect to repair time) that the failed system is in state k and has an elapsed repair time of x, for k = 5, 6.
$\mu_k(x), q_k(x)$	=	Repair rate and probability density function of repair time respectively when the failed system is in state k and has an elapsed repair time of x, for k = 5, 6.
$\beta$	=	The shape parameter of the Gamma probability density function.

## III. ANALYSIS

CASE – I: With the above notation the transition diagram of the system is given by  
The system of integral differential equations associated with this model are given by

$$\frac{dp_0(t)}{dt} + (2\lambda + \lambda_{c1} + \lambda_e + \lambda_A)p_0(t) = \mu p_1(t) + \mu_A p_2(t) + \mu_1 p_4(t) + \mu_2 p_3(t) + \int_0^{\infty} p_5(x,t)\mu_5(x)dx + \int_0^{\infty} p_6(x,t)\mu_6(x)dx \quad (1)$$

$$\frac{dp_1(t)}{dt} + (\lambda_A + \lambda + \lambda_{C2} + \mu)p_1(t) = 2\lambda p_0(t) \quad (2)$$

$$\frac{dp_2(t)}{dt} + \mu_A p_2(t) = \lambda_A p_0(t) \quad (3)$$

$$\frac{dp_3(t)}{dt} + \mu_2 p_3(t) = \lambda_A p_1(t) \quad (4)$$

$$\frac{dp_4(t)}{dt} + \mu_1 p_4(t) = \lambda_A p_1(t) \quad (5)$$

$$\left( \frac{\partial}{\partial x} + \frac{\partial}{\partial t} + \mu_5(x) \right) p_5(x,t) = 0 \quad (6)$$

$$\left( \frac{\partial}{\partial x} + \frac{\partial}{\partial t} + \mu_6(x) \right) p_6(x,t) = 0 \quad (7)$$

$$p_5(0, t) = \lambda_e p_0(t) \quad (8)$$

$$p_6(0, t) = \lambda_{c1} p_0(t) + \lambda_{c2} p_1(t) \quad (9)$$

## International Journal of Innovative Research in Science, Engineering and Technology

(An ISO 3297: 2007 Certified Organization)

Vol. 6, Special Issue 13, July 2017

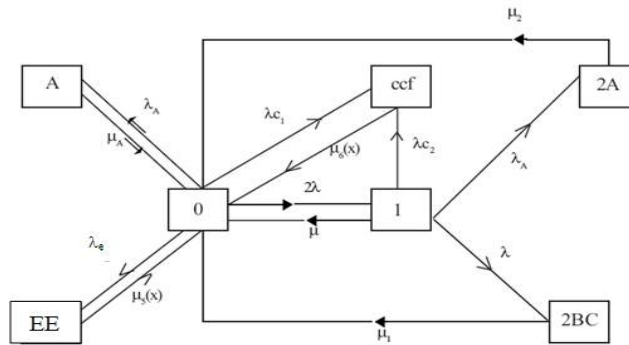

The initial conditions are given by

$$P_0(0) = 1 \text{ and } p_j(0) = 0 \text{ for } j = 1, 2, 3, 4$$

$$P_k(x,0) = 0 \text{ for } k = 5, 6$$

By taking Laplace Transformations the above equations reduces to

$$s p_0(s) - 1 + (2\lambda + \lambda_{c1} + \lambda_e + \lambda_A) p_0(s) = \mu p_1(s) + \mu_A p_2(s) + \mu_1 p_4(s) + \mu_2 p_3(s)$$

$$+ \int_0^{\infty} p_5(x,s) \mu_5(x) dx + \int_0^{\infty} p_6(x,s) \mu_6(x) dx \quad (10)$$

$$s p_1(s) + (\lambda + \lambda_{c2} + \mu + \lambda_A) p_1(s) = 2\lambda p_0(s) \quad (11)$$

$$s p_2(s) + \mu_A p_2(s) = \lambda_A p_0(s) \quad (12)$$

$$s p_3(s) + \mu_2 p_3(s) = \lambda_A p_1(s) \quad (13)$$

$$s p_4(s) + \mu_1 p_4(s) = \lambda p_1(s) \quad (14)$$

$$\left( \frac{\partial}{\partial x} + s + \mu_5(x) \right) p_5(x,s) = 0 \quad (15)$$

$$\left( \frac{\partial}{\partial x} + s + \mu_6(x) \right) p_6(x,s) = 0 \quad (16)$$

$$p_5(0,s) = \lambda_e p_0(s) \quad (17)$$

$$p_6(0,s) = \lambda_{c1} p_0(s) + \lambda_{c2} p_1(s) \quad (18)$$

From equations (11) to (14)

$$p_1(s) = \frac{2\lambda p_0(s)}{s + \lambda_A + \lambda + \lambda_{c2} + \mu}$$

$$p_2(s) = \frac{\lambda_A}{s + \mu_A} p_0(s)$$

$$p_3(s) = \frac{\lambda_A}{s + \mu_A} p_1(s) = \frac{2\lambda\lambda_A}{(s + \mu_2)(s + \lambda_A + \lambda + \lambda_{c2} + \mu)} p_0(s)$$

$$p_4(s) = \frac{\lambda}{s + \mu_1} p_1(s) = \frac{2\lambda^2}{(s + \mu_1)(s + \lambda_A + \lambda + \lambda_{c2} + \mu)} p_0(s)$$

From equation (10)

## International Journal of Innovative Research in Science, Engineering and Technology

(An ISO 3297: 2007 Certified Organization)

Vol. 6, Special Issue 13, July 2017

$$\begin{aligned}
 s p_0(s) - 1 + (2\lambda + \lambda_{c1} + \lambda_e + \lambda_A) p_0(s) &= \frac{2\lambda\mu}{s + \lambda_A + \lambda + \lambda_{c2} + \mu} p_0(s) \\
 &+ \frac{\mu_A \lambda_A}{s + \mu_A} p_0(s) + \frac{2\lambda^2 \mu_1}{(s + \mu_1)(s + \lambda_A + \lambda + \lambda_{c2} + \mu)} p_0(s) \\
 &+ \frac{2\lambda \lambda_A \mu_2}{(s + \mu_2)(s + \lambda_A + \lambda + \lambda_{c2} + \mu)} p_0(s) \\
 &+ \int_0^\infty p_5(x, s) \mu_5(x) dx + \int_0^\infty p_6(x, s) \mu_6(x) dx
 \end{aligned}$$

From equation (15)

$$\begin{aligned}
 \frac{\partial}{\partial x} p_5(x, s) &= (s + \mu_5(x)) p_5(x, s) \\
 \Rightarrow \frac{\frac{\partial}{\partial x} p_5(x, s)}{p_5(x, s)} &= -(s + \mu_5(x))
 \end{aligned}$$

Integrating we obtain

$$(\log p_5(x, s))_0^x = -sx - \int_0^x \mu_5(x) dx$$

$$\frac{\log p_5(x, s)}{p_5(0, s)} = -sx - \int_0^x \mu_5(x) dx$$

$$\frac{p_5(x, s)}{p_5(0, s)} = e^{-sx - \int_0^x \mu_5(x) dx}$$

$$\Rightarrow p_5(x, s) = p_5(0, s) e^{-sx - \int_0^x \mu_5(x) dx}$$

$$= \lambda_e e^{-sx - \int_0^x \mu_5(x) dx} p_0(s)$$

Again from equation (16) we have

$$p_6(x, s) = p_6(0, s) e^{-sx - \int_0^x \mu_6(x) dx}$$

$$= \left( \lambda_{c1} + \frac{2\lambda \lambda_{c2}}{s + \lambda_A + \lambda + \lambda_{c2} + \mu} \right) p_0(s) e^{-sx - \int_0^x \mu_5(x) dx} \tag{20}$$

From equation (10) we have

$$s p_0(s) - 1 + (2\lambda + \lambda_{c1} + \lambda_e + \lambda_A) p_0(s) = \frac{2\lambda\mu}{s + A_1} p_0(s) + \frac{\mu_A \lambda_A}{s + A_2} p_0(s) + \frac{2\lambda^2 \mu_1}{(s + A_1)(s + A_3)} p_0(s)$$

## International Journal of Innovative Research in Science, Engineering and Technology

(An ISO 3297: 2007 Certified Organization)

Vol. 6, Special Issue 13, July 2017

$$\begin{aligned}
 & + \frac{2\lambda\lambda_A\mu_2}{(s+A_1)(s+A_4)} p_0(s) + \int_0^\infty \lambda_h e^{-sx - \int_0^x \mu_5(x) dx} \mu_5(x) dx p_0(s) + \\
 & + \int_0^\infty \left( \lambda_{c1} + \frac{2\lambda\lambda_{c2}}{(s+A_1)} \right) p_0(s) e^{-sx - \int_0^x \mu_6(x) dx} \mu_6(x) dx
 \end{aligned}$$

On simplification we obtain

$$p_0(s) = \frac{((s+A_1)(s+A_2)(s+A_3)(s+A_4))}{Q(s)} \tag{21}$$

### SPECIAL CASE MODELS - AVAILABILITY

As a special case we assume that the repair time distribution of the failed system will follow Gamma distribution with shape parameter  $\beta$ . In this case one has

$$q_5(x) = \frac{\mu_5(\mu_5 x)^{\beta-1} e^{-\mu_5 x}}{\Gamma(\beta)}; t \geq 0, \beta > 0 \tag{22}$$

$$\text{and } q_6(x) = \frac{\mu_6(\mu_6 x)^{\beta-1} e^{-\mu_6 x}}{\Gamma(\beta)}; t \geq 0, \beta > 0 \tag{23}$$

(1) We assume that the shape parameter  $\beta=1$ . In this case the repair of the failed system is constant and its repair times are exponentially distributed. Hence we

$$q_5(x) = \mu_5 e^{-\mu_5 x} \tag{24}$$

$$\text{and } q_6(x) = \mu_6 e^{-\mu_6 x} \tag{25}$$

Taking Laplace transform we obtain

$$q_5(s) = \frac{\mu_5}{s + \mu_5} \text{ and } q_6(s) = \frac{\mu_6}{s + \mu_6} \tag{26}$$

substituting these results into equation (21) one obtain

$$p_0(s) = \frac{N_0(s)}{s D_0(s)}$$

where

$$N_0(s) = S^6 + B_1S^5 + B_2S^4 + B_3S^3 + B_4S^2 + B_5S + B_6$$

$$D_0(s) = S^6 + B_7S^5 + B_8S^4 + B_9S^3 + B_{10}S^2 + B_{11}S + B_{12}$$

The time dependent system availability  $A_V(t)$  for this system is given by

$$\begin{aligned}
 AV(t) &= P_0(t) + P_1(t) \\
 &= (G_1 + G_8) + (G_2 + G_9) e^{s1t} + (G_3 + G_{10}) e^{s2t} + (G_4 + G_{11}) e^{s3t} \\
 &\quad (G_5 + G_{12}) e^{s4t} + (G_6 + G_{13}) e^{s5t} + (G_7 + G_{14}) e^{s6t}
 \end{aligned}$$

Limiting availability (steady state)  $A_V$  of the system is given by

$$A_V(t) = \lim_{t \rightarrow \infty} Lt A_V(t) = G_1 + G_8$$

### IV. DISCUSSION

The availability versus time for various values of environmental error and the parameter  $\beta$  are plotted. From this table & graph the availability of the system decreases with time more rapidly for the value of  $\beta=1$ .

# International Journal of Innovative Research in Science, Engineering and Technology

(An ISO 3297: 2007 Certified Organization)

Vol. 6, Special Issue 13, July 2017

**Table – 1  $\beta = 1$**

S. No.	Time	Availability		
		$\lambda_e = 0.00002$	$\lambda_e = 0.00003$	$\lambda_e = 0.00004$
1	0.6	0.85	0.80	0.73
2	0.9	0.72	0.69	0.61
3	1.3	0.56	0.52	0.50
4	1.8	0.52	0.48	0.44
5	2.1	0.46	0.42	0.41
6	2.5	0.43	0.34	0.33
7	2.9	0.41	0.33	0.32

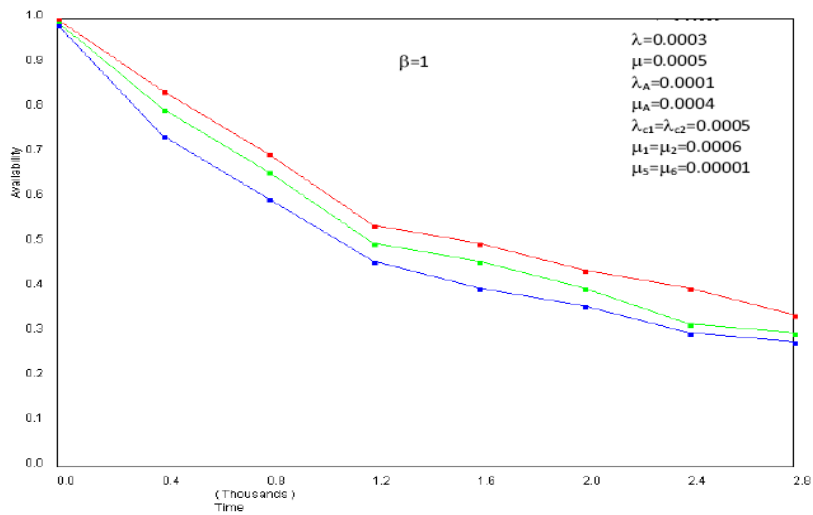

### REFERENCES

1. M Dhillon, B.S and O.C Anude: Common cause failure analysis of a parallel system with warm stand by, Micro-Electronics and Reliability – Vol.33, No.9, PP.1321-1342, (1993).
2. Dhillon, B.S and Yan, N. : Reliability and Availability analysis of warm stand by systems with common-cause failures and human errors. Micro Electron. Reliability Vol.32, No. PP.561-575, (1992).