

International Journal of Innovative Research in Science, Engineering and Technology

(A High Impact Factor, Monthly, Peer Reviewed Journal)

Visit: www.ijirset.com

Vol. 7, Issue 7, July 2018

Low Cost Manual Briquette Making Machine Using Scotch Yoke Mechanism

Dr. Y.M. Sonkhaskar, Harjot Singh Saluja, Rishabh Srivastava, Ritvick Parikh, Utkarsh Singhai

Associate Professor, Department of Mechanical Engineering, RCOEM, Katol Road, Nagpur, India

U.G. Student, Department of Mechanical Engineering, RCOEM, Katol Road, Nagpur, India

U.G. Student, Department of Mechanical Engineering, RCOEM, Katol Road, Nagpur, India

U.G. Student, Department of Mechanical Engineering, RCOEM, Katol Road, Nagpur, India

U.G. Student, Department of Mechanical Engineering, RCOEM, Katol Road, Nagpur, India

ABSTRACT: Today, renewable sources of energy have become very promising. Conventional or non-renewable sources of energy are finite and are depleting very rapidly. There are various forms of renewable energy sources among which, biomass is one of the important source of renewable energy available. India, which is known for its agriculture, has a huge potential of converting biomass into renewable form of energy. Biomass when compacted or densified into definite shape and size is termed as a Biomass Briquette. These are a renewable source of energy and avoid adding carbon to atmosphere. Biomass briquettes are the bio-fuel substitute to coal and firewood. There are different technologies available for conversion of loose biomass into briquettes. These include piston press, screw press, roller press and hydraulic press. There is machinery available which employ these technologies but these machinery are very heavy and expensive and are commercially used in industries. Therefore, keeping an average Indian farmer in mind, there is a need to build a manual driven briquette making machine, which can provide them with sustainable fuel and is also a potential source of income. In this paper, an attempt is made to try and build a manually driven machine by using some simple mechanism. The mechanism which is used for making this machine is Scotch Yoke mechanism. In an agricultural driven country like India this machine provides a method of converting field waste into a useful product.

KEYWORDS: Scotch yoke mechanism, briquettes, binders, manually driven.

I. INTRODUCTION

Developing countries like India produce large quantities of agricultural residue but they are used inefficiently causing extensive pollution to the environment. The major residues are rice husk, coffee husk, coir pith, groundnut shells, cotton stalk, and mustard stalk. Direct burning of this loose biomass in conventional grates is associated with very low thermal efficiency and widespread air pollution. Apart from this there are other problems associated with this loose biomass like transportation, storage and handling. Briquetting of this biomass can prevent the problem of pollution while at the same time, making use of these domestic energy resources. Briquetting is the densification of loose agricultural residue material to produce more compacted solid composites by applying pressure. Briquettes are a renewable source of energy and thus it can contribute toward cleaner environment. The briquetting of biomass material leads to increase net calorific value per unit volume, reduces transportation cost, improves bulk density and also improves handling characteristics. There has been recent push to replace the burning of fossil fuel with biomass. The replacement of this non-renewable resources with renewable source i.e. biomass waste would lower the overall pollution of world. Different technologies are available for briquetting but this machinery are very heavy, expensive and also consume very large amount of power. In countries like India where in many rural areas supply of electricity is limited, there is a need to create an alternative to the commercially available heavy machinery. In this paper we have tried to create low cost briquette making machine by using simple mechanism like scotch yoke mechanism.

International Journal of Innovative Research in Science, Engineering and Technology

(A High Impact Factor, Monthly, Peer Reviewed Journal)

Visit: www.ijirset.com

Vol. 7, Issue 7, July 2018

II. MANUAL BRIQUETTE MAKING MACHINE

Our model of manual briquette making machine consist of four major components:

1. Scotch yoke mechanism
2. Compression chamber
3. Hopper
4. Ejector pads

Scotch yoke mechanism forms the working mechanism of this manual machine. Scotch yoke mechanism is a second inversion of double slider crank chain. It consists of two sliding pair and two revolute pair. Scotch yoke mechanism is used to convert rotary motion into reciprocating motion. It is a very simple mechanism which can be easily constructed. The operation of this mechanism is also very simple. This type of mechanism can be easily automated. The compression chamber used in this model is a simple cylinder in which raw material is compressed with the help of a piston. The cylinder is provided with an inlet on its surface for the entry of raw material. Diameter of cylinder will determine the diameter of briquette. Hopper is connected with the inlet of compression chamber i.e. cylinder for feeding the raw material. Ejector pads are used for ejecting the briquette from compressing chamber after the raw material is compressed to adequate densities.

The creo model of the setup of manual briquette making machine is shown below

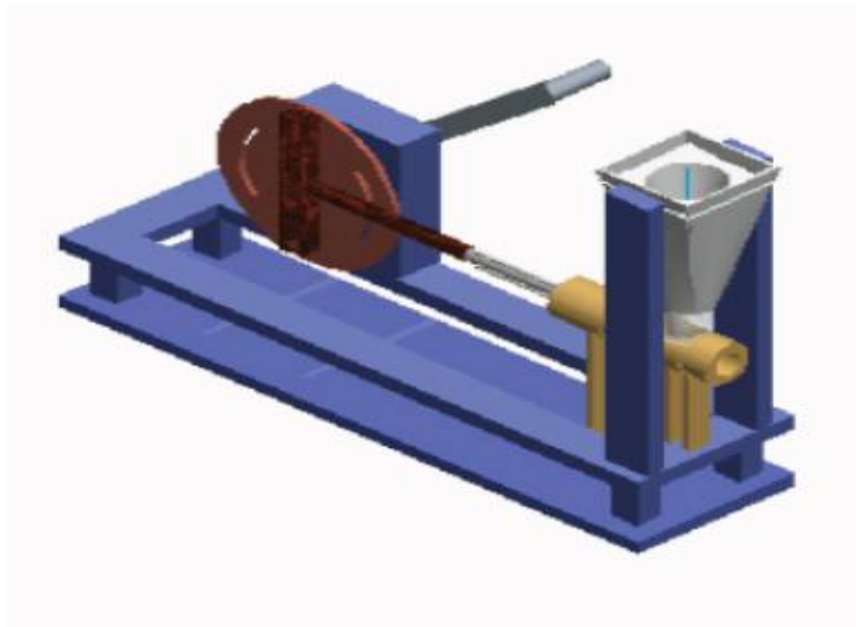

Figure 1: Creo model of manual driven briquette making machine

International Journal of Innovative Research in Science, Engineering and Technology

(A High Impact Factor, Monthly, Peer Reviewed Journal)

Visit: www.ijirset.com

Vol. 7, Issue 7, July 2018



Figure 2: Actual photograph of the set up

III. WORKING

The working of this manual briquette making machine is very simple due to the scotch yoke mechanism. Scotch Yoke mechanism directly converts rotary motion into reciprocating motion. The rotary motion to the wheel is given by the operator with the help of handle. As the wheel rotates, sliding yoke which is connected to the wheel reciprocates. Arm of the sliding yoke is extended which is connected with the piston. This reciprocating motion of piston is used to compress the raw material. When the wheel is being rotated, during half rotation, the sliding yoke moves forward and in the next half rotation it moves backward. When sliding yoke moves backward, the inlet of the hopper is opened and the material falls in to the compressing chamber and when it moves forward, it compresses the material. After compressing the material briquette is formed. The briquette is ejected with the help of ejector pads.

IV. EXPERIMENTATION

A number of experiments were conducted to study the different densities obtained by this model. Raw material used for this model was saw dust as it was easily available and also it is in the form of fine particles. Binding material also plays a very important role as it is necessary for briquette to hold its shape after it has been dried. There are two types of binders, combustible and non-combustible. Combustible binder like paper pulp, cow dung, starch water add to the heating value along with the binding property while non-combustible binder like clay, cement, mineral adhesives only provide binding property. Binding material like paper pulp, starch water, wheat flour etc. was used. Different composition of binder was used. The ratio of binder used is around 35:65.

V. RESULT

Raw material	Binder	Density
Saw dust	Paper pulp + water	656 kg/m ³
Saw dust	Paper pulp + starch water	723 kg/m ³

International Journal of Innovative Research in Science, Engineering and Technology

(A High Impact Factor, Monthly, Peer Reviewed Journal)

Visit: www.ijirset.com

Vol. 7, Issue 7, July 2018

VI. CONCLUSION

Biomass briquette can contribute a lot as it is a renewable form of energy. The utilization of biomass in the form of briquette is very less and there is tremendous scope to increase this process. We have tried to build a manual operated briquette making machine which can contribute toward this social cause and also it can act as source of extra income. We have also strived to keep the overall cost of the briquette machine so that it becomes affordable to farmers and becomes an alternate source of income.

REFERENCES

1. Yeshwant M. Sonkhaskar, Deshpande V.S. and Modak J.P (2013) "Design and Fabrication of Dual Powered Mini Pelletizer" Applied Mechanics and Material Vol. 465-466 pp 242-247, (ISSN: 1660-9336), ISBN-13: 978-3-03785-933-9
2. Bapat A. R. and Modak, J. P. (1993) "Manually driven flywheel motor operates wood turning process" Contemporary Ergonomics, Proc. Ergonomics Society Annual Convention 13-16 April Edinburg, Scotland, pp 352-377
3. Modak, J.P. (2005) "Influence of development and human powered process machine and its impact on energy management of rural and interior sector", Proceeding of National Conference on Energy Management in Changing Business Scenario, (EMCBS 2005), 8-9, BITS Pilani.
4. D. Plistil, M. Brozek, A. Roy "Mechanical characteristics of standard fuel briquettes on biomass basis" (2005) Research Institute Of Agricultural Engineering, Czech Republic.
5. Manoj Kumar Sharma, Gohil Priyank, Nikita Sharma, "Biomass Briquette Production: A Propagation of Non-Convention Technology and Future of Pollution Free Thermal Energy Sources", American Journal of Engineering Research (AJER) Volume-04, Issue-02, pp-44-50.
6. Ch. A. I. Raju, K. Ramya Jyothi, M. Satya. U .Praveena, "Studies On Development Of Fuel Briquettes For Household And Industrial Purpose ". IJRET: International Journal of Research in Engineering and Technology eISSN: 2319-1163 | pISSN: 2321-7308.
7. Shreya Shukla, Savita Vyas, "Study of Biomass Briquettes, Factors Affecting Its Performance and Technologies Based On Briquettes", IOSR Journal of Environmental Science, Toxicology and Food Technology (IOSR-JESTFT), Volume 9, Issue 11 Ver. II (Nov. 2015), PP 37-44
8. Muhammad SN, Muhammad AA, Abdul N and Anjum M, "Design and Fabrication of Biomass Extruder of 50 mm Diameter Briquette Size", Innovative Energy & Research, Volume 5 • Issue 1 • 1000128.
9. Kamalnath.V, Kameshwaran.S, "Design and Analysis of Dual Side Shaper Using Scotch Yoke Mechanism", International Journal of Innovative Research in Science, Engineering and Technology (IJIRSET) , Vol. 6, Issue 7, July 2017
10. Eduardo A. Sánchez, Milagros B. Pasache, Marcos E. García, "Development of Briquettes from Waste Wood (Sawdust) for Use in Low-income Households in Piura, Peru", Proceedings of the World Congress on Engineering 2014 Vol II, WCE 2014, July 2 - 4, 2014, London, U.K., ISBN: 978-988-19253-5-0, ISSN: 2078-0958 (Print); ISSN: 2078-0966 (Online)
11. Križan P., Matuš M., Šooš L, "Design of Pressing Chamber of Briquetting Machine with Horizontal Pressing Axis", 11th International Scientific Conference Novi SAD, Serbia, September 20-21, 2012.
12. Collins N. Nwaokocha, Olasunkanmi O. Akinyemi, "Development of a Dual-Mode Laboratory-Sized Pelletizing Machine", Leonardo Journal of Sciences, Issue13, July-December 2008, p. 22-29, ISSN 1583-0233