

# **Analysis of Load Frequency Control in Two Area Thermal-Hydro using Fuzzy and Conventional Controller**

Deepti Prakash Bodra<sup>1</sup>, Pradeep Kumar Shill<sup>2</sup>, Dr. Prasanta Kumar Satapathy<sup>3</sup>

P.G. Student, Department of Electrical Engineering, C.E.T, Bhubaneswar, Odisha, India<sup>1</sup>

P.G. Student, Department of Electrical Engineering, C.E.T, Bhubaneswar, Odisha, India<sup>2</sup>

Professor, Department of Electrical Engineering, C.E.T, Bhubaneswar, Odisha, India<sup>3</sup>

**ABSTRACT:** This work involves the analysis of Load Frequency Control (LFC) of 2 different area and analysis of its system parameters. Though LFC helps in maintaining uniform frequency, to divide the load between the generators and to control the tie-line interchange schedule, we compare the values of undershoot, overshoot and settling time in fuzzy and some conventional controller (i.e. PI and PID). Considering area-1 as thermal and area-2 as hydro, a step load perturbation of 1% is applied in area-1. We develop the model of the system in MATLAB Simulink environment, and we compare for each case using the proposed controller. The output response of proposed fuzzy logic controller exhibit better performance than both PI and PID controller.

**KEYWORDS:** Load Frequency Control, Fuzzy Logic Controller, Conventional Controller, Tie-line, Two Area.

## **I. INTRODUCTION**

The General Role of Power System is to transmit generated electric power to consumer end, consumer can be small or big depending on it, and it comes in different size from those with single small generator to multiple generators that loads to the gigantic resulting the cost is also affected so to minimise the loss from every aspect in terms of money, time and power, the supply of load demand should match with generation [1]. So the important function is to make both the active and reactive power steady. In terms of LFC active power is considered because for frequency active power demand is controlled failing to which the machine speed will vary with consequent change in frequency (maximum permissible change in frequency is  $\pm 0.5$  Hz. Similarly for reactive power the voltage is controlled within its prescribed limits ( $\pm 2.5$  v). With the time passing load demand vary for peak period and low period. Here in LFC frequency regulation is seen. The objectives of LFC are to provide zero steady-state error of frequency and tie-line exchange variations, high damping of frequency oscillations and decreasing overshoot of the disturbance so that the system is not too far from the stability. In this work Fuzzy Logic Controller (FLC) is used. This type of controller adds a pole at origin resulting in system type so reducing the steady state error. System load is never steady using controller these can be controlled. When there is a uncontrolled case more oscillation, negative overshoot be observed but while comparing to conventional controller and propose work result is shown to see better performances of dynamic responses.

## **II. TWO AREA THERMAL-HYDRO POWER SYSTEM**

A two area thermal-hydro power system is connected through a power line each area feeds its user pool and tie-line allows the electrical power to flow between areas [1] [2]. Frequency control is accomplished by two different control actions. The primary speed control makes the initial coarse adjustment of the frequency. By its action, the various generators in the control area track a load variation and share it in proportion to their capacities. The speed of the response is limited only by the natural time lags of the turbine and the system itself. Depending upon the turbine type

# International Journal of Innovative Research in Science, Engineering and Technology

(A High Impact Factor, Monthly, Peer Reviewed Journal)

Visit: [www.ijirset.com](http://www.ijirset.com)

Vol. 7, Issue 5, May 2018

the primary loop typically responds within 2-20 sec. The secondary speed control takes over the fine adjustment of the frequency by resetting the frequency error to zero through an integral action. The relation between the speed and load can be adjusted by changing load reference set point. The adjustment of the load reference set point is accomplished by operating the speed changer motor. The output of each unit at a given system frequency can be varied only by changing its load reference, which in effect moves the speed-droop characteristics up and down. The speed governing system is used to adjust the frequency. A governor adjusts the turbine valve/gate to bring the frequency back to the nominal or scheduled value. For power and load sharing among the generator connected to the system, speed regulation or droop characteristics must be provided. The speed-droop or regulation characteristics is obtained by adding a steady state feedback loop around the integrator. Fig 1 shows 'Two Interconnected System'.



Fig 1: Two interconnected control areas

### III. MATHEMATICAL MODELLING OF TWO AREA THERMAL-HYDRO POWER PLANTS

There are two types approach one is i) Transfer function approach and another is ii) State variable approach. Easiest way is to approach on Transfer function approach because it can be easily designed due to numerator and denominator for which determining pole and zero and other is stability is easily noticed on s-plane, as it says for stability it should stay on left half of s-plane [10]. For analysing the system performance, the mathematical model is required, then only control system is designed for which the modelling should exists before. The mathematical modelling of Thermal and Hydro is considered in this work. The tie-line modelling is developed to make the power out and in so it is necessary to work for its transfer function **Fig 3** shows 'Block Diagram of two area LFC'.

Power transported out of area 1 is given by  $P_{tie,1} = \frac{|V_1||V_2|}{X_{12}} \sin(\delta_1^0 - \delta_2^0)$  (1)

Where  $\delta_1^0, \delta_2^0$  are the power angles of equivalent machines of the two areas, As the incremental power angles are integrals of incremental frequencies, we can write as  $\Delta P_{tie,1} = 2\pi T_{12} (\int \Delta f_1 dt - \int \Delta f_2 dt)$  (2)

$T_{21} = \frac{|V_1||V_2|}{P_{r1}X_{12}} \cos(\delta_1^0 - \delta_2^0)$  =synchronizing coefficient (3)

Similarly for area 2 given as  $\Delta P_{tie,2} = 2\pi T_{21} (\int \Delta f_1 dt - \int \Delta f_2 dt)$  (4)

Where  $T_{21} = \frac{|V_2||V_1|}{P_{r2}X_{21}} \cos(\delta_2^0 - \delta_1^0) = (\frac{P_{r1}}{P_{r2}}) T_{12} = a_{12}T_{12}$  (5)

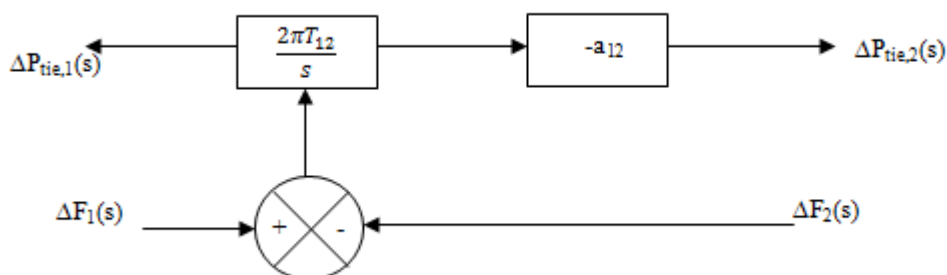

Fig 2: Transfer function of Tie-line

## International Journal of Innovative Research in Science, Engineering and Technology

(A High Impact Factor, Monthly, Peer Reviewed Journal)

Visit: [www.ijirset.com](http://www.ijirset.com)

Vol. 7, Issue 5, May 2018

The Tie-line is used in two area to interconnect between the two control areas.  
Using the Tie-line two area Thermal-Hydro systems are constructed which is shown in fig 3.

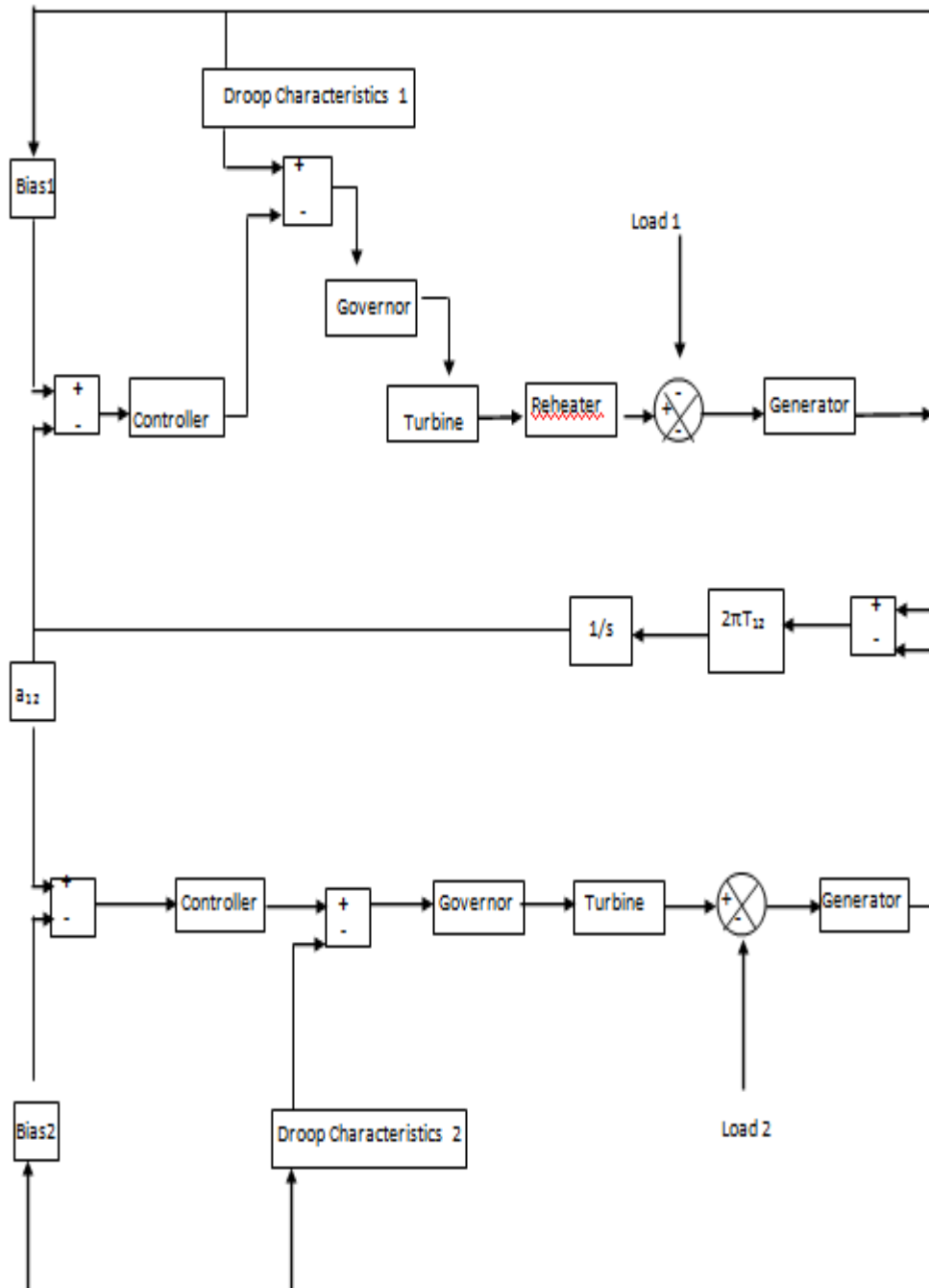

Fig 3: Block diagram of Thermal-Hydro Using Tie-line

# International Journal of Innovative Research in Science, Engineering and Technology

(A High Impact Factor, Monthly, Peer Reviewed Journal)

Visit: [www.ijirset.com](http://www.ijirset.com)

Vol. 7, Issue 5, May 2018

## IV. CONTROLLERS USED

- a. Conventional PI Controller
- b. Conventional PID Controller
- c. Fuzzy Logic Controller(FLC)

These Controllers used for comparison to see whose system parameters are evaluating best result in terms of its overshoot, undershoot and settling time.

For **PI** the proportional gain provides stability and high frequency response. The integral term insures that the average error is driven to zero. Advantages of PI include that only two gains must be tuned, that there is no long-term error, and that the method normally provides highly responsive systems. The predominant weakness is that PI controllers often produce excessive overshoot to a step command.

For **PID** the equation The mathematical equation for the PID controller is given as  $y(t) = K_p e(t) + K_i \int_0^t e(\tau) d\tau + K_d \frac{d}{dt} e(t)$

Where  $y(t)$  is the controller output and  $r(t)$  is the input. A proportional controller ( $K_p$ ) will have the effect of reducing the rise time and will reduce but never eliminate the steady-state error. An integral control ( $K_i$ ) will have the effect of eliminating the steady-state error, but it may make the transient response worse. A derivative control ( $K_d$ ) will have the effect of increasing the stability of the system, reducing the overshoot, and improving the transient response. The limitation conventional PI and PID controllers are slow and lack of efficiency in handling system non-linearity. Generally these gains are tuned with help of different optimizing methods such as Ziegler Nicholas method, Hit and trial Method (manual Control) and optimal control solution. The values obtained in this work is through optimal control solution and the values obtained in optimal control solution method for PI Controller.

$K_p = -0.8147$  and  $K_d = -0.1270$

For PID controller  $K_p = -0.0005$ ,  $K_i = -0.6126$  and  $K_d = -0.8790$

There are some uncertainties in load and change in system parameter is seen. So to avoid such situation soft computing method is used as Fuzzy Logic Controller to tuned continuously.

C. Fuzzy Logic Controller: The development of power system characteristics is complex and variable in conventional controller in short difficult in hard computing methods where we use mathematical functions, values to describe the function, but in FLC soft computing is used. For it there are some rules to define which is easy in implementation because it can be replaced easily with conventional controllers to get fast and good response in Load frequency problems. Fuzzy logic controller can be more powerful in solving large scale with respect to conventional controller, which proved to be slower. FLC is designed to minimize fluctuation on system outputs. It mainly consists of 3 stages namely Fuzzification, Inference rule engine and Defuzzification. For LFC the operator assumed as error and change in error. The Fuzzy Controller takes the input as  $ACE_1$  and  $ACE_2$  which is  $ACE_i = F_i B_i + P_{tie}$  (6)

Where  $B_i$  is the frequency bias, FLC has used in both thermal-hydro using Triangular Membership function to provide better dynamic response in error and change in error with range -0.1 to 0.1 in thermal and -0.8 to 0.6 in hydro with the rules of 25. The dynamic response is then compared with conventional controllers.

The rules are same for both the thermal and hydro. The following membership function used are NL-Negative large, NS-Negative Small, PL- Positive Large, PS- Positive Small, and Z-Zero change. Accordingly the rule is made for hydro and thermal, its rule is used in tie-line for that reason the rule is kept same for both.

# International Journal of Innovative Research in Science, Engineering and Technology

(A High Impact Factor, Monthly, Peer Reviewed Journal)

Visit: [www.ijirset.com](http://www.ijirset.com)

Vol. 7, Issue 5, May 2018

Ce E	NL	NS	Z	PS	PL
NL	PL	PL	PL	PS	Z
NS	PL	PS	PS	Z	Z
Z	PL	PS	Z	NS	NL
PS	Z	Z	NS	NS	NL
PL	Z	NS	NL	NL	NL

Fig 5:

## V. SIMULATION RESULTS

Simulink model of interconnected Thermal-Hydro using Fuzzy and its conventional PI and PID controllers are shown and its result is also shown.

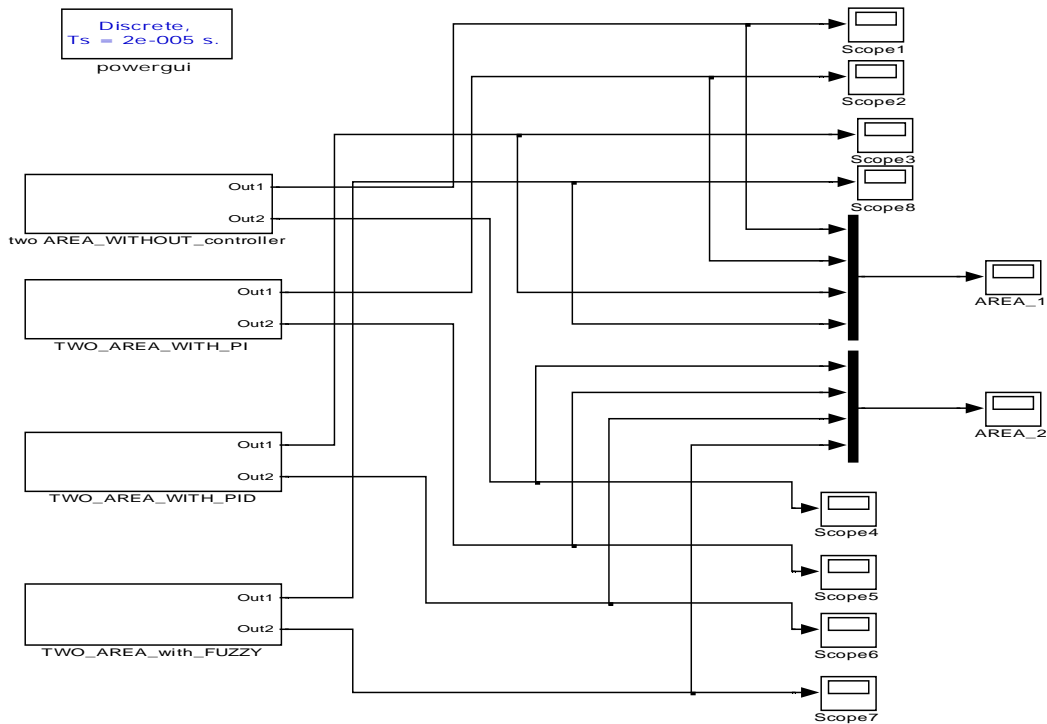

Fig 6 Matlab Design of Area1 and 2

# International Journal of Innovative Research in Science, Engineering and Technology

(A High Impact Factor, Monthly, Peer Reviewed Journal)

Visit: [www.ijirset.com](http://www.ijirset.com)

Vol. 7, Issue 5, May 2018

## SUBSYSTEM OF FUZZY

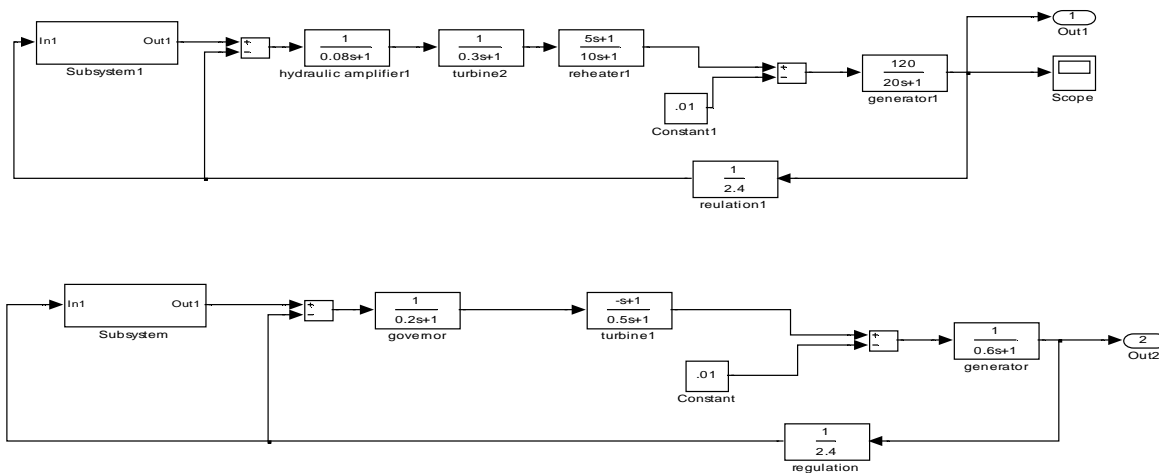

Fig 7: A Subsystem of Fuzzy Matlab Model

Similarly, different subsystems are designed without controller, with PI and PID controller and Fuzzy Logic Controller for the comparative study. The results are as follows:

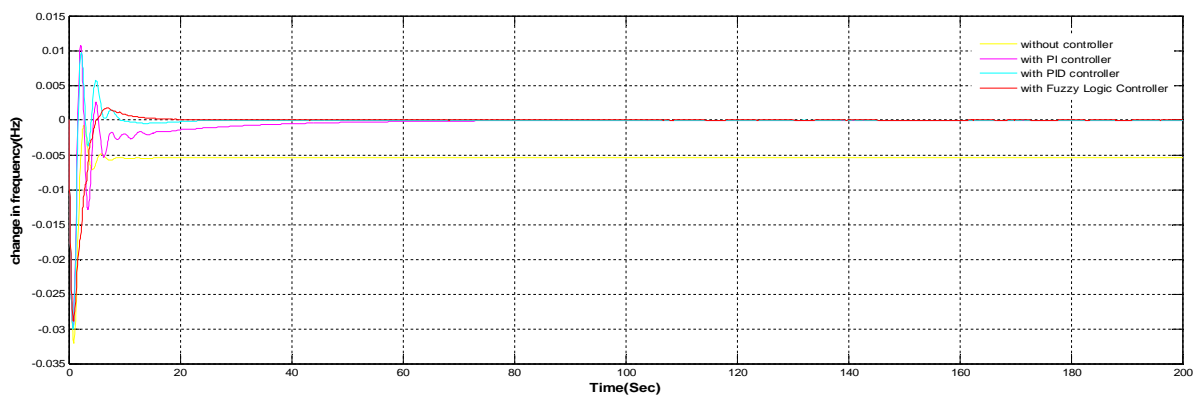

Fig 8: For Area1

# International Journal of Innovative Research in Science, Engineering and Technology

(A High Impact Factor, Monthly, Peer Reviewed Journal)

Visit: [www.ijirset.com](http://www.ijirset.com)

Vol. 7, Issue 5, May 2018

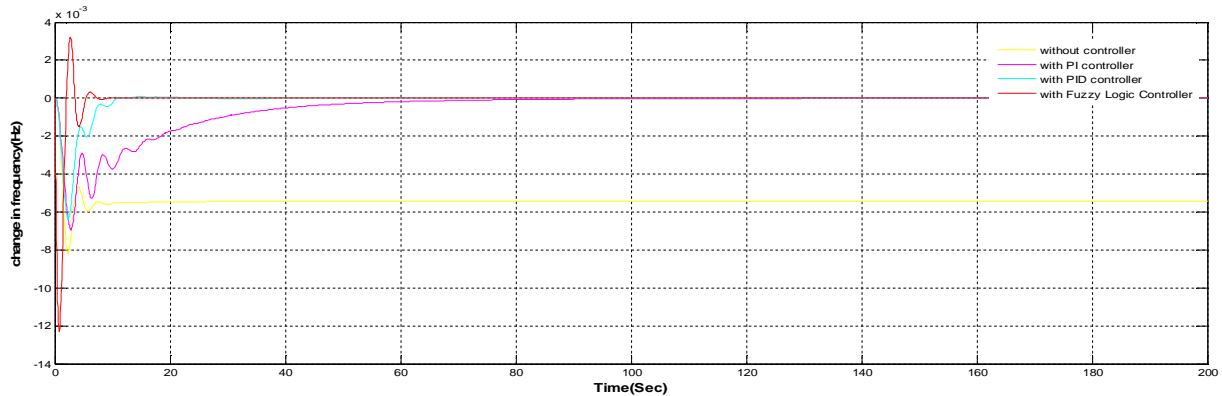

Fig 9: For Area 2

### Result @thermal

Parameters	System with PI controller	System with PID controller	System with Fuzzy Logic controller
Overshoot(Hz)	0.01	0.01	0.002
Undershoot(Hz)	-0.03	-0.03	-0.028
Settling Time(Sec)	24	24	22

### Result @ hydro

Parameters	System with PI controller	System with PID controller	System with Fuzzy Logic controller
Overshoot(Hz)	0	0	0.003
Undershoot(Hz)	-0.007	-0.007	-0.012
Settling Time(Sec)	90	23	9

## VI.CONCLUSION

From the above work it can be conclude that fuzzy exhibit better performance than its conventional controller We have implemented the Simulink modelling as per foresaid requirement to check the settling time of its system parameters. The FLC have better control performance according to its data obtained on 1% load Perturbation. In short we can say that FLC is adequate for better quality and reliable electric power supply due to less settling time, less peak overshoot and quick rise time.

## REFERENCES

- [1] C. Concordia, L. K. Kirchmayer, "Tie-Line Power & Frequency Control of Electric Power Systems- Part II", AIEE Trans., vol. 73, part III-A, 1954, pp. 133-141 (1954).
- [2] Elgerd.O.I Energy system Theory: an introduction", New York: McGraw-Hill,. Electric (1982).
- [3] Chang CS, Fu W. Area load-frequency control using fuzzy gain scheduling of PI controllers. Electrical Power Syst Res;42:145-52 (1997).
- [4] B.Anand ,A Ebenezer jayakumar" fuzzy logic based load frequency control of thermal hydro power system with non-linearities(2009)
- [5] Kashyap Ramnand,S.s Sankeshwari and B.A.Patil,2013. Load frequency control using fuzzy Pi controller generation of Interconnected Hydro power system, International journal of emerging technologyand advanced engineering (2013).
- [6] Prajod, V.S. and M. Carolin Mabel, 2013. Design of PI controller using MPRS method for Automatic Generation Control of hydro power system, International Journal of Theoretical and Applied Research in Mechanical Engineering, 2(1): 1-7.(2013)
- [7] Rajaguru, V., R. Sathya and V. Shanmugam, 2015. Load Frequency Control in an Interconnected Hydro-Hydro Power System with Superconducting Magnetic Energy Storage Units, International Journal of Current Engineering and Technology 5(2): 1243-1248(2015).
- [8] Prabha Kundur,Power system stability and control,Newyork:McGraw-Hill,(1994).

## International Journal of Innovative Research in Science, Engineering and Technology

*(A High Impact Factor, Monthly, Peer Reviewed Journal)*

Visit: [www.ijirset.com](http://www.ijirset.com)

**Vol. 7, Issue 5, May 2018**

- [9] Shabani Hamed, Behrooz Vahidi and Majid Ebrahimpour, 2013. A robust PID controller based on Imperialist competitive algorithm for load frequency control of power systems, ISA Transactions, 52: 88-95.(2013).
- [10] Kashyap Ramanand and S.S. Sankeswari, 2014 A simulation model for LFC using fuzzy PID with interconnected hydro power systems, International Journal of Current Engineering and Technology, 3: 183-86(2014).
- [11] Ala Eldin Awouda & Rosbi Bin Mamat, "New PID Tuning Rule Using ITAE Criteria", International Journal of Engineering (IJE), Volume (3), Issue (6).
- [12] Mohan BM, Sinha A. Analytical structure and stability analysis of a fuzzy PID controller. Applied Soft Computing;8:749-58(2008).
- [13] Muthana T. Alrifai and Mohamed Zribi "Decentralized Controllers for Power System Load Frequency Control" ASCE Journal, Volume 5, IssueII, June, (2005).
- [14] Wadhwa C.L., Electrical Power Systems. 2010 Edition, New Age International Publisher, New Delhi.(2010).
- [15] Timothy.J.Ross.1995. Fuzzy logic with engineering application (1995).