

Artificial Neural Network based MPPT of Solar Photovoltaic Cells

I. Mohammed Sherif¹, Srivas Seshadri²

U.G. Student, School of Mechanical Engineering, VIT University, Vellore, Tamil Nadu, India¹

U.G. Student, School of Mechanical Engineering, VIT University, Vellore, Tamil Nadu, India²

ABSTRACT: We live in a world where the main source of energy is from fossil fuels deposited beneath the earth surface millions of years ago. Due to population explosion, our fossil fuel deposits have been exploited severely emitting large amounts of toxins in the environment that depletes the quality of human life. We all know that the most abundant source of energy available to us is solar energy, a renewable and non-depleting source. Conventionally, we harness solar energy using solar photovoltaic cells with an efficiency about 15%. The major setback in traditional solar PV cells is its inability to track maximum power point due to varying weather conditions. In this paper, we use artificial neural networks (ANN) to track the maximum power point of solar cells and to obtain maximum power at all time. The proposed model consists of a PV array, a MPPT controller with P&O algorithm, DC-DC buck boost converter, an inverter control system powered by neural networks, an RLC band pass filter and a transformer to transmit the power. The entire system is simulated on MATLAB/Simulink and the results are validated for environmental conditions. The major outcomes of this model include increased power output to the grid making it easier for power transmission and reducing the distortions in the tracking maximum power. The results demonstrate us the importance of using neural networks in solar PV systems as it outperforms orthodox MPPT techniques.

KEYWORDS: Artificial Neural Networks, Maximum Power Point Tracking, DC-DC buck boost converter, Inverter, RLC circuit, PID controller, Transformer, MOSFET, Duty cycle.

I. INTRODUCTION

Solar energy extracted using PV cells can be directly used as DC power supply or can be stored in batteries and converted to an AC source for future purposes. The uncertainty of our weather conditions makes it very difficult to extract maximum power hence artificial neural networks is implemented to exterminate this issue. There are two major parts in this system – DC power extraction from solar PV array and AC power transmission to the grid. The DC-AC conversion is carried out by the H-bridge inverter system. The inverter operates only two switches at a time and the voltage across it is measured leading to the DC-AC conversion. In today's world, we need a PV system that can extract solar energy efficiently and accurately without much discrepancy.

The maximum power point tracking (MPPT) using P&O algorithm works by fine-tuning the array voltage and measuring the power. The measured power $P(k)$ is compared with the preceding array power $P(k-1)$ and if the power increases, further amendments are done. This process continues until no further changes in power are observed. These techniques find major applications in solar PV systems and wind power systems. A number of MPPT algorithms have been designed and implemented in tracking controllers but the P&O algorithm stands as a simple and effective method to track MPP as stated by Radwan et al. [1]. Incremental Conductance method offers higher speed in tracking MPP but suffers from increased distortions around the maximum power point, hence P&O algorithm is preferred [2].

These distortions can be reduced significantly by implementing neural networks in our PV system. A number of non-conventional methods inculcating neural networks are burgeoning at a rapid pace. Traditionally, they are found using temperature and solar irradiance as the input parameters for ANN imposing a need for additional sensors making it economically less appealing [3,4]. Hence, in our paper we propose a method where current and voltage are used as

International Journal of Innovative Research in Science, Engineering and Technology

(A High Impact Factor, Monthly, Peer Reviewed Journal)

Visit: www.ijirset.com

Vol. 7, Issue 5, May 2018

inputs parameters to our two layer ANN control system that predicts the power delivered to the grid eliminating the need for temperature and irradiance sensors making it a low cost design.

The final part of this design is the integration of power to the grid where the stand-alone system is converted to a micro-grid at the point of common coupling. It is at this point that the low power PV system with RLC circuit is coupled with the load and transformer [5]. This paper comprises of five sections – introduction, related work, PV system implementing ANN to track MPP, experimental results and conclusion.

II. RELATED WORK

The varying solar irradiance poses a huge threat to the efficiency of the cells and our model solves this issue in a unique two layer neural network system where the voltage from the PV array is divided into two components - magnitude and angle and current is delayed by a single sample. The product of these two parameters gives the power delivered. The flow chart of the model is as follows.

1. A solar PV cell is designed in MATLAB / Simulink based on requirements and its input parameters are initialized
2. The initial Current – Voltage (I-V) and Power-Voltage (P-V) characteristics of the PV array obtained.
3. With voltage and current as input parameters, a P&O algorithm is developed which produces a duty cycle signal
4. A DC buck boost converter is made use of, which is connected to the PV array and an inverter switch control
5. The duty cycle produced by the MPPT controller is sent to the MOSFET gate
6. The output voltage is boosted by the DC buck boost converter compromising the output current
7. The inverter control system powered by Artificial Neural Networks compares the PV array power and grid power, which is the input for the 2-layer function fitting neural networks.
8. The neural network infers the data, processes it by biasing and then sends it to layer 1
9. The output of layer 1 is the input for layer 2 and after processing is mapped in the reverse direction and sent out to the control system.
10. The inverter control system compares the values and produces a pulsating signal which is responsible for the switching of inverters that produce AC output
11. The RCL filter, fine tunes the output voltage of distortions that are out of the range
12. The transformer at the point of common coupling with the grid steps up the voltage and transmits it.

III. PHOTOVOLTAIC SYSTEM – ANNBASD MPPT

This section discusses the major elements involved in setting up a solar PV system along with its control systems and grid integration in MATLAB/Simulink.

A. Photovoltaic Array

The PV array is a single diode based model consisting of a string of cells connected in series and parallel. The module employed is a five parameter block using light generated current, diode current, ideality factor, series and shunt resistance. The solar irradiance range varies from 800-1000 kW/m² and the cell temperature varies from 45C-25C. The I-V and P-V characteristics of the module with varying cell temperature and irradiance are shown in the Fig. 1 and Fig. 2. These curves are the basis on which the neural network training takes place.

International Journal of Innovative Research in Science, Engineering and Technology

(A High Impact Factor, Monthly, Peer Reviewed Journal)

Visit: www.ijirset.com

Vol. 7, Issue 5, May 2018

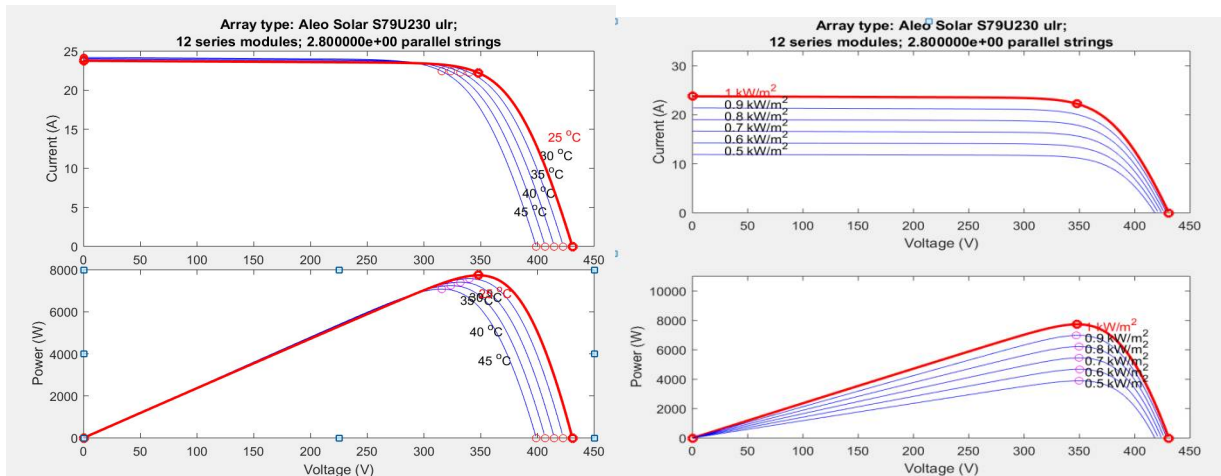

Fig.1. IV & PV graph with varying cell temperature

Fig. 2. IV & PV graph with varying solar irradiance

B. DC-DC boost converter

A boost converter enhances the input DC voltage to a higher level and supplies it to the output. In our proposed design, the boost converter has a diode and a MOSFET connected with capacitors on the input and output sides of the circuit to reduce the voltage ripples caused due to periodic variation of DC source, while a classic boost converter consists only of a diode and IGBT. The boost converter functions in two states – ON/OFF as represented schematically in the Fig. 3

ON State - The transistor in its ON state with its switch closed enables the current flow through the inductor charging itself. In this state, the load and the capacitors are in reverse polarity compared to the inductor and the capacitor discharges small amounts of current to the load.

OFF State -The transistor in its OFF state with its switch open enables the current flow through the diode from the inductor to the capacitor. This capacitor gets charged and the inductor discharges. This process repeats and the capacitor charges and discharges thereby increasing the voltage and decreasing it accordingly.

Fig. 10 shows the voltage from the PV array and Fig. 13 shows the boosted voltage by the DC-DC boost converter. It can be clearly seen that the PV voltage is boosted from 24.5 V to 90 V

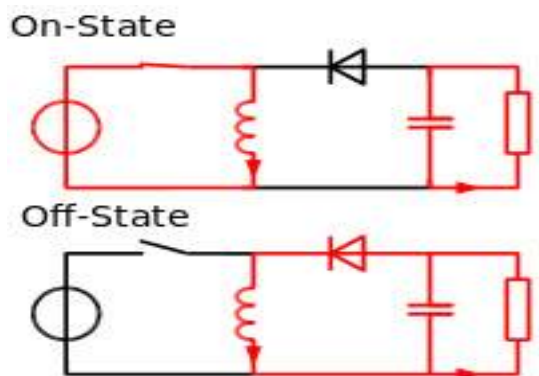

Fig. 3. ON/OFF state of DC-DC boost converter

International Journal of Innovative Research in Science, Engineering and Technology

(A High Impact Factor, Monthly, Peer Reviewed Journal)

Visit: www.ijirset.com

Vol. 7, Issue 5, May 2018

The duty cycle generated by the MPPT controller is the feed for DC-DC boost converters and the MOSFET switches producing stepped up voltage [8]. The output voltage (V_{out}) generated by the boost converter is always greater than the input voltage (V_{in}) and is validated by the formula where D is the duty cycle, $V_{out}/V_{in} = 1/(1-D)$

C. Maximum Power Point Tracking (MPPT)

MPPT algorithms are crucial in photovoltaic applications because the MPP of a solar panel fluctuates with the solar irradiation and temperature, so the use of MPPT hill climbing algorithms is mandatory to obtain the maximum power from a solar array. MPPT controller uses voltage $V(k)$ and current $I(k)$ from the PV array and it perturbs the voltage to obtain new values of power. The setup is automated with no manual adjustments required. This power $P(k)$ is then compared with the previous value $P(k-1)$ and a feedback of dP/dV is sent to the controller. When the power is increased, the operating voltage value is stepped up and vice versa. The global MPP is attained when the feedback returns a null value. The Fig. 6 demonstrates the flowchart of Perturb & Observe (P&O) algorithm.

MPPT controller generates duty cycle in order to create switching signals for the DC-DC converter. The switching signal is delivered to the gate of MOSFET permitting the boost converter to operate the solar PV system at optimum voltage and current so that the maximum power extraction is possible.

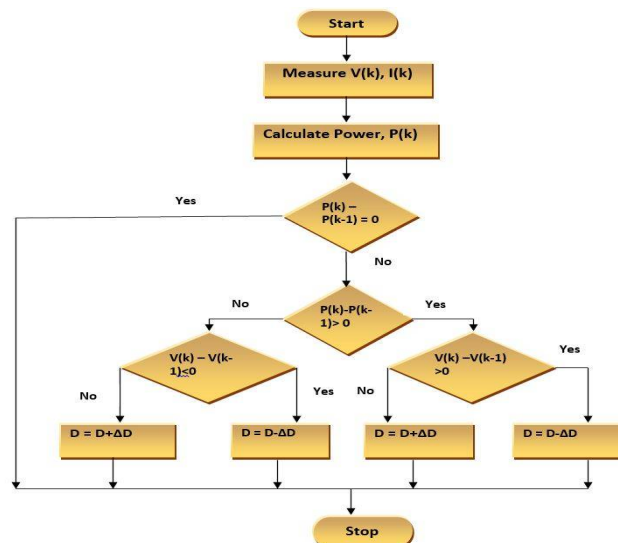

Fig. 4. P&O flowchart

D. H-bridge Inverter System

The H-bridge inverter is a single phase inverter which consists of 4 MOSFET switches (SW1, SW2, SW3 and SW4) as shown in Fig. 5. The inversion of DC source to AC occurs by operating two switches at a particular time. An AND operation is used between two sets of square wave signals and two sets of sinusoidal pulse width modulation signals to facilitate the inversion process. The 4 sets of switching signals can be classified into two groups – The MOSFETs SW1 & SW4 form the first group while MOSFETs SW2 & SW3 form the second. The mode of operation of switches are as follows

1. When the switches SW1 and SW4 are open, the load voltage will be equal to the boosted voltage (+Vdc)
2. When the switches SW1 and SW3 are open, the load voltage will be equal to zero
3. When the switches SW1 and SW2 are open, the circuit is short and the condition is known as shoot-through
4. When the switches SW2 and SW3 are open, the load voltage will be equal and opposite to the boosted voltage from the DC converter (-Vdc)
5. When the switches SW2 and SW1 are open, the load voltage will be equal to zero
6. When the switches SW2 and SW4 are open, the circuit is short and the condition is known as shoot-through.

International Journal of Innovative Research in Science, Engineering and Technology

(A High Impact Factor, Monthly, Peer Reviewed Journal)

Visit: www.ijirset.com

Vol. 7, Issue 5, May 2018

As you can see from point 1 and point 4, it is evident that the conversion of DC voltage to AC is carried out in two cycles – positive and negative. The inputs (IP1 & IP2) as shown in Fig. 7 are controlled using AND operator which switches one OFF while the other is ON to ease the conversion. [6,7]

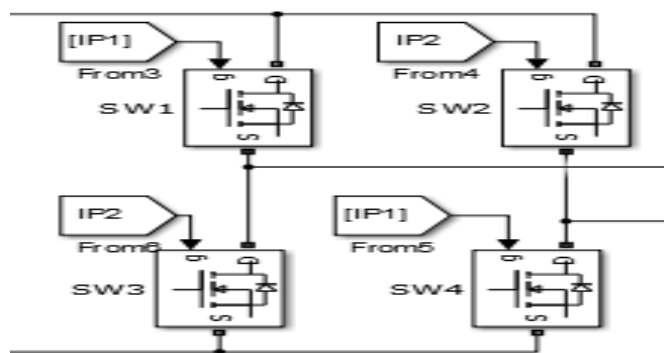

Fig. 5. H-bridge inverter

E. Artificial Neural Networks (ANN)

The ANN control system has to be trained before being used in the photovoltaic system [9-11]. The neural network is a powerful technique for mapping the input-output nonlinear function.

In our proposed design, we incorporate a two layer cascading neural network technique that predicts the PV array voltage at which the maximum power is attainable. These develop a non-linear relationship between the input and output with a hidden layer that functions with preferences like neurons of our brain. The hidden layer in our model is a two layer neural network as shown in Fig. 6 whose input parameters are an error function of power from the grid and boost converter. This is then sent to layer 1 with 10 neurons where a process input synthesizes the signal with weights and generates a tangent sigmoid transfer function. The output of layer 1 is the input for layer 2 with another set of 10 neurons that assigns weightage to the values and generates a pure linear transfer function. The cosine and sine components of array voltage is added to the output signal and is compared to a repeating signal using a relational operator. The relational operator produces binary output which generates the duty cycle responsible for inverter switching operations.

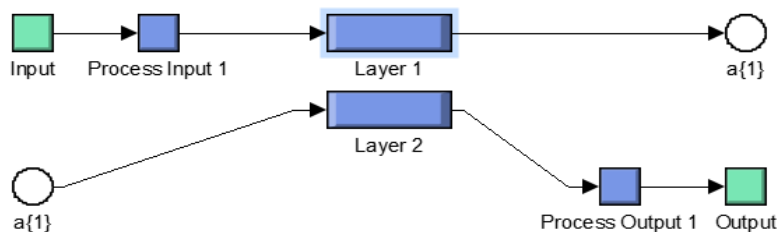

Fig. 6. Two layer neural networks

F. RLC Filters

The RLC circuit comprises of a resistor, inductor and capacitor which is used as a low band pass filter. A low band pass filter filters the signal between two specific frequency ranges. The inductor in the RLC circuit charges and capacitor discharges in resonance leading to oscillations in the circuit. This is sorted out by involving a resistor in the circuit that causes a damping effect decreasing the flow of current [12]. The damping effect reduces the harmonic distortions leading to a smoother transmission of power. The Fig. 7 shows the RLC circuit used in our MATLAB model.

International Journal of Innovative Research in Science, Engineering and Technology

(A High Impact Factor, Monthly, Peer Reviewed Journal)

Visit: www.ijirset.com

Vol. 7, Issue 5, May 2018

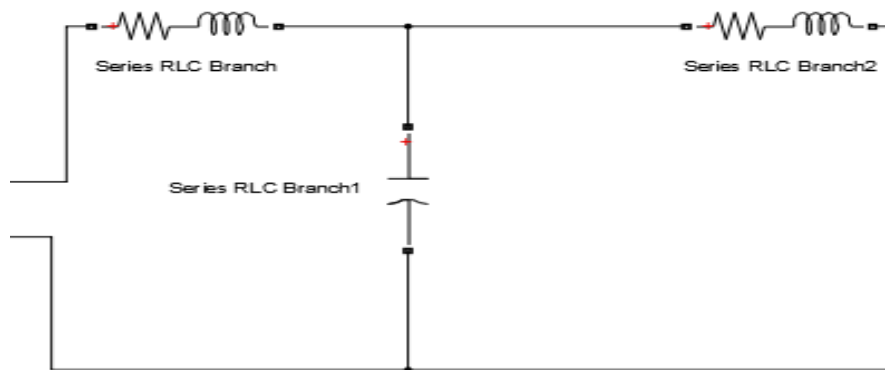

Fig. 7. RLC filter circuit

G. Simulink Model of ANN based MPPT

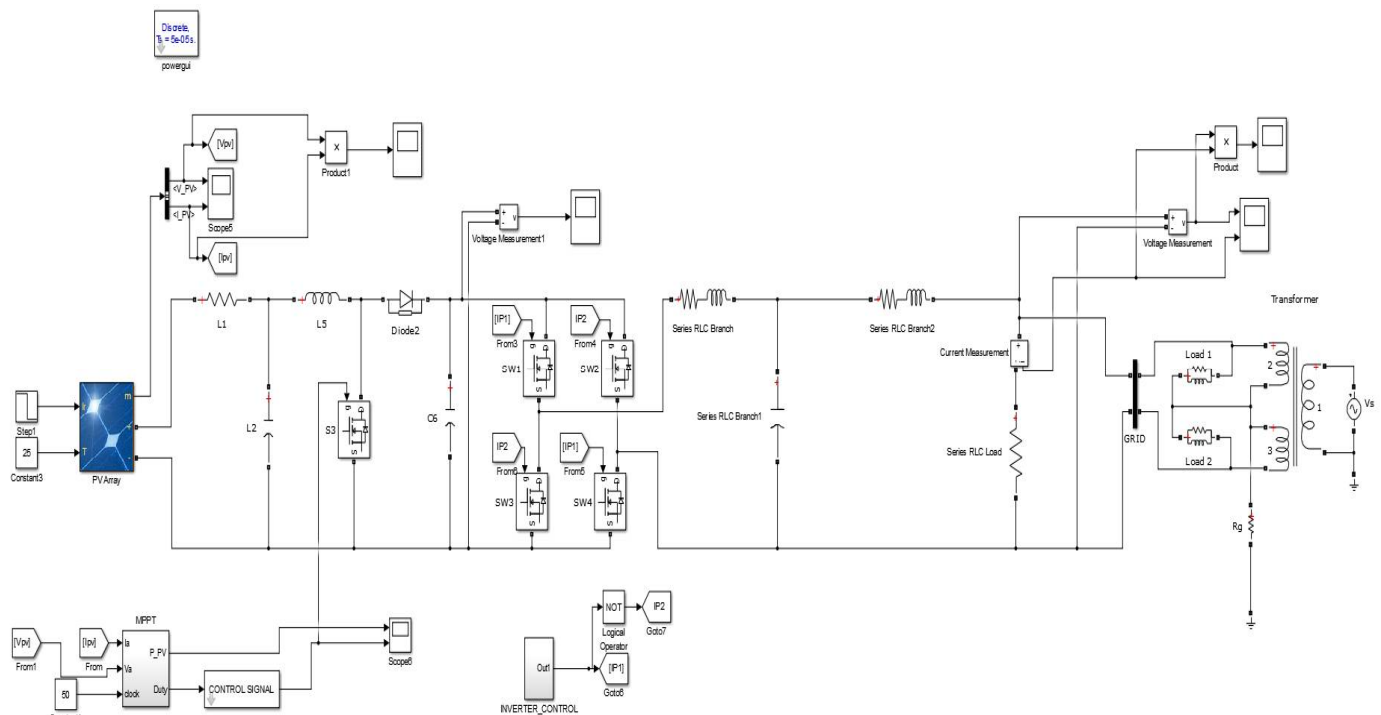

Fig. 8. ANN based MPPT circuit of solar photovoltaic cells

International Journal of Innovative Research in Science, Engineering and Technology

(A High Impact Factor, Monthly, Peer Reviewed Journal)

Visit: www.ijirset.com

Vol. 7, Issue 5, May 2018

IV. EXPERIMENTAL RESULTS

1. Current from PV array

The Fig. 9 shows the output current from the solar PV array which correspond to a value of 23.8 A. This current remains constant in the PV array.



Fig. 9. Photovoltaic array current

2. Voltage from PV array

The Fig. 10 shows an output voltage from the solar PV array which increases linearly till the halfway point. The maximum voltage observed in this plot is about 24.5 V which corresponds to value obtained from the Maximum Power Point tracking (MPPT).

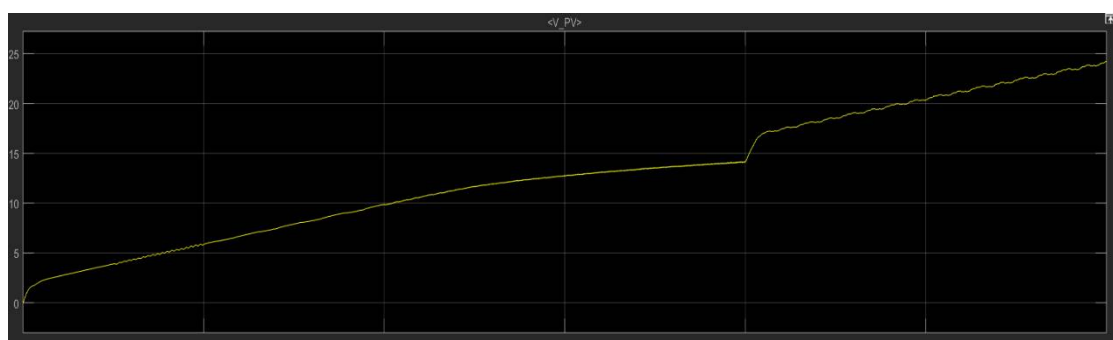

Fig. 10. Photovoltaic array voltage

3. Output Power from PV array

The Fig. 11 shows output power from the solar PV array which corresponds to 585 W using MPPT with certain input parameters.

International Journal of Innovative Research in Science, Engineering and Technology

(A High Impact Factor, Monthly, Peer Reviewed Journal)

Visit: www.ijirset.com

Vol. 7, Issue 5, May 2018

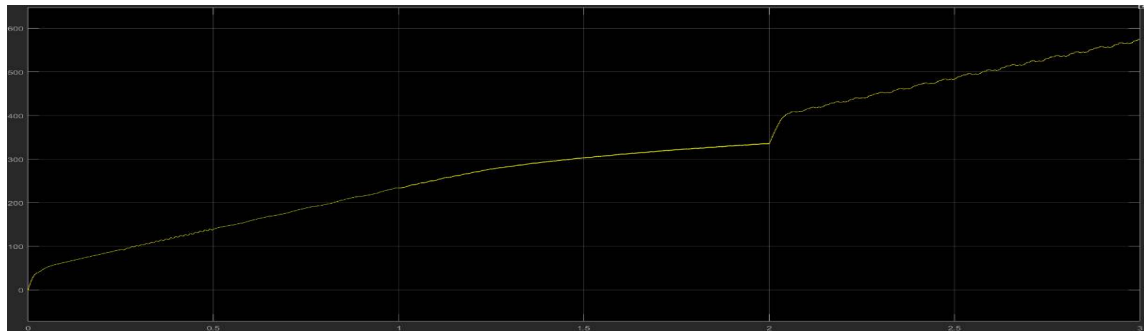

Fig. 11. Photovoltaic array power

4. Duty Cycle Generated by the MPPT controller

The Fig. 12 shows the duty cycle signal generated by the MPPT controller after implementing the P&O algorithm. When the switch is at '1', MOSFET turns 'ON' and when at '0', MOSFET turns 'OFF'.

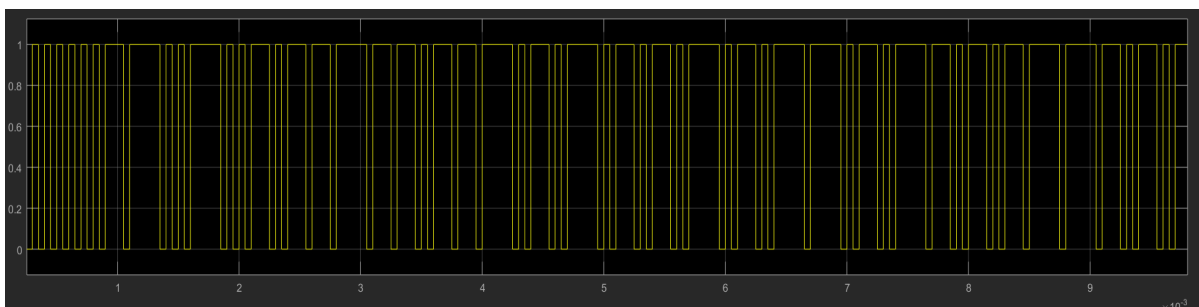

Fig. 12. MPPT Duty cycle

5. Voltage from DC-DC Boost Converter

The Fig. 13 shows the voltage received at the output boosted by the DC- DC buck boost converter from 24.5 V to 90 V in the converter.

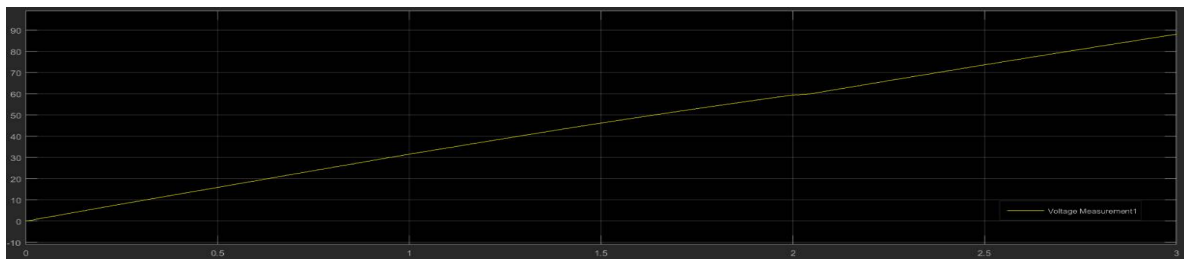

Fig. 13. Boosted Voltage

6. Duty Cycle generated by the ANN powered inverter control system

The Fig. 14 shows the duty cycle signal generated by the ANN circuit inside the inverter control system. This helps in switching the MOSFETs in the inverter. It produces positive or negative voltage depending on the switching cycle.

International Journal of Innovative Research in Science, Engineering and Technology

(A High Impact Factor, Monthly, Peer Reviewed Journal)

Visit: www.ijirset.com

Vol. 7, Issue 5, May 2018

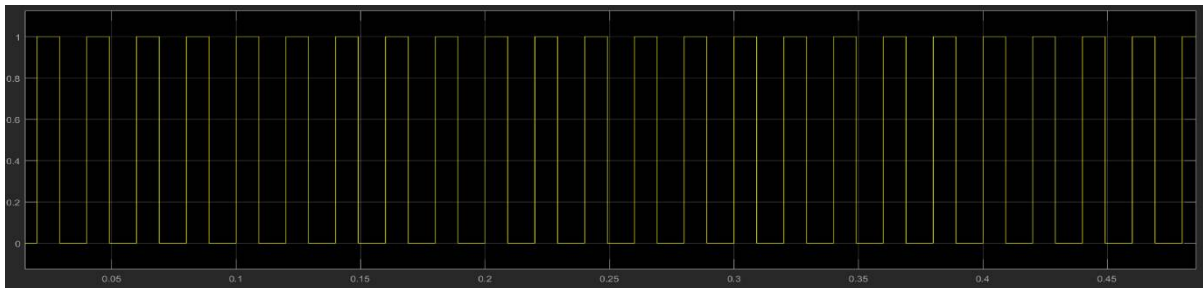

Fig. 14. Inverter control duty cycle

7. DC voltage before AC conversion

The Fig. 15 shows the DC voltage before being converted to an AC source by the inverter system. The DC voltage has an amplitude of 230 V which passes to the neural network block of the inverter system.

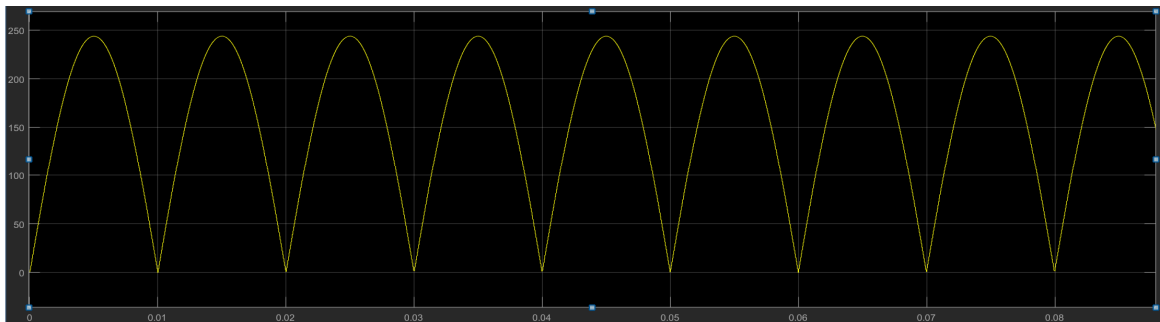

Fig. 15. DC voltage before conversion

8. AC Voltage to the grid

The Fig. 16 shows the AC output voltage after passing through the inverter control system and the RLC circuit. It is clear that the boosted DC voltage from the converter is transformed into an AC source by the inverter system and supplied to the grid.

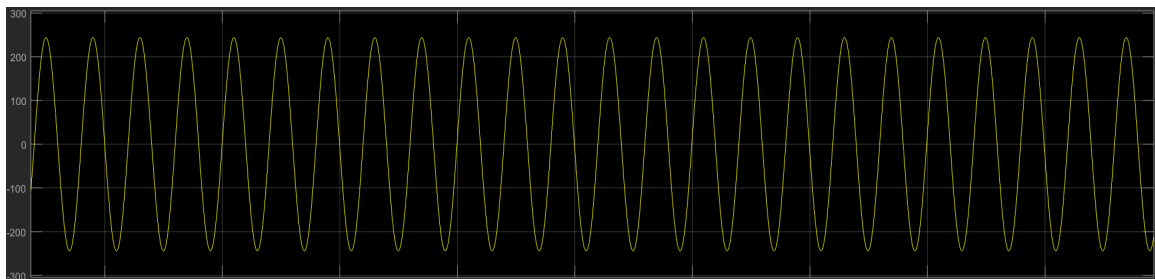

Fig. 16. AC grid voltage

International Journal of Innovative Research in Science, Engineering and Technology

(A High Impact Factor, Monthly, Peer Reviewed Journal)

Visit: www.ijirset.com

Vol. 7, Issue 5, May 2018

9. AC Current to the grid

The Fig. 17 shows the AC output current after passing through the inverter control system and the RLC circuit. It is evident that the current to the grid is reduced and the voltage has been increased for better transmission of power



Fig. 17. AC grid current

10. AC Power to the grid

The Fig. 18 shows the AC output voltage after passing through the inverter control system and the RLC circuit. We can see that the AC power generated after boosting and inverting is much higher than that of the solar PV array.

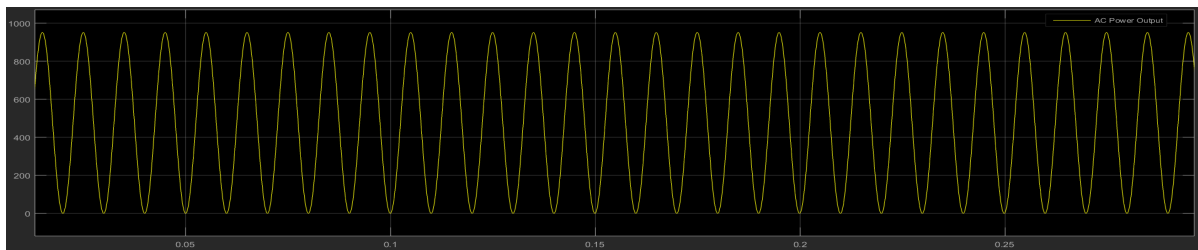

Fig. 18. AC grid power

V. CONCLUSION

Artificial neural networks are implemented in tracking maximum power point of solar cells. The implementation was successfully carried out and the accuracy in tracking the MPP under varying weather conditions was validated by the results. The low photovoltaic voltage was boosted to a higher level by the DC-DC boost converter and the inversion of the DC voltage to AC was performed using the H-bridge inverter. The distortions in the circuit due to various components is rectified using neural network setup. The AC voltage after inversion can be stepped up and transmitted to the grid for household purposes. The ANN based MPPT technique proves that it is the fastest and most robust method in tracking MPP and enables us to transmit power to the grid using transformers.

REFERENCES

- [1] Radwan, H. ; Abdelkarem, E. ; Ahmed, M. ; Orabi, M.;The non-ideality effect of optimizing the P&O MPPT algorithm for PV battery charger applications; Telecommunications Energy Conference (INTELEC), 2011 IEEE 33rd International; 2011.
- [2] Safari, A.; Mekhilef, S.; "Simulation and Hardware Implementation of Incremental Conductance MPPT With Direct Control Method Using Cuk Converter," Industrial Electronics, IEEE Transactions on , vol.58, no.4, pp.1154-1161, April 2011
- [3] Di Vincenzo, M.e.; Infield, D.; , "Artificial Neural Network for real time modelling of photovoltaic system under partial shading," Sustainable Energy Technologies (ICSET), 2010 IEEE International Conference on , vol., no., pp.1-5, 6-9 Dec. 2010

International Journal of Innovative Research in Science, Engineering and Technology

(A High Impact Factor, Monthly, Peer Reviewed Journal)

Visit: www.ijirset.com

Vol. 7, Issue 5, May 2018

- [4] R. Faranda, S. Leva and V. Maugeri, "MPPT Techniques for PV Systems: Energetic and Cost Comparison." in Proc. IEEE Power and Energy Soc. General Meeting, Pittsburgh, PA, July 21-24, 2008
- [5] Brian K. Perera, Phil Ciufo, SarathPerera, "Point of common coupling (PCC) voltage control of a grid-connected solar photovoltaic (PV) system" in Institute of Electrical & Electronics Engineers (IEEE), November 2013
- [6] W. T. Franke, C. Kürtz and F. W. Fuchs; Analysis of control strategies for a 3 phase 4 wire topology for transformer-less solar inverters, IEEE Int. Symp. Ind. Electron. Bari, pp. 658-663, 2010
- [7] Prof.P.S.Phutane, Prof.SurajR.Karpe; "Performance of a 4- switch, 3-phase inverter fed induction motor (IM) drive system"; Vol 2, Issue 3, 2013
- [8] J. H. R. Enslin, M. S. Wolf, D. B. Snyman, and W. Swiegers, "Integrated photovoltaic maximum power point tracking converter," IEEE Transactions on Industrial Electronics, vol. 44, no. 6, pp. 769-773, 1997.
- [9] Samangkool, K.; Premrudeepreechacham. S; "Maximum power point tracking using neural networks for grid-connected photovoltaic system," Future Power Systems, vol., no., pp.4 pp.-4, 18-18 Nov. 2005
- [10] M. Veerachary, T. Senjyu and K. Uezato, "Neural-network-based maximum-power-point tracking of coupled-inductor interleaved-boostconverter-supplied PV system using fuzzy controller," IEEE Trans. Ind. Electron., vol. 50, no. 4, pp. 749-758, Aug. 2003.
- [11] Syafaruddin, E. Karatepe and T. Hiyama, "Artificial neural network polar coordinated fuzzy controller based maximum power point tracking control under partially shaded conditions," IET Renewable Power Generation, vol. 3, no. 2, pp. 239-253, June 2009.
- [12] J. Lettl, J. Bauer, and L. Linhart, "Comparison of different filter types for grid connected inverter," in Proc. Progress in Electromagnetics Research Symp., Marrakesh, Morocco, 2011, pp. 1426-1429.