

## International Journal of Innovative Research in Science, Engineering and Technology

(A High Impact Factor, Monthly, Peer Reviewed Journal)

Visit: [www.ijirset.com](http://www.ijirset.com)

Vol. 7, Issue 5, May 2018

# Study on Performance of D-STATCOM Based Power Quality Enhancement in Distribution System

Sanghamitra Nath<sup>1</sup>, Dr Durgesh Prasad Bagarty<sup>2</sup>, Devidashinee Pradhan<sup>3</sup>, Deeptimayee Bhuyan<sup>4</sup>

P.G. Student, Department of Electrical Engineering, C.E.T, Bbsr, India<sup>1,3,4</sup>

Associate Professor, Department of Electrical Engineering, C.E.T, Bbsr, India<sup>2</sup>

**ABSTRACT:** Power quality is an important issue that is becoming increasingly important to electricity consumers at all levels of usage. It is a measure to provide a system supports for reliable operation for various loading condition. The intermittent switching of heavy nonlinear loads results in voltage sag, harmonics in distribution line and frequency variation. D-STATCOM is used to improve power quality of distribution system. Unit Template Algorithm is used for reference current generation which is a simple method for implementation and control. In this algorithm the control strategy, formations of unit vectors for inphase component and quadrature component is calculated for instantaneous value of voltage measurement at Pcc. The line parameter of 415 volt connected with linear loads are considered for analysis. The DSTATCOM model is done with MATLAB-SIMULATION software. Power quality improvement is analysed by comparing using controller and Unit Template algorithm with model without DSTATCOM.

**KEYWORDS:** Power Quality, D-STATCOM, Distribution Line, Unit Template Algorithm.

### I. INTRODUCTION

Power Quality is either voltage quality or current quality which is maintained sinusoidal within tolerance range. The growing complexity of the modern power systems is largely due to the day-to-day changes in the system configuration to meet the increasing demand of electrical energy, through the process of installation of new generating station, interconnection of the transmission lines, extra high voltage tie line etc. Some important issues for consideration in modern power system are

- Reactive power compensation
- Problems regarding stability of voltage (voltage fluctuations) and
- Harmonic effects due to sudden disturbances in the load.

Improved infrastructure is required for the existing power systems to facilitate effective utilization, superior control mechanism, reliability in operation and commercial profit. FACTS controllers are being extensively employed using advanced technology devices for effective utilization of the existing power system and for increasing power system's dynamic performance and stability. Here application of D-STATCOM for improvement in power quality is discussed.

- Two identified major power quality problems causing concern to customers are harmonics and voltage sags. Voltage sags is now focal issue, since the loads are voltage sensitive loads. It is the short duration voltage reduction due to load variation. The power industry can handle these challenges with the power electronics based technology of Flexible AC Transmission Systems (FACTS). FACTS have been defined by the IEEE as "Power electronics based system and other static equipment that provide control of one or more AC transmission system parameters to enhance controllability and increase power transfer capability". Among the FACTS controllers, the shunt controllers have shown feasibility in terms of their cost effectiveness to solve a wide range of transmission to distribution level problems. The

# International Journal of Innovative Research in Science, Engineering and Technology

(A High Impact Factor, Monthly, Peer Reviewed Journal)

Visit: [www.ijirset.com](http://www.ijirset.com)

Vol. 7, Issue 5, May 2018

distribution STATCOM (DSTATCOM) is similar to a STATCOM of a transmission system that uses a VSC of the required rating . However, the VSC used in a DSTATCOM is a six-pulse converter with SPWM or space vector modulated PWM (SVPWM) control over the magnitude of the injected AC voltage while maintaining a constant DC voltage across the capacitor. In the DSTATCOM, faster power semiconductor devices such as the IGBTs or IGCTs are used instead of the GTOs as in the STATCOM. The rapid switching capability provided by the IGBT (or IGCT) switches enables the use of DSTATCOM for balancing, active filtering and flicker mitigation. The unbalanced system is balanced by injecting a negative sequence current to the system. A DSTATCOM can be viewed as a controlled variable current source. The new voltage source converter topology is proposed for the DSTATCOM application. All the above problems can be solved by installing a DSTATCOM with proper controllers .In this paper DSTATCOM with Unit Template algorithm is considered as a controller to improve the power quality problem by reducing voltage sag.

## II.D-STATCOM

It is called distribution static synchronous compensator .It is a shunt connected device. It consists of a VSI and a DC storage capacitor for realization. DSTATCOMs are basically categorized into three types, namely, single-phase two-wire, three-phase three-wire, and three-phase four-wire configurations, to meet the requirements of three types of consumer loads on supply systems. A major amount of AC power is consumed by three-phase loads. A substantial work has been reported on three-phase three-wire DSTATCOMs

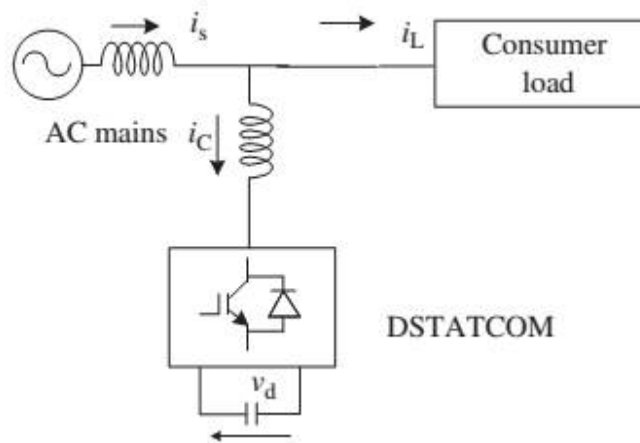

Fig-1 Schematic diagram of DSTATCOM

It has a self-supporting DC voltage bus with a large DC capacitor. It is more widely used because it is light, cheap, and expandable to multilevel and multistep versions, to enhance the performance with lower switching frequencies.

## III.CONTROL STRATEGY

The main objective of a control algorithm of DSTATCOMs is to estimate the reference currents using feedback signals. These reference currents along with corresponding sensed currents are used in PWM current controllers to derive PWM gating signals for switching devices (IGBTs) of the VSC used as a DSTATCOM. Reference currents for the control of DSTATCOMs have to be derived accordingly and these signals may be estimated using a number of control algorithms. Here we are using Unit Template algorithm with hysteresis controller to get reference current.

# International Journal of Innovative Research in Science, Engineering and Technology

(A High Impact Factor, Monthly, Peer Reviewed Journal)

Visit: [www.ijirset.com](http://www.ijirset.com)

Vol. 7, Issue 5, May 2018

## IV. UNIT TEMPLATE ALGORITHM

Calculation of source voltage amplitude

$$V_t = \sqrt{\left(\frac{2}{3}\right)(V_a^2 + V_b^2 + V_c^2)} \quad (1)$$

Calculation of in-phase template

$$U_a = \frac{V_a}{V_t}; U_b = \frac{V_b}{V_t}; U_c = \frac{V_c}{V_t}; (2)$$

Calculation of quadrature unit template

$$W_a = \frac{-U_b}{\sqrt{3}} + \frac{U_c}{\sqrt{3}}; W_b = \frac{\sqrt{3}}{2}U_a + \frac{U_b - U_c}{\sqrt{3}}; W_c = -\frac{\sqrt{3}}{2}U_a + \frac{U_b - U_c}{\sqrt{3}} \quad (3)$$

(3)

Instantaneous active and reactive powers of the loads are,

$$P_L = V_t(u_a i_{La} + u_b i_{Lb} + u_c i_{Lc})$$

$$Q_L = V_t(w_a i_{La} + w_b i_{Lb} + w_c i_{Lc}) \quad (4)$$

The instantaneous load power is composed of two components as DC component and AC component. DC component is to be filtered out using low pass filter.

$$p_L = \bar{p} + \tilde{p}; q_L = \bar{q} + \tilde{q} \quad (5)$$

For the computation of in-phase component of reference source current

Active power component of the source current  $I_{smp}^*$  and  $I_{smd}^*$  can be expressed as,

$$I_{smp}^* = \left(\frac{2}{3}\right)\frac{\bar{p}}{V_t} \quad (6)$$

$$I_{smd}^* = K_{pd}V_{dce} + K_{id} \int V_{dce} dt \quad (7)$$

Amplitude of active power component of the reference source current is given as,

$$I_{sm}^* = I_{smp}^* + I_{smd}^* \quad (8)$$

So for in-phase component of reference current we have to multiply  $I_{sm}^*$  with in-phase template.

$$I_{sad}^* = I_{sm}^* u_a; I_{sbd}^* = I_{sm}^* u_b; I_{scd}^* = I_{sm}^* u_c \quad (9)$$

(9)

B. For the computation of quadrature component of reference source current

Reactive power component of the source current  $I_{snq}^*$  and  $I_{sna}^*$  can be expressed as,

$$I_{snq}^* = \left(\frac{2}{3}\right)\frac{\bar{q}}{V_t} \quad (10)$$

$$I_{sna}^* = K_{pe}V_e + K_{ie} \int V_e dt \quad (11)$$

Amplitude of reactive power component of the reference source current is given as,

$$I_{sn}^* = I_{sna}^* - I_{snq}^* \quad (12)$$

So for quadrature-phase component of reference source current we have to multiply  $I_{sn}^*$  with quadrature -phase template.

$$I_{saq}^* = I_{sn}^* w_a; I_{sbq}^* = I_{sn}^* w_b; I_{scq}^* = I_{sn}^* w_c \quad (13)$$

C. For calculation of total reference source current

$$I_{sa}^* = I_{saq}^* + I_{sad}^* ;$$

$$I_{sb}^* = I_{sbq}^* + I_{sbd}^* ;$$

$$I_{sc}^* = I_{scq}^* + I_{scd}^* ; \quad (14)$$

# International Journal of Innovative Research in Science, Engineering and Technology

(A High Impact Factor, Monthly, Peer Reviewed Journal)

Visit: [www.ijirset.com](http://www.ijirset.com)

Vol. 7, Issue 5, May 2018

The reference source current  $I_{sa}^*, I_{sb}^*, I_{sc}^*$  is generated by summing the respective in-phase and the quadrature components of source current as shown in (8).

**Hysteresis Current Control**

To generate switching pulse for IGBT based VSC the actual source current is compared with reference source current in the hysteresis current controller. Carrier-less PWM hysteresis current controller is used for generating firing pulse of the gate drive of the IGBTs. The current errors are computed as, shown in (15).

$$I_{saerr} = I_{sa}^* - I_{sa};$$

$$I_{sberr} = I_{sb}^* - I_{sb};$$

$$I_{scerr} = I_{sc}^* - I_{sc}; \quad (15)$$

## V.SIMULATION AND RESULTS

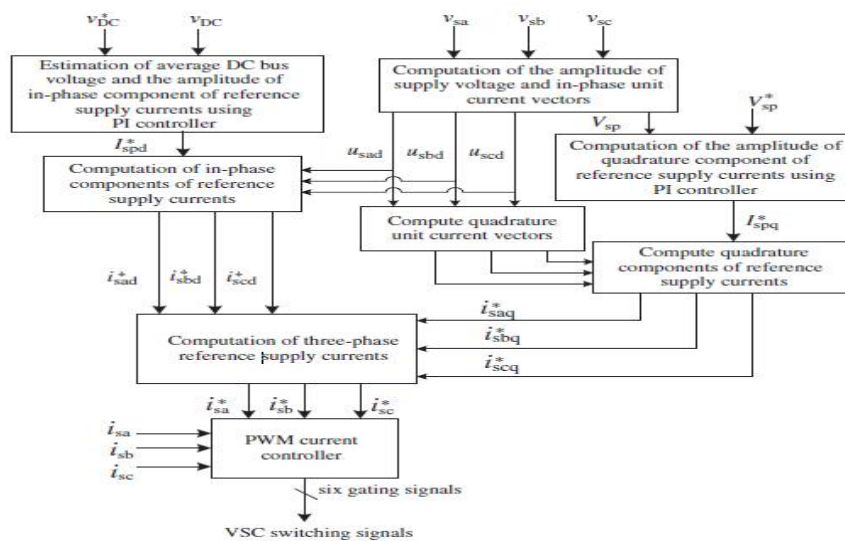

Fig 2. Block diagram of D-STSTCOM with unit template algorithm

# International Journal of Innovative Research in Science, Engineering and Technology

(A High Impact Factor, Monthly, Peer Reviewed Journal)

Visit: [www.ijirset.com](http://www.ijirset.com)

Vol. 7, Issue 5, May 2018

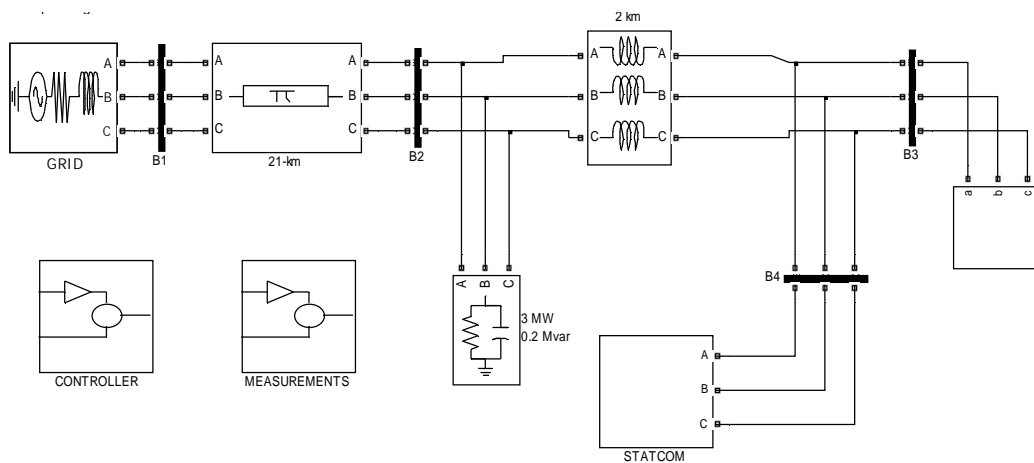

Fig 3. Simulation model of DSTATCOM

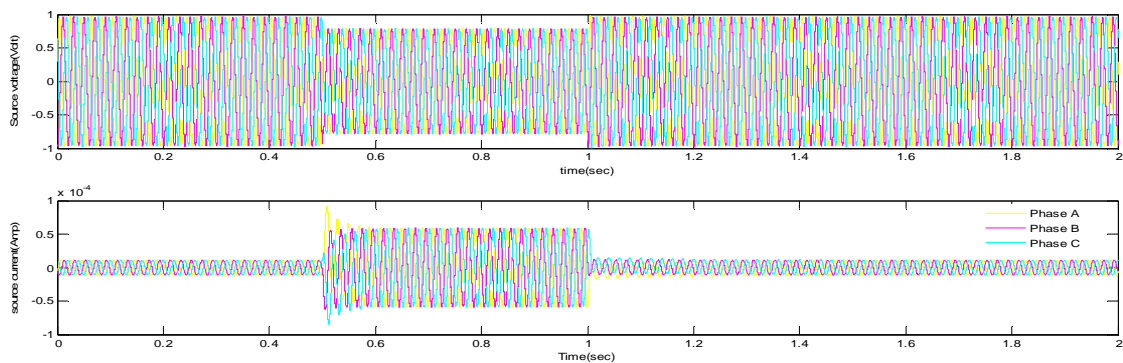

Fig 4. Load side voltage and current with using DSTATCOM with Unit Template algorithm

# International Journal of Innovative Research in Science, Engineering and Technology

(A High Impact Factor, Monthly, Peer Reviewed Journal)

Visit: [www.ijirset.com](http://www.ijirset.com)

Vol. 7, Issue 5, May 2018

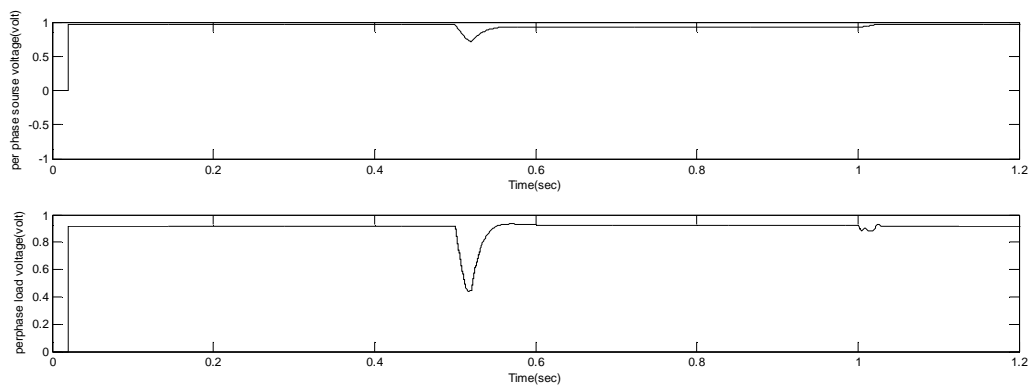

Fig 5. per phase source voltage and load voltage using DSTATCOM

## VI. CONCLUSION

The dynamic performance of the DSTATCOM under linear lagging power factor unbalanced load condition is. The DSTATCOM is switched on at .05 s. At 1 s, the load is changed to a two-phase load. The PCC voltages ( $V_s$ ), source currents ( $i_s$ ), load currents ( $i_L$ ), DC bus voltage ( $V_{DC}$ ), and amplitude of voltage ( $V_s$ ) at PCC are depicted in this figure. It is also observed that the DC bus voltage of the DSTATCOM is maintained close to the reference value under all disturbances. The amplitude of the PCC voltage is maintained at the reference value under various load disturbances, which shows the PFC mode of operation of the DSTATCOM. During .5-1s load is unbalanced but grid current is balanced. DSTATCOM provides extra reactive power during unbalance condition.

## REFERENCES

1. Mohammed Barghi Latran, , Ahmet Tek e and, Yeliz Yolda , "Mitigation of power quality problems using distribution static synchronous compensator: a comprehensive review" 2015.
2. Bhim Singh , P. Jayaprakash, D. P. Kothari , Ambrish Chandra and Kamal Al Hadad , "Comprehensive study of DSTATCOM configurations", IEEE Transaction 2014.
3. A. S. Alam, "A new fast algorithm to estimate real-time phasors using adaptive signal processing," IEEE Trans. Power Del., vol. 28, no. 2, pp. 807–815, Apr. 2013.
4. Bhimsingh and Jitendrasolank i, "A Comparison of Control Algorithms for DSTATCOM ", 2009.
5. Bhimsingh and Sushil k umar, " Modified Power Balance Theory For control of D-STATCOM" ,IEEE Conference, 2010
6. Mahesh K. Mishra, Arindam Ghosh and Avinash Joshi, "Operation Of D-STATCOM in Voltage Control Mode" IEEE Transaction, 2013.
7. Bhim Singh, Sabha Raj Arya, Ambrish Chandra and Kamal Al Haddad, "Implementation of adaptive filter in Distribution Static Compensator," IEEE Transaction 2013.
8. K. Bala Nikilesh and Nagshewara Rao, "Harmonic Compensation Using D-STATCOM in Combination with Renewable Energy Source to enhance Power Quality" IEEE Conference, 2015
9. H. Akagi, E. H. Watanabe, and M. Aredes, Instantaneous Power Theory and Applications to Power Conditioning. Hoboken, NJ, USA: Wiley, 2007.