

# An Efficient OFDMA Encoding and Decoding Scheme Using MIMO Architecture for Wireless Network Applications

V.Naveen Kumar<sup>1</sup>, Dr.T.Menakadevi<sup>2</sup>, V.Anitha<sup>3</sup>

PG Scholar, Department of ECE, Adhiyamaan College of Engineering, Hosur, TN, India <sup>1</sup>

Professor, Department of ECE, Adhiyamaan College of Engineering, Hosur, TN, India <sup>2</sup>

Ph.D Scholar, Department of ECE, Adhiyamaan College of Engineering, Hosur, TN, India <sup>3</sup>

**ABSTRACT:** OFDMA (Orthogonal Frequency Division Multiple Access) technique has been recently applied to wireless networks. CDMA (Code Division Multiple Access) is not suitable for designing a platform that requires computational power and flexibility at the same time. The proposed encoding and decoding method helps to hold the performance and cost of OFDMA Networks. The proposed system reduces the area and power consumption comparing to the existing system. In transmitter module, source data from different sender are independently encoded with an orthogonal code of a standard basis and these coded data are mixed together by an XOR operation. Then, the sum of data can be transmitted to their destinations through the wireless infrastructure. In the receiver module, a sequence of chips is retrieved by taking an AND operation between the sum of data and the corresponding orthogonal code. After a simple accumulation of these chips, original data can be reconstructed. MIMO detection system based on multi-core principles where the computation nodes are interconnected using the Network On Chip (NOC) model.

## I. INTRODUCTION

The Multi Input Multi Output (MIMO) technique has become a necessary ingredient in modem communication systems such as LTE/LTE-A and IEEE802.11n/ac [1], as it can improve the quality of wireless signal or data rate with the utilization of multiple antennas at the transmitter side either receiver side. MIMO technology is also widely used with Orthogonal Frequency Division Multiplexing (OFDM) modulation in contemporary wireless systems. Moreover, the system using large number of antennas, commonly known as the massive (or large-scale) MIMO system comes under the spotlight and draws interests both from theoretical and practical aspects[3].

Dr.T.Menakadevi *et al.*, [4 & 5] has designed and implemented a Direct Digital Synthesizer using CORDIC approach, to increase the speed with minimum area requirement in FPGA. COordinate Rotation DIgital Computer (CORDIC) algorithm is an interesting technique for phase to sine amplitude conversion which provides fast and area efficient computations of sine and cosine functions. Anitha.V *et al.*, [6] have designed VLSI Architecture of a Clock-gating Turbo Encoder for WSN applications. The proposed work is implemented using clock gating technique in order to reduce the power consumption. The architecture uses the fundamental Add Compare Select (ACS) operation. Due to the parallel processing operation of ACS blocks it has low processing steps, so that low transmission energy and less complexity about 71%.

An effective MIMO detection scheme to support large number of antennas, e.g., 16~16, 32~32, or even higher, become essential [8]. This drastically increases the demand for more computational power. Moreover, most previous work were targeting on one definite system setting with secure number of antennas and modulation scheme. As modern wireless applications are becoming more

dynamic and the system operates in various framework with different radio link conditions, quality or service requirements etc., there will be an increasing more flexible system configuration. Therefore, it is highly profitable to design and configurable.

MIMO detection system contains adequate computational power to support different modulation schemes and number of antennas, especially for the large number of antennas. Multi-core systems usually used dedicated point to point signal wires or shared buses to send communication data over the cores [11]. Such scheme has features of simplicity, easy to implement, and low-cost. However, multi-core systems with point to point interconnection scheme comes with a cost of lacking scalability and flexibility, especially when the number of cores increases and the amount of communication between the cores enlarges. As a result, it might not be suitable for designing a platform that requires computational power and flexibility at the same time.

To overcome this disadvantage, Network-on-chip has been proposed for data communication [12 & 13]. The NOC architecture consists of a number of Process Elements(PEs) connecting to a local Router(R) through a Network Interface Controller(NIC), where each Router is inter-connected to construct an on-chip network. Since different algorithms and applications can be realized using different numbers of PEs and different inter-connection topologies, the NOC structure has much better scalability and flexibility to support an application with versatile operation modes.

Since its debut, several works have been published designing particular applications on the NOC-based multi-core platform. To be specific, an optimized methodology for mapping embedded applications on NOC paradigm [14]. Realization of turbo decoder for wireless communications on the NOC-based multi-core systems are proposed by many authors [15]. This architecture is highly flexible and versatile to support various numbers of antennas and different modulation schemes. This paper is organized as follows. Reviews of the NOC-based multi-core system and detailed circuit architecture are given in Section 2 and Section 3. The proposed STBC Encoding/Decoding technique and Alamouti Scheme is presented in Section 4 and experimental results and discussion are illustrated in Section 5. Finally, this paper is concluded in Section 6.

## II. NOC-BASED MULTI-CORE SYSTEM

In a multi-core system, the cores (or Processing Elements, PEs) need to communicate with each other or to the external controller. This is traditionally done via the bus or cross-bar switches. However, such structures are lacking of flexibility or scalability and thus are not suitable for modern System On Chip (SOC) platforms. The architecture of NOC in mesh topology is presented in Fig.1.

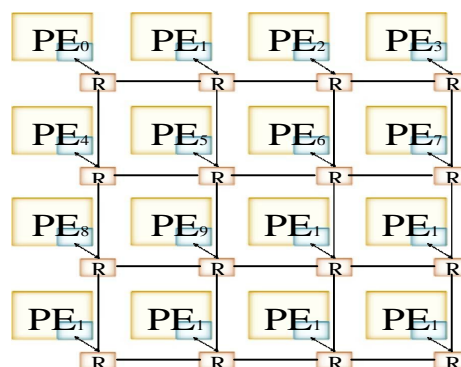

Fig.1 NOC architecture in Mesh topology

For instance, the throughput of a NOC-based multi-core system can be easily increased by adding more PEs onto the network, while the complexity can be quickly decreased by removing the PEs out of the network.

### III. DETAILED CIRCUIT ARCHITECTURES

The Processing Element (PE) is the core of the NOC structure. Through the inter-connection and interaction between the PEs, send them to the destination PE. When receiving packets from the source, the router examines the destination information and decides the next destination of the packets based on a specific routing algorithm. It describes simple XY routing algorithm, the router directs the packet to  $x$ -coordinate of destination first, followed by the  $y$ -coordinate.

In addition, the Network Interface Controller (NIC) is the agency between the PE and the router. The architecture of (a) the Detection Unit, (b) the sorter unit, and (c) the enumeration unit is presented in Fig.3.1. The packet transferred on network must go through NIC as it appends the needed network information with the packet. For example, the NIC adds data type and  $x$ -coordinate,  $y$ -coordinate when the XY routing algorithm is used. Furthermore, the packet sent to the PE is also passed by the NIC where it removes the network information.

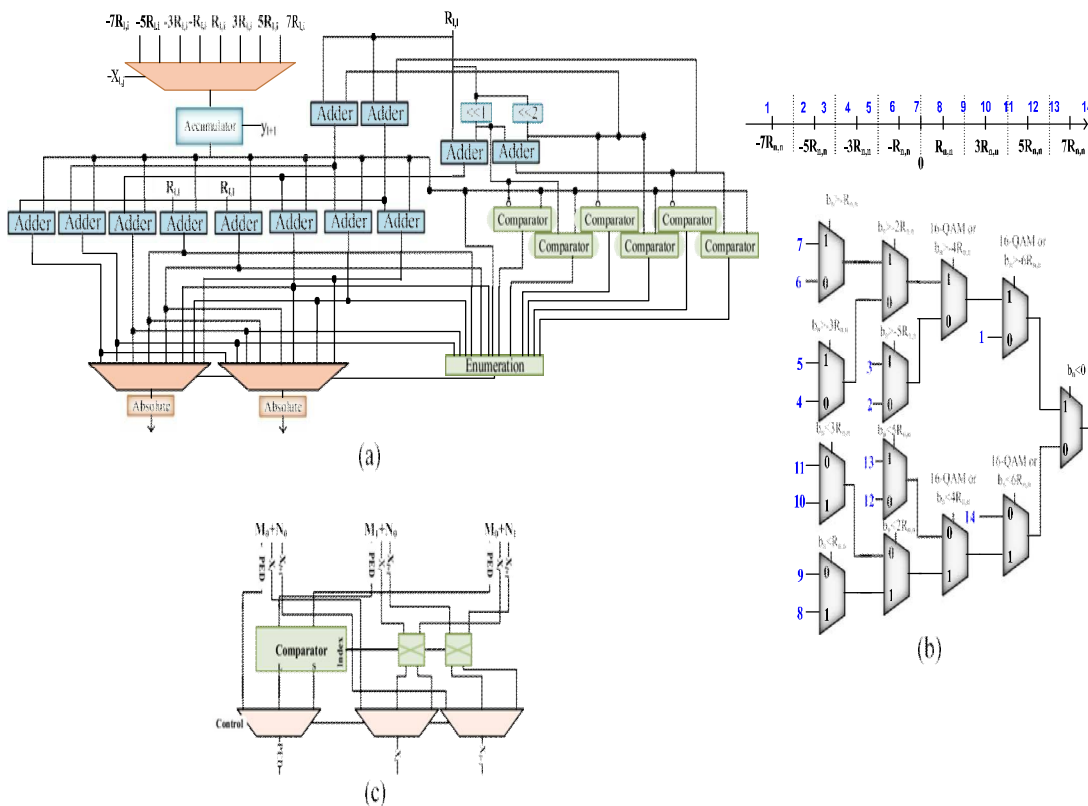

Fig.2 The architecture of (a) the Detection Unit, (b) the sorter unit, and (c) the enumeration unit

Detection Unit is the main processing engine to calculate the PEDs and storage elements are used for caching channel matrix elements,  $R$ , received signal elements,  $y$ , and information of the child nodes that are to be expanded in Fig 2(a).

Enumeration unit, in which the architecture controls two multiplexers based on the employed modulation scheme to select the best two symbols according to the result of comparators. The computed PEDs will then be sent to the sorter to determine the two or three best combinations.

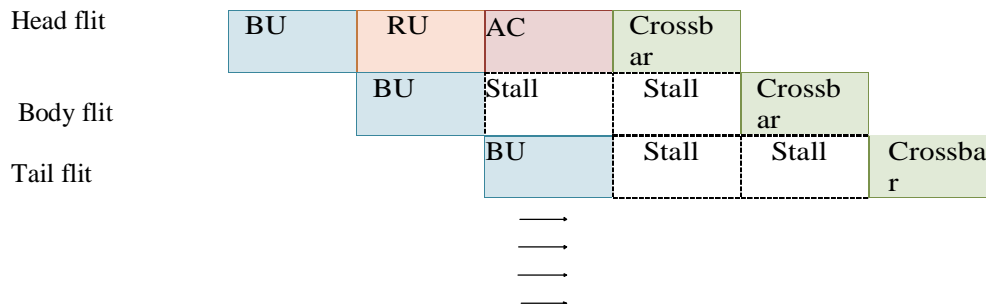

Fig.3 The typical pipelined operating for the router.

The body ‘flit’ and tail ‘flit’ all follow the route of head ‘flit’ and thus RU and AU keep their original state when receiving body ‘flit’ or tail ‘flit’. Therefore body ‘flit’ and tail ‘flit’ has two stall stages. Moreover, the information is carried by each type of the packets. The typical pipelined operating for the router is presented in above Fig.3.

It is comprised of Buffer Units (BUs), Routing Units (RUs), Arbitration Controller (ACs), and Crossbar with five input/output ports representing, north, east, south, west, and local PE respectively. In Fig 3, the typical pipelined operating for the router is presented. In this structure, five RUs are running in parallel and each of them is responsible for one input port, whereas the BU is a First In First Out (FIFO) buffer with size equal to one flit for the wormhole switching. All flits coming from other routers first go to the buffer waiting to be routed.

This router implements a simple XY routing algorithm, where the RU routes the packet to x-coordinate of destination first, followed by the y-coordinate. Furthermore, the AC consists of five arbiters where each of them is responsible for one output port. In Fig.3, architectural overview for a typical router is presented. Once received a request from one or more RUs for using the output port, the arbiter only grants one request and controls crossbar to connect corresponding direction BU to the output port.

**Architectural Design of proposed system**

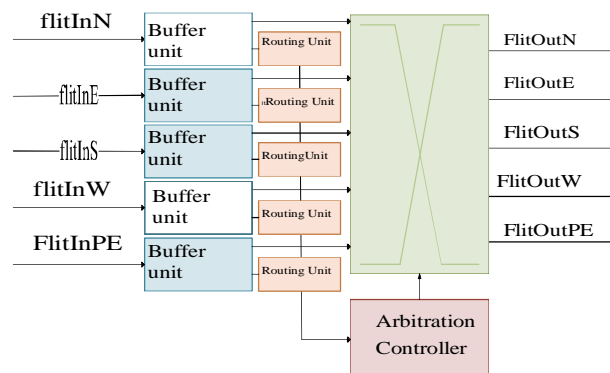

Fig.4 Architectural overview for a typical router.

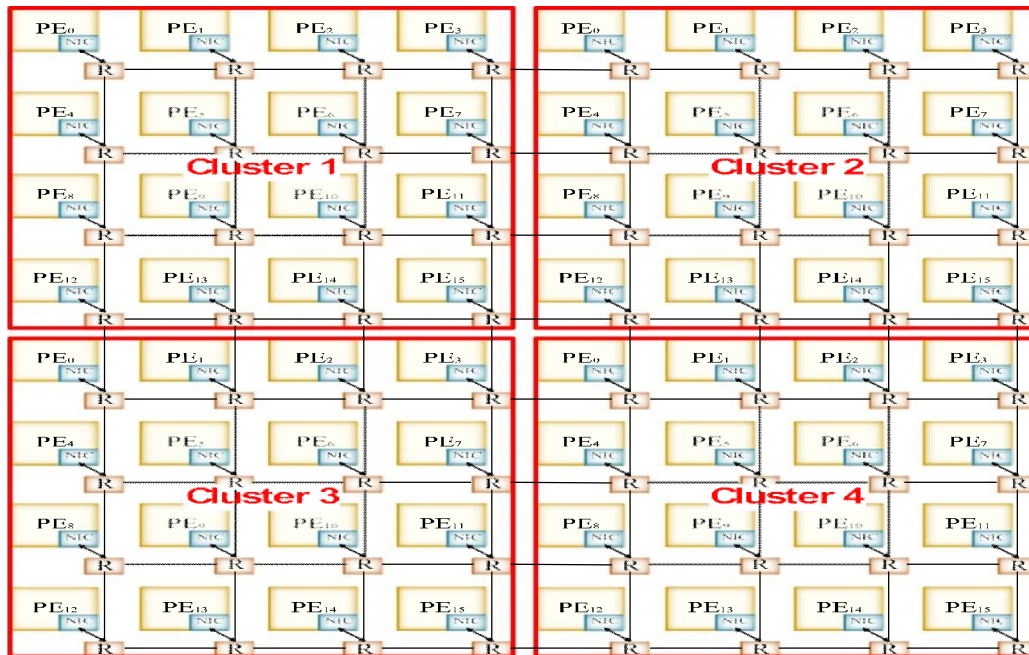

Fig.5 Proposed NOC architecture for MIMO-OFDM system

In this case, every 16 PEs are constructed as a cluster for processing one subcarrier. The number of subcarriers that can be processed at the same time depends on the number of clusters (and thus the number of PEs) in the system. In other words, the processing throughput of the entire system is related to the number of PEs in this multi-core system and leads to a design trade-off. More PEs can be instantiated when supporting a high-throughput application is desired, while less PEs are deployed when low area complexity and low power consumption are the major design goals. Proposed NOC architecture for MIMO-OFDM system is presented in above Fig.5.

In addition, a number of tree searching approaches have been proposed for realizing the near optimal MIMO detector. It is worth further researching on how to design and implement the NOC-based MIMO detector system.

#### IV. STBC ENCODING/DECODING

Space-time block codes (STBC) are a generalized form of Alamouti method, but have the same key property. These codes are orthogonal and can achieve full transmit diversity by the more number of transmit antennas. In further words, space-time block codes are a composite method of Alamouti space-time code, where the encoding and decoding method are the same as there in the Alamouti space-time code on both the transmitter and receiver sides.

At the receiver side, the signals received are first unified and then sent to the maximal likelihood detector where the determination rules are executed. Space-time block codes were produced to carry out the maximum diversity order for the given more number of transmit and receive antennas subject to the control of having a simple linear decoding method.

This has made space-time block codes a very distinguished and most widely used design. Training-based schemes seem to give very good results on the showing of channel estimation at the receiver. Pure training-based methods can be examined as an advantage when an exact and responsible MIMO channel needs to be received. Also, this could be a drawback when bandwidth efficiency is considered in part. This is because



pure training-based method to decrease the bandwidth efficiency considerably due to the use of a long training alignment which is certainly needed in order to reliable MIMO channel evaluate. Because of the computation complexity of blind and semi blind schemes, so many wireless communication devices still use pilot alignment to evaluate the channel parameters at the receiver side.

### 1. Alamouti Scheme

Alamouti strategy is the basic of the Space Time Coding method. The mathematical expression of this method containing two transmitter and one receiver antennas is also describe here. In this method, a two divide transmit diversity method is execute. Using two transmit antennas and one receive antenna, this method gives the same diversity arrangement as Maximal Ratio Receiver Combining (MRRC) with one transmit antenna and two receive antennas. This method may be generalized in to two transmitter and one receiver antennas to concede a diversity order of  $2M$ . At the transmitter side, block of two symbols is accepted from the source data and send to the modulator.

After that, Alamouti space time encoder accepts the two modulated symbols, in this sample called  $s_1$  and  $s_2$  produces encoding matrix  $S$  where the symbols  $s_1$  and  $s_2$  are denotes to two transmitter antennas in two transmit time slots.

### 2. STBC Encoding/Decoding method

The encoder and decoder block diagram of the Alamouti method system is given in Fig 6. Here the data to be transmitted is modulated and fed to the space time encoder. The space time encoder consists of two transmit antennas as part of the multiple input multiple output (MIMO) technology. So here the data is transmitted through two separate antennas. Each transmitting and the receiving antenna pair has a channel, represented by different channel coefficients. These channel coefficients play a major role in the design of the system. As the total number of antennas multiplies at both the sides of the channel, hence complexity of the system also increases drastically.

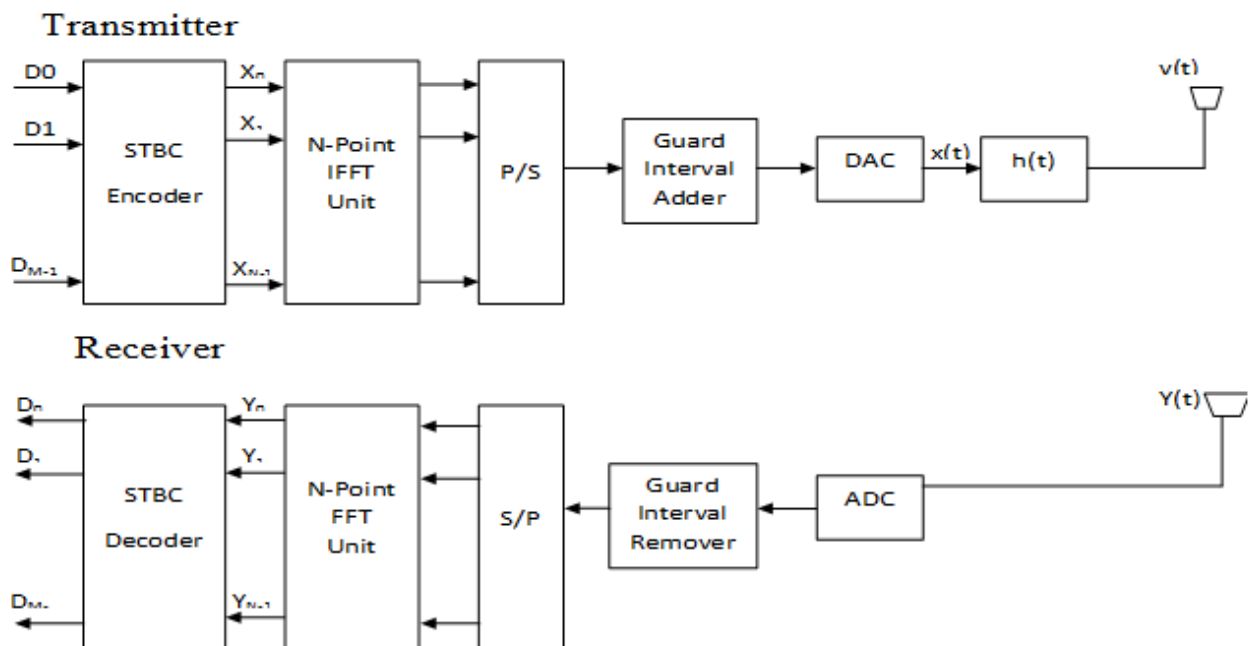

Fig.6 Block Diagram of OFDMA Transmitter and Receiver

$S[n]$  is a serial stream of binary digits. By inverse multiplexing, these are first de-multiplexed in to  $N$  parallel streams, and each one mapped to a (possibly complex) symbol stream using some modulation constellation (QAM, PSK, etc.). Note that the constellations may be different, so some streams may carry a higher bit-rate than others as given in Fig 6. From equation (1) and (2) the first and the second time slots of the received signals are analysed.

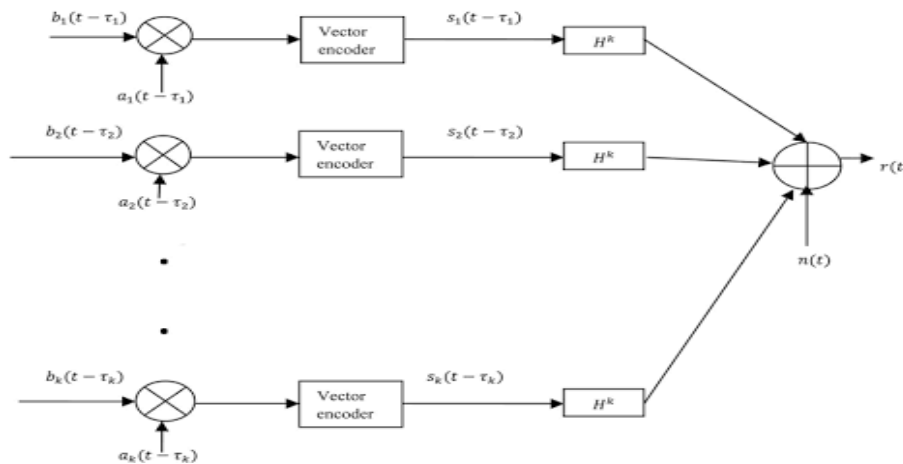

Fig.7 Block Diagram of OFDMA Encoding

In the first time slot, the received signal is,

$$y_1 = h_1x_1 + h_2x_2 + n_1 = [h_1 \ h_2] \begin{bmatrix} x_1 \\ x_2 \end{bmatrix} + n_1 \dots\dots\dots (1)$$

In the second time slot, the received signal is,

$$y_2 = -h_1x_2^* + h_2x_1^* + n_2 = [h_1 \ h_2] \begin{bmatrix} -x_2^* \\ x_1^* \end{bmatrix} + n_2 \dots\dots\dots (2)$$

### V. RESULTS AND DISCUSSION

Alamouti space time code is an orthogonal method that can carry out the full transmit diversity of  $N_t = 2$ . The bit-error-rate (BER) versus signal to noise ratio ( $E_b/N_o$ , dB) shows for Alamouti transmit diversity method on slow fading channels is estimates by simulation. In the simulation, it is assumed that the receiver has the perfect knowledge of the channel coefficient. It is also understand that the fading is mutually independent from each transmit antenna to each receive antenna and the total transmit power is the equal for all cases. Better results are generated by the system by using the more number of receiver antennas. This is due to the fact that as the total number of receiver antennas increases, the diversity of the system will increase. Higher diversity will give better presentation. So while calculating the STBC for a specific application, it need to select the more number of antennas at both sides of the communication link, the modulation and the rate of transmission. By using the correct STBC method, it is possible to improve the data rate and range of the wireless communication systems.

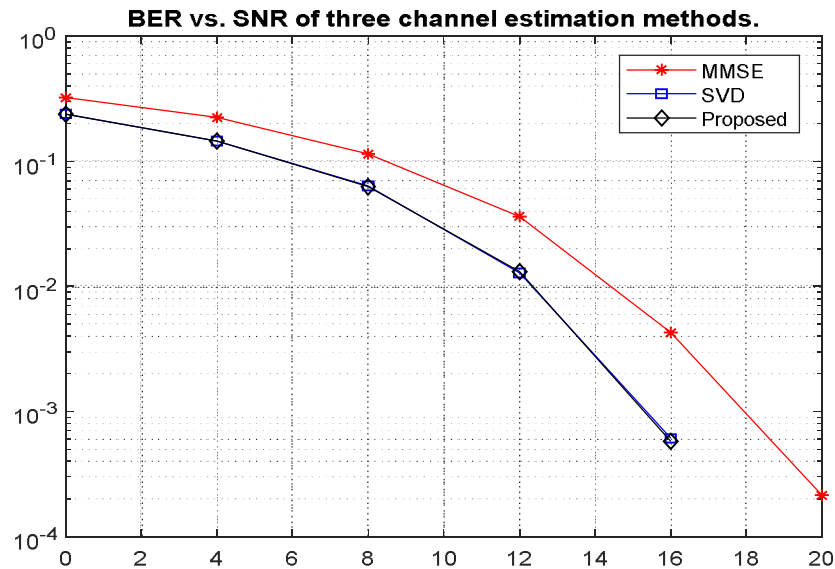

Fig.8 Response of BER Vs SNR

Table 1 describes,  $E_b/N_0$  must be used with care on interference limited channels since additive white noise (with constant noise density  $N_0$ ) is assumed, and interference is not always noise-like. In spread spectrum systems the interference is sufficiently noise-like that it can be represented as  $I_0$  and added to the thermal noise  $N_0$  to produce the overall ratio  $E_b/(N_0 + I_0)$ .

Table 1: BER (Bit Error Rate) Vs SNR (Signal to Noise Ratio)

Sl.no	BER	SNR(db)	MMSE	SVD	Proposed
1	0.0001	0	0	0	0
2	0.001	4	0.9	0.5	0.5
3	0.01	8	0.6	0.01	0.01
4	0.1	12	0.07	0.01	0.01
5	0.1	16	0.007	0.005	0.005
6	0.1	20	0.0009	0.0005	0.0005



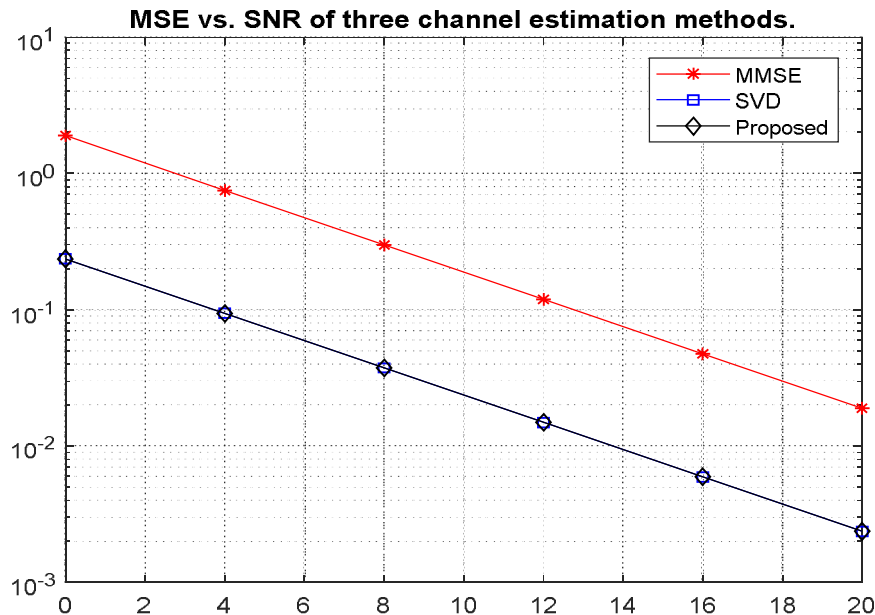

Fig.9 Response of MSE Vs SNR of three channel estimation methods

In Fig.9 it explains the response of MSE Vs SNR of three channel estimation methods. The performance of these two methods is compared by mathematical analysis and by simulation measuring Bit Error Rate (BER) and Mean Square Error (MSE) versus Signal to Noise Ratio (SNR). This result shows that, at higher SNR, the MMSE algorithm outperforms for both BER and SNR.

Table 2: MSE (Mean Square Error) Vs SNR (Signal to Noise Ratio)

Sl.no	MSE	SNR(db)	MMSE	SVD	Proposed
1	0.001	0	0	0	0
2	0.01	4	0.1	0.1	0.1
3	0.01	8	0.1	0.01	0.01
4	0.1	12	0.1	0.01	0.01
5	0	16	0.01	0.001	0.001
6	10	20	0.01	0.001	0.001

Table 2 describes, increasing the values of MSE and SNR, partially decreasing Singular Value Decomposition (SVD) values (i.e.,) compared to MMSE, proposed system gives a good results and less power consumption.

## VI. CONCLUSION

In this paper a basic preface to Space Time Coding has been provided by presenting Alamouti's method. In mobile technology, the Bit Error Rate (BER) and Signal to Noise Ratio (SNR) are very important parameters to be

considered. In this case, the proposed system achieves about 65% accuracy. From the results it is noted that the Signal to Noise Ratio (SNR) and Bit Error Rate (BER) is reduced up to 4db and 0.001 respectively. So the proposed algorithm tends to decide which modulation scheme and the combination of antennas is to be used by the communication link. The better BER curve is achieved by this system which uses more number of antennas at both sides of the communication link. This is due to the fact that as the number of receiver antennas increases, the diversity of the system will increase. Finally as a future expansion of this paper, it is possible to introduce different modulation schemes to increase the data rates. Also we can increase the number of antennas at both transmitter and receiver without introducing any interference in between the antennas.

## REFERENCES

- [1] E.G. Larsson, F. Tufvesson, O. Edfors, T.L. Marzetta, "Massive MIMO for nextgeneration wireless systems", IEEE Commun. Mag. 52 (2)186–195, 2014.
- [2] A.Burg, M.Borgmann, M.Wenk, M.Zellweger, W.Fichtner, H.Boleskei, "VLSI implementation of MIMO detection using the sphere decoding algorithm", IEEEJ. Solid State Circuits 40 1566–1577, 2005.
- [3] T.-H.Kim, I.-C.Park, "Small-area and low-energy K-best MIMO detector using relaxed tree expansion and early forwarding", IEEETrans.Circuits Syst.I: Regul. Pap. 57 (10) 2753–2761, 2010.
- [4] T.Menakadevi and M.Madheswaran, "Direct Digital Synthesizer using Pipelined CORDIC Algorithm for Software Defined Radio", International Journal of Science and Technology, Volume 2, June 2012.
- [5] M. Madheswaran and T. Menakadevi, "An Improved Direct Digital Synthesizer Using Hybrid Wave Pipelining and CORDIC algorithm for Software Defined Radio", Circuits, Systems, and Signal Processing, June 2013.
- [6] Anitha.V and Dr.T.Menakadevi, "VLSI Architecture of a Clock-gating Turbo Encoder for Wireless Sensor Network Applications", IJISSET - International Journal of Innovative Science, Engineering & Technology, Vol. 2 Issue 12, December 2015.
- [7] M.-T. Shiue, S.-S. Long, C.-K. Jao, S.-K. Lin, "Design and implementation of power-efficient K-best mimo detector for configurable antennas", IEEE Trans. VLSI Syst. 22 (11) 2418–2422, 2014.
- [8] F. Rusek, D. Persson, B.K. Lau, E.G. Larsson, T.L. Marzetta, E. O. F. Tufvesson, "Scaling up MIMO: opportunities and challenges with very large arrays", IEEE Signal Process. Mag. 30 (1)40–46, 2013.
- [9] M.Wu, S.Gupta, Y.Sun, J.R.Cavallaro, "AGPU implementation of a real-time MIMO detector", in: Proceedings of the IEEE Workshop on Signal Processing Systems, pp.303–308, 2009.
- [10] A.M.A.Hussien, R.Amin, A.M.Eltawil, J.Martin, "Energy aware mapping for re-configurable wireless MP SoCs", IEEE Trans. VLSI Syst. 23 (2) 392–396, 2015.
- [11] D.F. Macedo, D. Guedes, L.F.M. Vieira, M.A.M. Vieira, M. Nogueira, "Programmable networks from software-defined radio to software defined networking", IEEE Commun.Surv. Tutor. 17 (2) 1102–1125, 2ndquarter, 2015.
- [12] B.D. De Dinechin, D. van Amstel, M. Poulhies, G. Lager, "Time critical computing on a single-chip massively parallel processor, in: Proceedings of the Design", "Automation and Test in Europe Conference and Exhibition (DATE)"pp. 1–6, 2014.
- [13] E.Salminen, V.Lahtinen, K.Kuusilinna, T.Hamalainen, "Overview of bus-based system-on-chip interconnections, in: Proceedings of the IEEE International Symposium on CircuitsandSystem", vol.2, pp.372–375, 2002.
- [14] L. Benini, G. De Micheli, "Networks on chips: a new SoC paradigm", IEEE Com-, 2002.
- [15] C.Nicopoulos, V.Narayanan, C.R.Das, "A Baseline NoC Architecture in Network"-, 2010.
- [16] G.Jiang, Z.Li, F.Wang,S.Wei,"Mapping of embedded applications on hybrid networks-on-chip with multiple switching mechanisms", IEEE Embed. Syst., 2015
- [17] Q. Yang, X. Zhou, G.E. Sobelman, X. Li, "Network-on-chip for turbo decoders", IEEE Trans. VLSI Syst.2015.