

Automatic Room Temperature and Monitoring System Using Arduino

Swetha S¹, Ilakkiya SN², Nevetha R³, Sarathy S⁴, Deepa R⁵

M. E Embedded System, Bannari Amman Institute of Technology, Erode, Tamil Nadu, India^{1 2 3 4}

Asst. Professor, Bannari Amman Institute of Technology, Erode, Tamil Nadu, India⁵

ABSTRACT: This paper deals with the “Automatic room temperature control and monitoring system using arduino”. In this proposed system the room temperature is maintained constantly. According to the value set by the user the heater and Ac turned on or off. The system will get the temperature from the DHT11 temperature sensor. The DHT11 temperature sensor measures both the temperature and humidity The value of temperature and humidity is displayed in Liquid Crystal Display (LCD). The entire system was controlled by the Arduino Microcontroller. The Microcontroller senses the temperature and it compares the data value set by the user. The controller turns on the AC when the current temperature is greater than the set data temperature and the controller turns on the heater when the current temperature is lower than the set temperature.

KEYWORDS: Arduino, Room temperature, LCD.

I. INTRODUCTION

In modern days, many intelligent technologies are introduced in our environment. In the smart electronic world microcontroller plays an important role in the development of smart system. New technologies are developed day by day, in this many technologies microcontrollers act as the heart of the system. These microcontroller consist of single chip processor it is suitable for the automation and control process and also it gives the accurate results. Now a days maintaining a room temperature in home and offices has been an increasing problem. In order to solve the problem the controlling of temperature becomes a solution for this arising problem. Controlling of temperature is a process, in which the temperature of the space or object is changed. This paper describes the maintaining of constant room temperature and also enables the automatic cooling and heating system according to the room temperature. The design and implementation of system was done by arduino hardware and the program is written in arduino IDE and it displays the temperature in LCD. According to the temperature change it enables the cooling and heating system by AC and heater.

II. LITERATURE REVIEW

Joseph chuma and Bokamoso Basulti has proposed the system of design and simulate the controlling of room temperature using pic microcontroller. This system was mainly useful for the people who are disabled. In this system the temperature was measured by the LM35 temperature sensor and the temperature displayed in a LCD display. The temperature value senses the PIC16F877A controller. According to the temperature changes the fan gets on or off. The temperature value is higher than the reference value the fan gets on and the temperature value is lower than the reference value the fan gets off. The reference value is entered by using keypad. Relay is used for the switching purpose. Software proteus 8 is used for simulating the result[1].

M.Kumaran, and I.Vikramhas proposed the system of automatic fan speed control using arduino uno. The process of the system is controlled by the arduino uno controller. The temperature is measured by the LM35 temperature sensor. Potentiometer is act as the regulator is connected to the microcontroller. The fan speed is controlled by the

International Journal of Innovative Research in Science, Engineering and Technology

(A High Impact Factor, Monthly, Peer Reviewed Journal)

Visit: www.ijirset.com

Vol. 8, Issue 4, April 2019

potentiometer. Depending on the variation in the temperature the speed of the fan is on or off. The fan speed is measured manually and the speed of the fan and temperature is displayed in the LCD display. The fan speed was displayed in the Revolution Per Minute(RPM). Temperature changes, and the RPM fan speed changes occurs[2].

Suraj kausik and yuvraj singh chouhan has proposed a system on fan speed controlling system using temperature and humidity sensor. The controller used in this system is arduino microcontroller. According to the environmental temperature the fan speed is manually controlled. The temperature and humidity is measured by DHT22 Sensor and displayed in the LCD. The duty cycle of the temperature is already set as the reference temperature. The values of the duty cycle changes the fan speed also varies on the temperature change. The fan speed is controlled by the Pulse Width Modulation (PWM). PWM controls the fan speed with respect to the sensed temperature [3]

E.Harshavardhan Goud and A.Harshika has proposed a temperature controlled system using arduino. It is a real time implementation project. LM35 temperature sensor is used to measure the temperature as the appropriate voltage. This voltage is given to the arduino. The temperature value is displayed in the 16x2 LCD display in both Fahrenheit and centigrade unit. The controller sends the data to the relay. Relay is act as the switching device. The temperature become beyond the level of data set by the user the relay gets triggered and activate. Than the relay switches the cooling device. In this way it controls and monitors the temperature control [4].

Kunal singh and Moloy Dhar has proposed a system fan speed controlling system using arduino it is an automatic process. The system is mainly based on the home automation. The fan speed is controlled for maintaining the constant room temperature. The value of the temperature measured by the LM35 temperature sensor. The relay is used as a switching device. Data for the analysis was already set by the user. The microcontroller analyze the value of the data. The fan speed will automatically increases when the room temperature is beyond the level of set data temperature. The temperature becomes lower the fan speed get reduced. According to the temperature the fan speed will get changed [5].

M.A.A Mashud and Dilruba Yasmin has proposed a system of controled the room temperature of fan speed controller using PT-100. The used temperature sensor is PT100 it converts the temperature into equivalent voltage. The controlling of fan speed is done by the many system analysis. According to the systematic analysis the performance of the device was obtained as a satisfactory. The systematic design of low power supply, fixed voltage, subtraction and dimmer unit are designed and the comparison among the one another devices was taken as the graphical representation. Through that the results was taken and the temperature was controlled [6].

A.L.Amoo and T.L.G.Soh has proposed the system of implementing and designing the room temperature controlling system. They have used Pic microcontroller as a controlling device. The temperature is measured by using LM35 temperature sensor. Thepic microcontroller was programmed using MPLAB IDE. The input is given by the keypad it gives the desired temperature value. The reference input is compared with the temperature. The controller gives the output to the relay. It switches the AC and heater via opto-coupler according to the increases and decreases of the temperature value. The simulation of the result is done by the MATLAB software[7].

Vaibhav Bhatia and Gavish Bhatia has proposed fan speed controlled system based on the room temperature. It is mainly depends on the Pulse Width Modulation technique. PIC Microcontroller is used as the controlling device. The temperature is measured by the LM35 Temperature sensor. Crystal oscillator and motor driver is used in this proposed system. The crystal oscillator is used to give the clock signal and the motor driver is used to control the motors. The pic

International Journal of Innovative Research in Science, Engineering and Technology

(A High Impact Factor, Monthly, Peer Reviewed Journal)

Visit: www.ijirset.com

Vol. 8, Issue 4, April 2019

microcontroller controls the entire operation. According to the duty cycle set by the user the fan speed become slow, medium, fast, very fast and stops. The simulation of the process is done by the proteus software [8].

Zairi Ismael Rizman and Kim Ho Heap proposed a system automatic temperature control system for electric fan using PIC microcontroller. The temperature is measured by the LM35 temperature sensor. The temperature value is displayed in the LCD display. The temperature increases beyond the set value of the reference temperature the fan gets on. The temperature decreases beyond the set value of the reference temperature the fan gets off. It is an automatic process. The result is simulated by using the software [9].

Mustafa saad and Hossam Abdoalgade has proposed a system on automatic room temperature controlled system using PIC microcontroller. The temperature value is measured by the LM35 temperature sensor. The value is displayed in a LCD display. The duty cycle of temperature was already set by the user. The temperature value decreases the fan speed will reduces and the temperature value increases the fan speed increases. The entire system was controlled by the pic controller [10].

III. PROPOSED SYSTEM

The proposed system consist of Automatic room temperature control and monitoring system using arduino. The proposed system consist of block diagram is explained below.

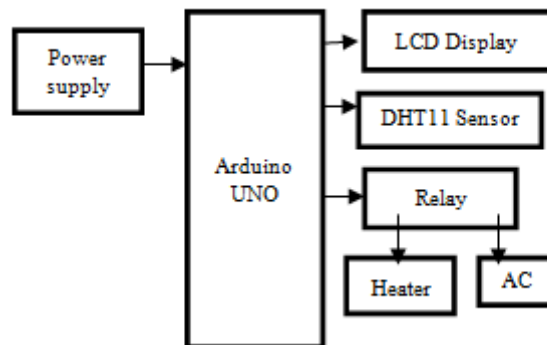

Fig 1. Block diagram of room temperature and monitoring system

3.1 COMPONENT DISCRIPTION

3.1.1 ARDUINO UNO

Arduino is the microcontroller based kit. It was the main memory of the systems. It consist of both hardware and software device. Physical programmable circuit board has hardware and IDE has software the runs on the computer and it is used to write and upload our computer code to the physical code. Auduino consist of 14 digital input pins, 6 analog pins, USB connection, DC Voltage supply, power indication, voltage regulator and reset button. Auduino is used to read the input like lighting on a sensor and turn on to output like turning on the LED and activating the motor etc. all the devices are interfaced through the arduino and the decision was taken by the arduino. It consists of boot loader so we can directly load the program to the device. Operating speed of the arduino is 5v. It is inexpensive, open source

International Journal of Innovative Research in Science, Engineering and Technology

(A High Impact Factor, Monthly, Peer Reviewed Journal)

Visit: www.ijirset.com

Vol. 8, Issue 4, April 2019

hardware and software and also the arduino software is compatible with all the type of operating system like Windows Linux.

3.1.2 LCD DISPLAY

Liquid Crystal Display is used for purpose of displaying the temperature and humidity value. It is an electronic display module. 16x2 and 20x2 are the most commonly used LCDs. 16x2 LED means it displays 16 character of column's and 2 character of rows as same as 20x2. The displaying character has pixel of 5x4 matrix. The LCD consist of two registers one is command another one is data. The reason for choosing the LED is, it is easily programmable, economical, and it has a no limitation for displaying the character.

3.1.3 DHT11 SENSOR

DHT11 Sensor is used to measure the temperature and humidity. It produces a digital output signal. It consist of four pin. 1st pin is connected to the vcc on the power supply 3.5 to 5 V. 2nd pin is connencted to the data. 3rd pin has no connection. 4th pin is connected to the ground. The sensor is interface with Arduino and produces an output. For the humidity measurement it consist of sensing component and IC at the back side. It consist of two electrode if any resistance changes occurs between these electrodes, the changes are processed by sensing IC and then the microcontroller reads the value. Negative temperature coefficient sensor are used for temperature measurement.

3.1.4 RELAY

Two channel optocoupler relay are used. It is an electrically controlled device and activates the other devices according to the same electronic circuit. Depends on the power dissipation and the electrical characteristic the size of the relays are designed. The relay is used as the switches to activate the devices depends on the character.

3.1.5 HEATER

The heater is an electronic device. It is used to make the room heat. By the adjustment of the voltage the heater varies. The room temperature decreases the heater automatically switched on by the relay.

3.1.6 AIR CONDITIONER

The air-conditioner is used when the climate becomes too hot. It takes heat from the environment and convert the high pressure gas into low pressure liquid. The liquids are passes through the condenser and compressor, the conversion of low pressure liquid to low pressure gas. The value of the gas and liquid are measured through the metering scale. The conversion of process takes place in a continuous manner.

3.2 EXPLANATION

The arduino microcontroller is used as the main process controlling unit in the controlling of the room temperature. Operating voltage is given to the system is 5v. Temperature and Humidity is measured by the DHT11 temperature sensor. The measured value of the temperature and humidity is displayed in the Liquid Crystal Display. In this system relay is using as the switching element to activate the devices according to the temperature changes. The data of temperature is already set by the user. If the temperature goes below the reference level of the user set temperature the relays activates the heater to on. The temperature goes lower than the reference level of the user set temperature the relay activate the air conditioner to make it on. The relays switches the device based on the temperature change.

International Journal of Innovative Research in Science, Engineering and Technology

(A High Impact Factor, Monthly, Peer Reviewed Journal)

Visit: www.ijirset.com

Vol. 8, Issue 4, April 2019

IV. EXPERIMENTAL RESULT

DHT11 sensor sense the temperature and humidity, The AC gets ON when the temperature is above 31degree Celsius. Current temperature and the humidity are viewed in the LCD display. The AC gets ON because of the sensed temperature is above the fixed temperature, if the temperature gets lower than the fixed temperature heater will get ON, the switching function is done by 2 channel optocoupler relay that we used in the project.

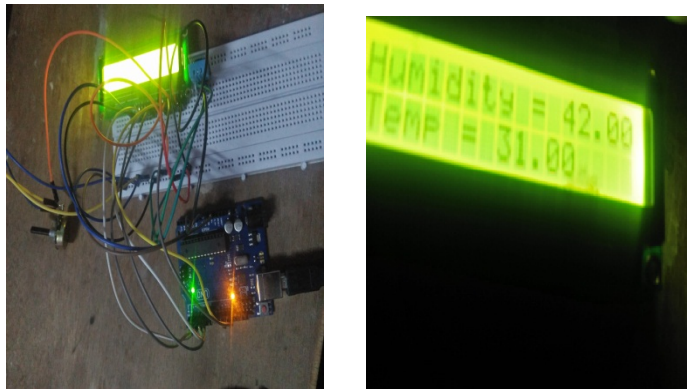

Fig 2. Experimental setup and result

V. CONCLUSION

In this project, the room temperature is maintained and monitored continuously by using the dht11 temperature and humidity sensor with arduino. This project helps to keep the people always in comfort zone and it also helps the people to know the current temperature and humidity in the LCD display.

REFERENCES

- [1].Mustafa saad and HossamAbdoalgade, Automatic fan speed control system using microcontroller, International Conference on Electrical Electronic and Civil Engineering, November 2013.
- [2]Zairi Ismael Rizmam, Design an Automatic Temperature Control System for Smart Electric Fan Using PIC, International Journal of Science and Research(IJSR), Volume 2, Issue 9, September 2013.
- [3]. Vaibhav Bhatia, Room Temperature based Fan Speed Control system using Pulse Width Modulation Technique, International Journal of Computer Applications, Volume 85- No 5, November 2014.
- [4]. A.L.Amoo, Design and Implementation of a Room Temperature Control System: Microcontroller- Based, IEEE, 2014.
- [5]. DilrubaYamin, Automatic Room Temperature Controlled Fan Speed Controller Using PT-100, International Journal of Scientific and Engineering Research, Volume 6, Issue 8, August 2015.
- [6]. Kunalsingh, Automatic Fan Speed Control System using Arduino, International Journal of Novel Research and Development, Volume 2, Issue 4, April 2017.
- [7]. E.HarshavarthanGoud, Real Time Based Temperature control Using Arduino, International Journal of Innovations in Engineering and Technology, Volume 8, Issue, April 2017.
- [8]. Surajkaushik, Automatic Fan Speed Control using Temperature and Humidity Sensor and Arduino, International Journal of Advance Research, Ideas and Innovations In Technology, Volume 2, Issue 8, 2018.
- [9]. M.Kumaran, Design of an Automatic Fan Speed Controlling System using Arduino UNO, International Journal of Intellectual Advancements and Research in Engineering Computations , Volume 6, Issue 2, 2018.
- [10]. Joseph chuma, Design and Simulation of an Automatic Room Heater Control System, BostwanaInternational University of Science and Technology, 2018.