

International Journal of Innovative Research in Science, Engineering and Technology

(A High Impact Factor, Monthly, Peer Reviewed Journal)

Visit: www.ijirset.com

Vol. 8, Issue 4, April 2019

Design and Analysis of Low Power Application Based Median Filter Using Full Adder Cell

N.Bhuvaneshwari¹, P.Padmaloshani², Dr. G. Selvakumar³

Research Scholar, Department of Electronics and Communication Engineering, Muthayammal Engineering College,
Tamilnadu, India¹

Associate Professor, Department of Electronics and Communication Engineering, Muthayammal Engineering College,
Tamilnadu, India²

Dean, Department of Electronics and Communication Engineering, Muthayammal Engineering College,
Tamilnadu, India³

ABSTRACT: In this system design and analysis of low power application based median filter using full adder is proposed. The Carry Save Array (CSA) multiplier is designed by using the proposed adder cell based on multiplexing logic. The median filter technique can be implement using this carry save array multiplier to remove the noises at low power and delay. Using complementary pass transistors logic (CPL) the area of full adder also reduced. The multiplier circuits are schematized and their layouts are generated by using Microwind software. Thus the full adder circuit based multiplier circuits gives better performance than other published results in terms of power dissipation and area due to less number of transistors used in adder circuit.

KEYWORDS: Structure of FIR Filter, Grouping flow for Canonic Signed Digit(CSD) Coefficients, Microwind MOS Layout, Carry Save Array (CSA) multiplier, Full adder cell, CPL .

I. INTRODUCTION

Low power design is necessary to extend the operating time of integrated circuits (ICs) as well as to reduce the packaging and cooling costs. As the scale of integration keeps growing, more and more complex signal processing systems are being implemented on a VLSI chip. These signal processing applications consume considerable amount of energy. The trade-off of performance and area remain to be the two major design factors, high power consumption is critical in today's VLSI system design. The need for low power VLSI system arises from two main forces. First, Static power dissipation is due to the leakage current. Second, Dynamic power dissipation is due to the transition activity that dominates the total energy dissipation due to charging and discharging of capacitors. Multiplication is a fundamental operation in most signal processing algorithms. Multipliers have large area, long latency and consume considerable power. Therefore low-power multiplier design has been an important part in low- power VLSI system design.

Filter is a frequency particular system. It passes a band of frequencies while constricting the others. Channels are delegated simple and computerized relying upon nature of sources of info and yields. Channels are additionally delegated limited motivation reaction and endless drive reaction channels relying upon motivation reaction. This part gives a brief about the sorts of channels. Advanced channels are utilized broadly in every aspect of electronic industry. This is on account of advanced channels can possibly accomplish much preferable flag to commotion proportions over simple channels and at each middle of the road arrange the simple channel adds more clamor to the flag, the computerized channel performs quiet scientific operations at each moderate stride in the change.

International Journal of Innovative Research in Science, Engineering and Technology

(A High Impact Factor, Monthly, Peer Reviewed Journal)

Visit: www.ijirset.com

Vol. 8, Issue 4, April 2019

II. RELATED WORK

Finite impulse response (FIR) filters are used in Digital Signal Processing applications. Accuracy in filter Designing is based on the Multiplication and accumulation of filter coefficients. Filters are digital filter whose response to the unit filter (Unit Sample Function) is finite in duration. This is in contrast to Infinite impulse response (IIR) filters whose response to unit impulse is infinite in duration FIR filter can be implemented using either recursive or non-recursive techniques, but usually non recursive technique are used. FIR filter is Finite IR filter and IIR filter is Infinite IR filter. FIR filters are non-recursive. The structure of FIR filter is shown in the figure 1.

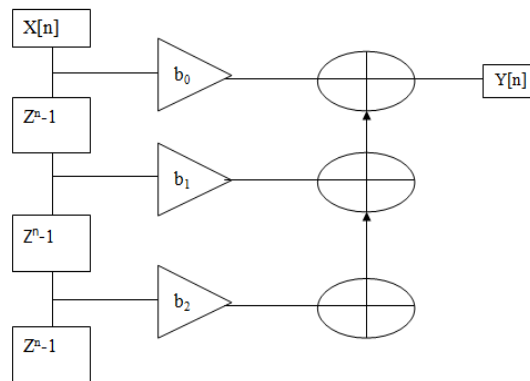

Fig.2.1 Structure of FIR filter

Application Specific Integrated Circuits (ASIC) and field programmable gate arrays (FPGA) stages. Systolic plans speak to an appealing engineering worldview for effective equipment usage of calculation serious DSP applications, being upheld by the elements like effortlessness, consistency, and seclusion of the structure. Furthermore, they likewise have critical potential to yield high-throughput rate by abusing abnormal state of simultaneousness utilizing pipelining or parallel handling or both. In any case, the multipliers in these structures require a substantial bit of the chip-territory and thusly uphold impediment on the greatest conceivable number of processing elements (PEs) that can be suited and the most elevated request of the filter that can be figured it out. Multiplier less distributed arithmetic (DA)- based system, has increased considerable fame, lately, for their high-throughput handling capacity, and expanded consistency which brings about financially savvy and territory time productive processing structures.

III. EXISTING SYSTEM

- In existing system, a novel RFIR filter design based on statistics centric reconfigurable (SCR) FIR filter architecture was designed.
- A novel Canonic Signed Digit (CSD) coefficient grouping method is proposed simply by identifying whether there is only one single "zero" bit between two "non-zero" bits. Through analyzing distributions of the selected CSs among a large quantity of CSD coefficients taken from a widely representative the FIR filter designs, some statistical characteristics are observed and exploited.
- A novel Processing Element (PE) structure for the medium-grain array architecture of reconfigurable FIR filters is proposed to achieve optimized utilization of logic resources for high performance.
- The PE can be easily cascaded on a modular basis and is readily adopted for FPGA or application specified integrated circuit (ASIC) implementations.
- They have used normal full adder, pipeline adder, and parallel adder etc. That adder based techniques occupied more area, more power, high critical path, and more hardware utilization in FPGA implementation.

International Journal of Innovative Research in Science, Engineering and Technology

(A High Impact Factor, Monthly, Peer Reviewed Journal)

Visit: www.ijirset.com

Vol. 8, Issue 4, April 2019

- The grouping flow for Canonic Signed Digit (CSD) coefficients is shown in the below figure 3.1.
- Figure 3.2, shows the architecture of a RFIR filter. The primary task of the pre-computer is to generate the partial products required by the coefficient multiplication. The partial products generated by the precomputer are then distributed to the cascaded array of Processing Element, and the coefficient multiplication is subsequently performed in the Processing Element, each performing shift and addition/subtraction operations.

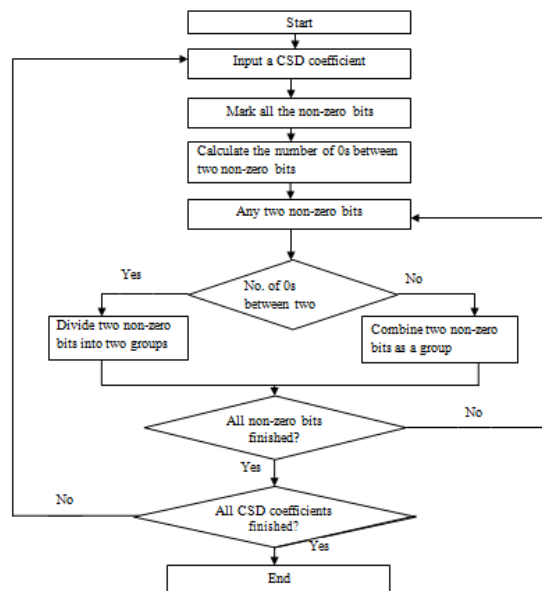

Fig.3.1 Grouping flow for Canonic Signed Digit (CSD) coefficients

- After selecting among the partial products generated from the pre-computer, a Processing Element accomplishes multiplication by performing required shifts and additions on those partial product.

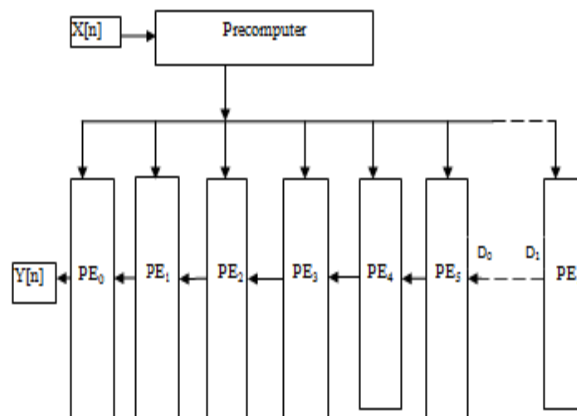

Fig.3.2 Architecture of a Reconfigurable FIR filter

International Journal of Innovative Research in Science, Engineering and Technology

(A High Impact Factor, Monthly, Peer Reviewed Journal)

Visit: www.ijirset.com

Vol. 8, Issue 4, April 2019

- But limitation of this method is that delay value is high because of decreased system speed and throughput. To overcome these problems, LC-CBA-RFIR method is introduced for evaluating ASIC implementation results and FPGA implementation results.
- Low Cost Carry Bypass adder Reconfigurable Finite Impulse Response (LC-CBA-RFIR) is designed to perform the RFIR filter operations. In the CBA, Ripple Carry Adder (RCA) is employed to add four-bits at a time and the carry generated will be propagated to next stage with the help of multiplexer utilizing selected input as Bypass logic.

IV. PROPOSED SYSTEM

- In the proposed system the multiplier is constructed by using adder cell. The CSA multiplier building block is containing half adder and full adder circuit. The proposed full adder circuit as shown in figure below combines the multiplexing operation for the sum operation and the carry operation. The sum and carry circuits are designed based on Standard full adder equations.
- Full adder equation for SUM is
 $SUM = C(A'B + AB) + C'(A'B + AB')$
- Another form in which SUM can be implemented as
 $SUM = C \text{ XOR } (A \text{ XOR } B)$
- Full adder equation for CARRY is
 $CARRY = AB + BC + AC$
- Another form in which CARRY can be implemented as
 $CARRY = AB + C(A \text{ EXOR } B)$
- An input C and its complement are used as the control signal of the sum circuit. The two-input X-OR gate is developed using the multiplexer method. The output node of the two input multiplexer circuit is the differential node
- According to standard full adder equation, the sum circuits need three inputs. In order to avoid increasing the number of transistors due to the addition of a third input, the following arrangement is made, the CPL(Complimentary Pass Transistor Logic) XOR gate multiplying with C's complement input and EX-NOR gate is multiplied with input C, and thereby reducing the number of transistors in the sum circuit.
- The truth table of full adder is given below

INPUTS			OUTPUTS	
A	B	C	SUM	CARRY
0	0	0	0	0
0	0	1	1	0
0	1	0	1	0
0	1	1	0	1
1	0	0	1	0
1	0	1	0	1
1	1	0	0	1
1	1	1	1	1

Table 4.1 Truth table of full adder

4.1.1 MULTIPLEXING LOGIC

The multiplexer switch one of several input to a single common output line. In multiplexer select lines determine which input is connected to output. The Carry save Array (CSA) multiplier is a linear array multiplier. As the

International Journal of Innovative Research in Science, Engineering and Technology

(A High Impact Factor, Monthly, Peer Reviewed Journal)

Visit: www.ijirset.com

Vol. 8, Issue 4, April 2019

operand size increases, linear arrays grow at a rate equal to the square of the operand size because the number of rows in the array is equal to the length of the multiplier, and the width of each row is equal to the width of multiplicand. The circuit diagram of the median filter using full adder cell is shown in the below figure 4.1.

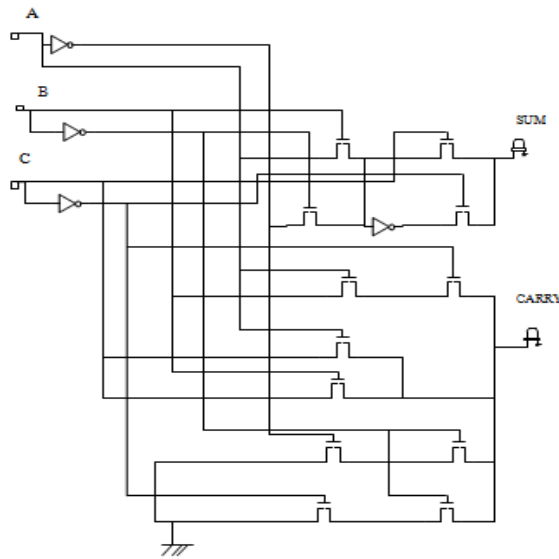

Fig.4.1. Proposed Full Adder

The block diagram of sorting to find the median value of pixel is shown in the below figure 4.2.

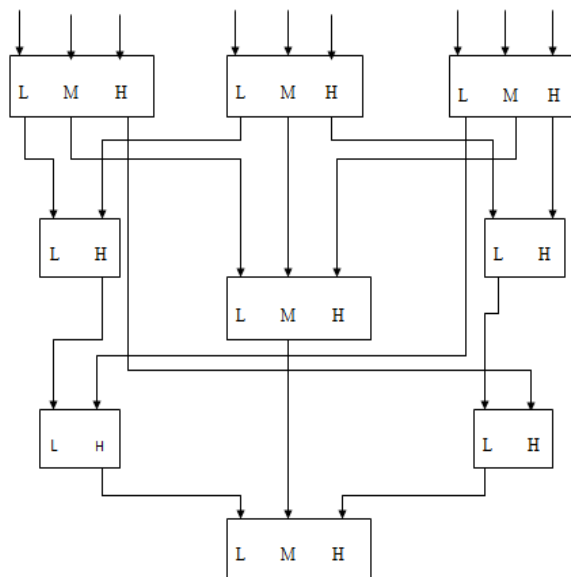

Fig.4.2 Block diagram of the sorter to find the median

International Journal of Innovative Research in Science, Engineering and Technology

(A High Impact Factor, Monthly, Peer Reviewed Journal)

Visit: www.ijirset.com

Vol. 8, Issue 4, April 2019

4.1.2 ADVANTAGES OF PROPOSED SYSTEM

- Low cost.
- Less Area.
- Low power and
- High speed operation.

V.RESULT AND DISCUSSION

The Median filter using full adder cell was designed and analysed. The circuit was simulated in microwind and their results were obtained. The comparison of area, power and delay for existing and proposed methods is presented in table 5.1.

Table 5.1 Performance Comparison of Existing and Proposed method

METHOD	TECHNOLOGY	AREA (µm)	POWER (µW)	DELAY (ps)
EXISTING METHOD	180nm	520.9798	8345.1315	280
MEDIAN FILTER USING FULL ADDER CELL	120nm	0.12	46.97	100

In the multiplier array, a full adder with balanced carry and sum delays is desirable because the sum and carry signals are in the critical path. The speed and power of the full adder are very important for large arrays. Our proposed 1-bit adder cell consumes less power, and less area than the various proposed 1-bit adder cells, due to regular arrangement of transistor tree structure, less critical path and multiplexing method of designs. The only drawback of our proposed adder cell is that it occupies larger area. From the simulated results it is clear that the multiplier circuits designed based on the proposed adder cell gives better performance in terms of power, area than the CP L-based adder cell..

A. SIMULATION RESULTS

The simulation results by means of Microwind and DSCH tool. The microwind program allows to propose and simulating an integrated circuit at physical description level. MICROWIND is really integrated EDA software encompassing IC designs from concept to completion, enabling chip designers to design beyond their mind. MICROWIND integrates traditionally separated front-end and back-end chip design into an integrated flow, accelerating the design cycle and reduced design complexities.

The DSCH program is a logic editor and simulator. DSCH is use to confirm the architecture of the logic circuit previous to the microelectronics design is happening. DSCH provides a user-friendly environment for hierarchical logic design, and fast simulation with delay analysis, which allows the design and validation of complex logic structures. Fig.5.1, shows the schematic design of proposed full adder.

International Journal of Innovative Research in Science, Engineering and Technology

(A High Impact Factor, Monthly, Peer Reviewed Journal)

Visit: www.ijirset.com

Vol. 8, Issue 4, April 2019

The microwind MOS layout is shown in the below figure 5.2. The simulation results are shown in below figures 5.3(Voltage vs Time),5.4 (Voltage vs Current) 5.5 (Voltage vs Voltage), 5.6 (Frequency vs Time), 5.7(Eye diagram) respectively.

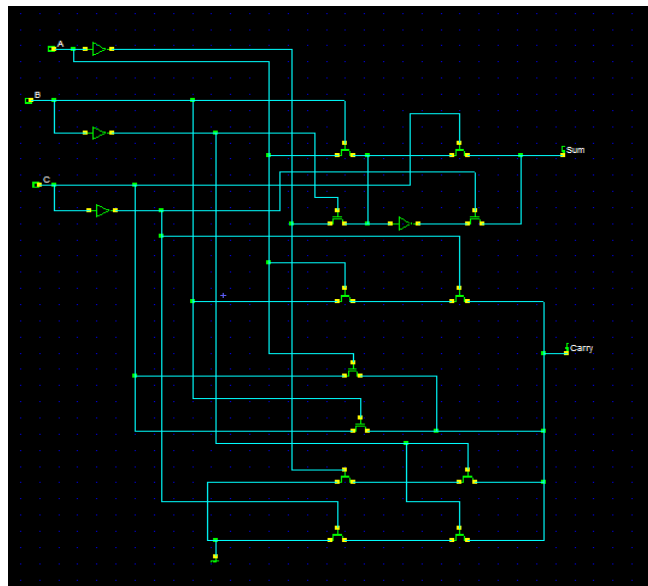

Fig.5.1 Schematic Design of proposed full adder

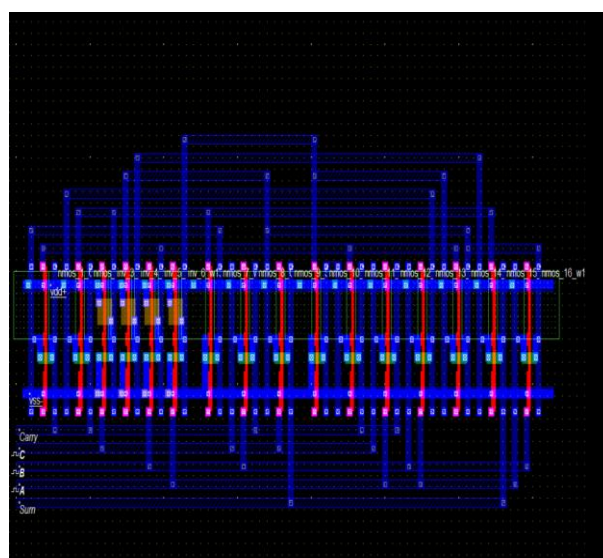

Fig.5.2 Microwind MOS layout

International Journal of Innovative Research in Science, Engineering and Technology

(A High Impact Factor, Monthly, Peer Reviewed Journal)

Visit: www.ijirset.com

Vol. 8, Issue 4, April 2019

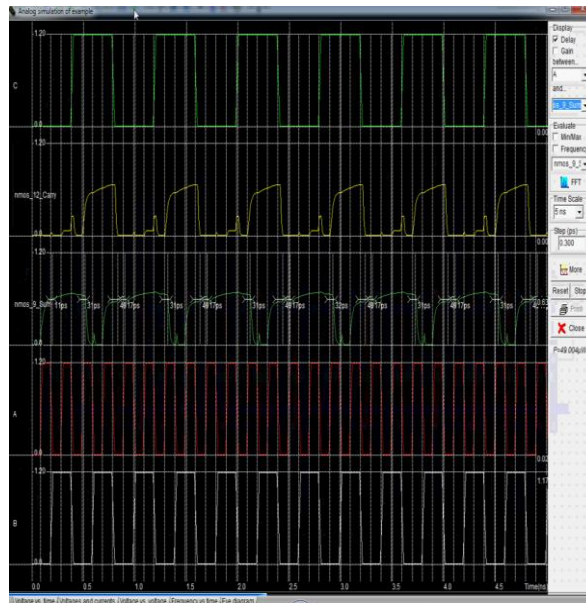

Fig.5.3 Simulation Waveform for Voltage Vs Time

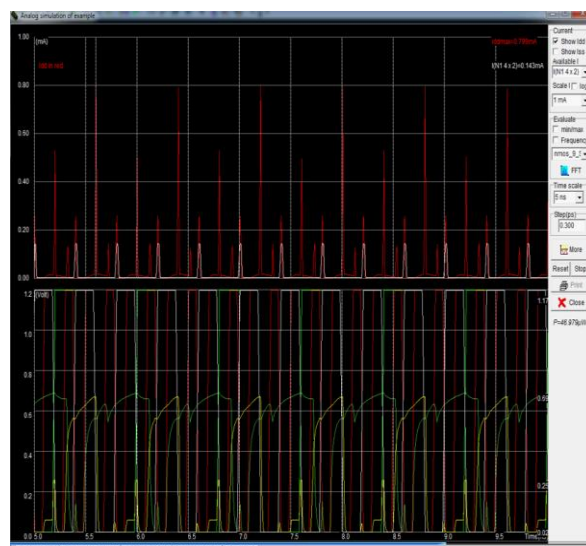

Fig.5.4 Simulation Waveform for Voltage Vs Current

International Journal of Innovative Research in Science, Engineering and Technology

(A High Impact Factor, Monthly, Peer Reviewed Journal)

Visit: www.ijirset.com

Vol. 8, Issue 4, April 2019

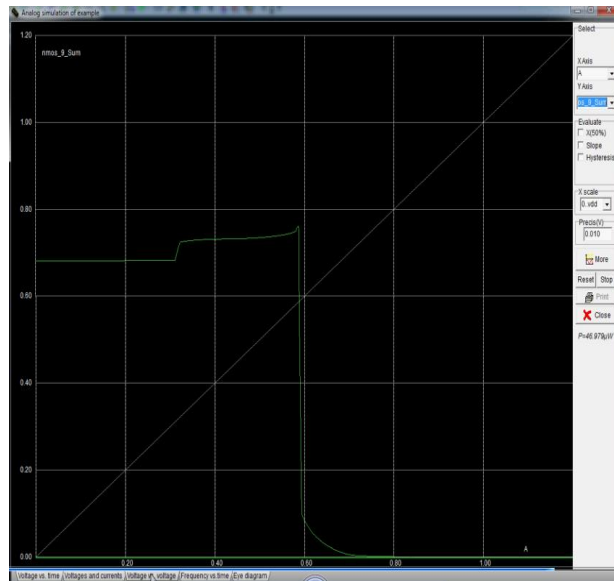

Fig.5.5 Simulation Waveform for Voltage Vs Voltage

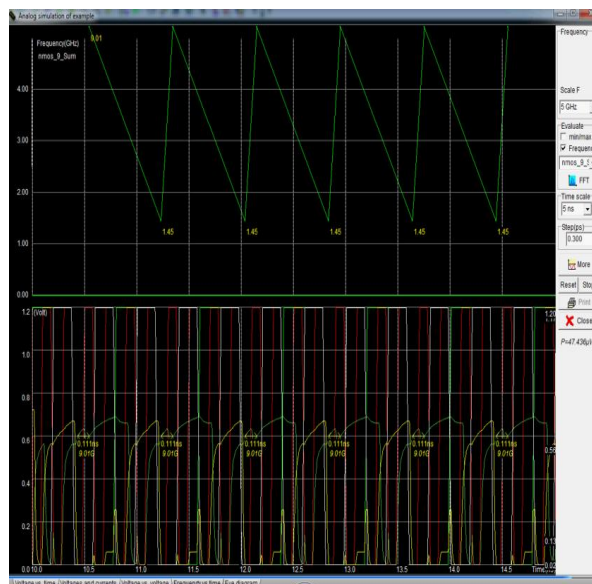

Fig 5.6 Simulation Waveform for Frequency Vs Time

International Journal of Innovative Research in Science, Engineering and Technology

(A High Impact Factor, Monthly, Peer Reviewed Journal)

Visit: www.ijirset.com

Vol. 8, Issue 4, April 2019

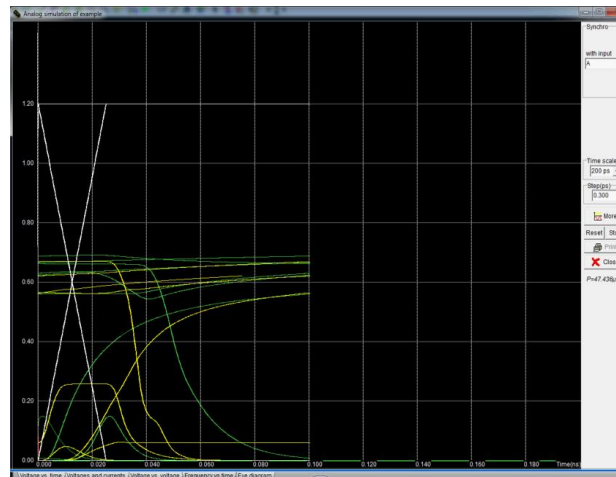

Fig 5.7 Eye Diagram

VI.CONCLUSION

The full adder based CSA(Carry Save Array) multipliers circuits are simulated by using Microwind software. The circuits were compared with existing circuits. The results were compared with existing results. The power and area were reduced more than 50% than existing circuits and propagation delay also reduced. Thus Full adder based multiplier gives better performance than existing circuits in terms of power dissipation and area. The proposed multiplier circuits can be used in the low power application of VLSI circuits.

REFERENCES

- [1] A. Bonetti, A. Teman, P. Flatresse, and A. Burg, "Multipliers-Driven Perturbation of Coefficients for Low-Power Operation in Reconfigurable FIR Filters", IEEE Transactions on Circuits and Systems I: Regular Papers, Vol.64, No.9, pp. 2388 – 2400, 2017.
- [2] J. Chen, J. Tan, C.H. Chang, and F. Feng, "A new cost-aware sensitivity-driven algorithm for the design of FIR filters", IEEE Transactions on Circuits and Systems I: Regular Papers, Vol.64, No.6, pp.1588-1598, 2017.
- [3] C.Y. Yao, W.C. Hsia, and Y.H. Ho, "Designing hardware-efficient fixed-point FIR filters in an expanding subexpression space", IEEE Transactions on Circuits and Systems I: Regular Papers, Vol.61, No.1, pp.202-212, 2014.
- [4] N. Bhagyalakshmi, K.R. Rekha, and K.R. Nataraj, "Design and implementation of DA-based reconfigurable FIR digital filter on FPGA", In: Proc. of International Conf. on Emerging Research in Electronics, Computer Science and Technology (ICERECT), pp.214-217, 2015.
- [5] A. Liacha, A.K. Oudjida, F. Ferguene, M. Bakiri, and M.L. Berrandjia, "Design of high-speed, low-power, and area-efficient FIR filters", IET Circuits, Devices & Systems, Vol.12, No.1, pp.1-11, 2017.
- [6] M. Alawad and M. Lin, "FIR filter based on stochastic computing with reconfigurable digital fabric", In: Proc. of the International Conf. on Field-Programmable Custom Computing Machines (FCCM), pp.92-95, 2015.
- [7] A. Rasekh and M.S. Bakhtiar, "Design of Low-Power Low-Area Tunable Active RC Filters", IEEE Transactions on Circuits and Systems II: Express Briefs, Vol.65, No.1, pp.6-10, 2018.
- [8] P.K. Meher and S.Y. Park, "High-throughput pipelined realization of adaptive FIR filter based on distributed arithmetic", In: Proc. of the 19th International Conf. on VLSI and System-on-Chip (VLSI-SoC), pp.428-433, 2011.
- [9] C.S.V. Patnam and E. Chitra, "Efficient FPGA Realization of DA-Based Reconfigurable FIR Digital Filter", IJRECE, Vol.3, No.2, pp.24-28, 2015.
- [10] S. Bhattacharjee, S. Sil, and A. Chakrabarti, "Evaluation of Power Efficient FIR Filter for FPGA based DSP Applications", Procedia Technology, Vol.10, pp.856-865, 2013.
- [11] J.L.M. Iqbal and S. Varadarajan, "High Performance Reconfigurable FIR Filter Architecture Using Optimized Multiplier", Circuits, Systems, and Signal Processing, Vol.32, No.2, pp.663-682, 2013.
- [12] R. Thakur and K. Khare, "High Speed FPGA Implementation of FIR Filter for DSP Applications", International Journal of Modeling and Optimization, Vol.3, No.1, pp.92, 2013.
- [13] S.J. Lee, J.W. Choi, S.W. Kim, and J. Park, "A reconfigurable FIR filter architecture to trade off filter performance for dynamic power consumption", IEEE transactions on very large scale integration (VLSI) systems, Vol.19, No.12, pp.2221-2228, 2011.
- [14] P. Stalin and C. Arun, "A Study on Low Power Reconfigurable FIR Filters with Dynamic Change in Filter Order", Journal of Theoretical & Applied Information Technology, Vol.54, No.2, pp.230-237, 2013.