

# Performance and Analysis of PAPR Reduction for Wireless Communication Using ZCT

Kavita Jat, Aabhas Mathur, Dr. Hemant Dhabai

Research Scholar, M.Tech. (D.C), Arawali Institute of Technical Studies, Udaipur, Rajasthan, India

Associate Professor & Head, Arawali Institute of Technical Studies, Udaipur, Rajasthan, India

Professor, Arawali Institute of Technical Studies, Udaipur, Rajasthan, India

**ABSTRACT:** in this paper proposed a combine technique of precoding and PTS to reduce the PAPR. This hybrid combined technique reduces PAPR effectively and also minimizes the complexity of PTS technique which arises due to number of sub blocks. In PTS scheme, as the number of sub blocks increases, the IFFT operation to be performed for sub blocks also increases. Simulation results have shown that the decrement of PAPR of proposed scheme is more than PTS and precoding methods as well as the complexity reduced significantly. The out of band radiation of proposed scheme is less than original OFDM as shown in power spectral density (PSD) simulation result.

**KEYWORDS:** OFDM,UF-OFDM,F OFDM,ZCT,QAM

## I. INTRODUCTION

The necessity of high data rate draws the great attention in multi-carrier system. It should be capable to operate smoothly in environment of high carrier frequency, high data transmission rate and mobility. The studied has shown that OFDM fulfil the multi-carrier system necessities. OFDM is a multi-carrier modulation (MCM) technique in which complex data symbols (i.e, BPSK, QPSK, QAM, MPSK etc.) are transmitted in parallel after modulating them over orthogonal sub-carrier. In single carrier (SC) system, one complex data is transmitted using one carrier and in this parallel transmission, complex data is transmitted over sub-carrier. Here the effective data rate of the system is same as of SC system. The parallel transmission increases the time period of symbol and the comparative amount of separation in time caused by multipath delay decreases. In OFDM system, the orthogonality among sub-carriers is maintained by using inverse Fast Fourier Transform (IFFT) as shown in figure (2.1). A guard band is inserted between successive OFDM symbols. Insertion of guard band in OFDM symbols can be done by three methods- cyclic prefix, cyclic suffix and zero padding. By adding guard band in OFDM symbols, OFDM convert wideband frequency selective channel into collection of parallel narrowband flat fading channel, one channel across each subcarrier. Thus it removes Inter-Symbol Interference (ISI). Due to features like high immune to multipath fading, high data transmission rate and requirement of less complex equalizer, OFDM has been exploited by many high data rate broadband wireless communication systems of present generation [1], [2]. The demand for higher data rate communication always provides the impetus for doing research in the OFDM field. One of the challenging issue of OFDM system is high peak to average power ratio (PAPR). High PAPR force the high power amplifier (HPA) to operate in non-linear Region. This operation in non-linear region degrade the power efficiency of the amplifier simultaneously requires large back-off power, introduce ISI in OFDM system and hence, degrade the bit error rate (BER) performance. Numerous techniques have been proposed during the period of 10 years for reducing the PAPR. The main problems regarding these techniques are computational complexity, HPA efficiency and BER performance. The main purpose of this thesis is to study and analyse the PAPR reduction techniques of the OFDM system and then to propose new scheme with low computational complexity as well as less influence on HPA efficiency and BER performance.

## International Journal of Innovative Research in Science, Engineering and Technology

(A High Impact Factor, Monthly, Peer Reviewed Journal)

Visit: [www.ijirset.com](http://www.ijirset.com)

Vol. 8, Issue 8, August 2019

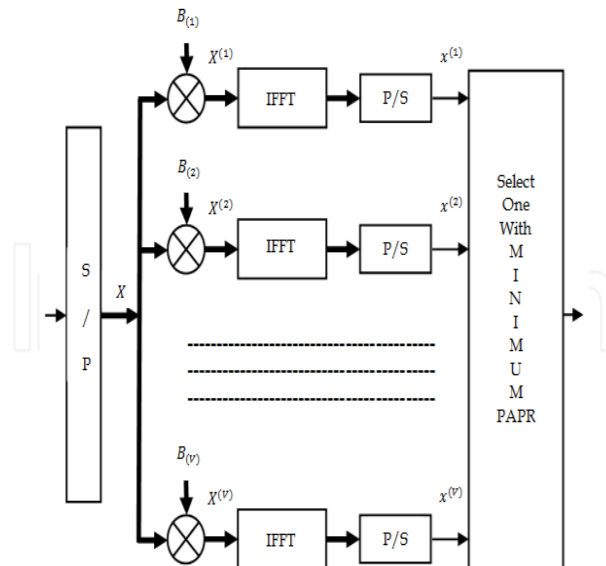

Fig1 Block diagram of OFDM system

The discrete time baseband OFDM system with subcarriers is shown in figure 2.1. It consists of transmitter, channel and receiver blocks. In this model, a block of input bits (symbols) are modulated by M-ary data modulators and then, such symbols are transferred by the serial to parallel converter. Different types of data modulator can be used depending upon system requirement (e.g. M-PSK, M-QAM etc.). The complex parallel data symbols ( ) obtained by using modulation techniques are given to point IFFT block as shown in figure 2.1. The complex envelope of the baseband transmitted OFDM signal can be The mobile Worldwide Interoperability for Microwave Access (Mobile WiMAX) air interface adopts orthogonal frequency division multiple access (OFDMA) as multiple access technique for its uplink (UL) and downlink (DL) to improve the multipath performance. All OFDMA based networks including mobile WiMAX experience the problem of high peak-to-average power ratio (PAPR). The literature is replete with a large number of PAPR reduction techniques. Among them, schemes like constellation shaping, phase optimization, nonlinear companding transforms, tone reservation (TR) and tone injection (TI), clipping and filtering, partial transmit sequence (PTS), precoding based techniques, selective mapping (SLM), precoding based selective mapping (PSLM) and phase modulation transform are popular. The precoding based techniques, however, show great promise as they are simple linear techniques to implement without the need of any complex optimizations. This chapter reviews these PAPR reduction techniques and presents a Zadoff-Chu matrix transform (ZCMT) based precoding technique for PAPR reduction in mobile WiMAX systems. The mobile WiMAX systems employing random-interleaved OFDMA uplink system has been used for determining the improvement in PAPR performance of the technique. It has been further used in selective mapping (SLM) based ZCT precoded random-interleaved OFDMA uplink system. PAPR of these systems are analyzed with the root-raised-cosine (RRC) pulse shaping to keep out-of-band radiation low and to meet the transmission spectrum mask requirement. Simulation results show that the proposed systems have low PAPR than the Walsh-Hadamard transform (WHT) precoded random-interleaved OFDMA uplink systems and the conventional random-interleaved OFDMA uplink systems. The symbol-error-rate (SER) performance of these uplink systems is also better than the conventional random-interleaved OFDMA uplink systems and at par with WHT based random-interleaved OFDMA uplink systems. The good improvement in PAPR offered by the presented systems significantly reduces the cost and the complexity of the transmitter

## International Journal of Innovative Research in Science, Engineering and Technology

(A High Impact Factor, Monthly, Peer Reviewed Journal)

Visit: [www.ijirset.com](http://www.ijirset.com)

Vol. 8, Issue 8, August 2019

### II. PROPOSED METHOD

In this proposed system a precoding-based PAPR reduction technique is done by using the Zadoff-Chu transform precoding method for both the UF-OFDM and the F-OFDM systems. The principle of this method is to transform the UF-OFDM signal to a lower order summation of single carrier signals and the F-OFDM signal to single carrier signal. The performance of the

proposed PAPR reduction technique is evaluated by the simulation results obtained. The proposed simulation results which shows that the proposed system which out performs that the existing precoding technique. The performance results which shows the better simulations.

- Computational complexity is low as compared to the existing system.
- The precoding technique which shows the better results.
- Precoding reduces the PAPR without increase the complexity of the system.
- The system also produces the better results for the IAPR and the normalized (PSD) results.
- ZCT precoding is distortion less.

$$a_n = \begin{cases} e^{j2\pi \left( \frac{k^2}{2} + qk \right)}, & \text{for } N \text{ even} \\ e^{j2\pi \left( \frac{k(k+1)}{2} + qk \right)}, & \text{for } N \text{ odd} \end{cases}$$

ZCT does not require any optimization algorithm

### III. ZCT PRECODING MODEL

Zadoff-Chu codes are the special case of the generalized Chip-Like polyphase sequences having optimum correlation properties. Zadoff-Chu sequences have an ideal periodic condition. In the ZCT precoded OFDM systems, the baseband modulated data is passed through S/P converter which generates a complex vector of size L that can be written as  $X = [X_0, X_1, X_2, \dots, X_{L-1}]$ . Then ZCT precoding is applied to this complex vector which transforms this complex vector into new vector of same length. The frequency domain PAPR reduction technique is better than time domain because of its ability to reduce the PAPR without distorting the transmitted signals and thus not producing any in band distortion and out of band radiation. Among many available techniques of frequency domain, PTS and precoding are the best frequency domain methods to reduce PAPR as compare to others. PTS method is distortion less method because it divides frequency vector into some sub-blocks before applying the phase transformation. The main issue of this scheme is increment in complexity due to increased number of subblocks, number of selection of phase factors and amount of side information to be sent for recovery of original signal. Precoding technique reduces the PAPR with less complexity but the number of subcarriers increases with increase in roll off factor. Here, we proposed the combine technique of precoding and PTS to reduce the PAPR of OFDM system. This method is mainly focused to reduce PAPR and to minimize the complexity which arises due to number of subblocks. The complexity associated with PTS regarding the increased number of subblocks is the requirement of more IFFT operation to be performed for subblocks. So, this proposed method obtain the considerable reduction in PAPR using few number of subblocks as comparison to the PAPR obtained by using large number of subblocks in PTS scheme.

### IV. PAPR REDUCTION

PAPR reduction methods can be mainly divided into two domain methods: frequency domain method and time domain method [30]. The basic notion of frequency domain method is to increase the cross correlation of the input signal before IDFT and decrease the output of the IDFT peak value or average value. Selective Mapping (SLM), Partial Transmit Sequence (PTS), Precoding etc. schemes are example of frequency domain method. However, in time domain method

# International Journal of Innovative Research in Science, Engineering and Technology

(A High Impact Factor, Monthly, Peer Reviewed Journal)

Visit: [www.ijirset.com](http://www.ijirset.com)

Vol. 8, Issue 8, August 2019

PAPR is reduced by distorting the signal before amplification and added of extra signals which increase the average power. Clipping and filtering, Peak widening etc. are examples of time domain method. It is very simple method because it requires very less computational time but introduces the distortion, increases out of band radiation and also degrades BER performance. On comparing between these two domain methods, frequency domain PAPR reduction technique is the most efficient one because of its ability to compress the PAPR without distorting the transmitted signal, no production of in band distortion and out of band radiation in OFDM signals. Broadly PAPR reduction techniques are classified into four sections [31].

## MODULES

- OFDM Symbol Generation Model
- Modulation and filtering Model
- ZCT Precoding Model
- Performance Analysis

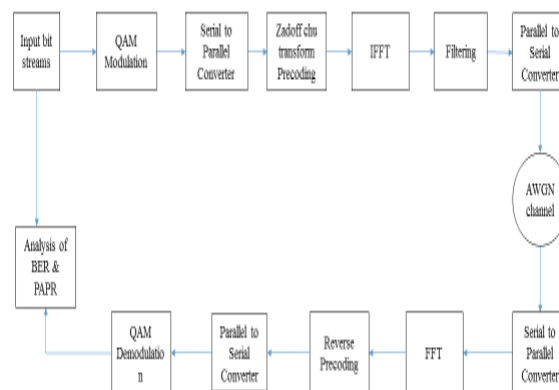

Fig.2 proposed Block diagram of OFDM system

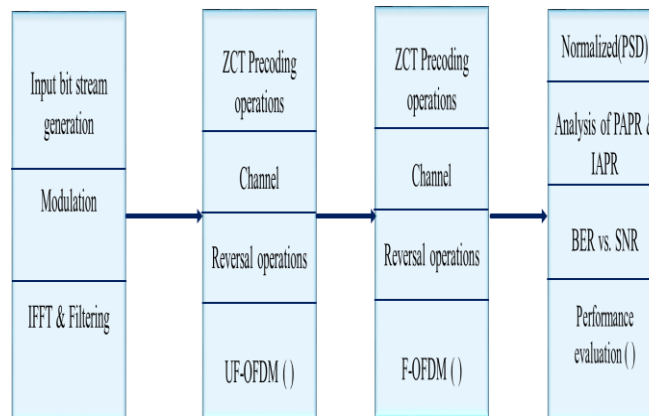

Fig.3 sequence diagram of OFDM system

**A-OFDM SYMBOL GENERATION:** Using a large number of parallel narrow-band subcarriers instead of a single wide-band carrier to transport information. OFDM is a frequency-division multiplexing (FDM) scheme used as a digital multi-carrier modulation method and is essentially identical to coded OFDM (COFDM) and discrete multi-tone modulation (DMT). It is used in such diverse applications as digital television and audio broadcasting, wireless

## International Journal of Innovative Research in Science, Engineering and Technology

(A High Impact Factor, Monthly, Peer Reviewed Journal)

Visit: [www.ijirset.com](http://www.ijirset.com)

Vol. 8, Issue 8, August 2019

networking and broadband internet access. OFDM has also been adopted in some military communication systems. In an OFDM scheme, a large number of orthogonal, overlapping, narrow band sub-channels or subcarriers, transmitted in parallel, divide the available transmission bandwidth. The separation of the subcarriers is theoretically minimal such that there is a very compact spectral utilization. The attraction of OFDM is mainly due to how the system handles the multipath interference at the receiver. Multipath generates two effects: frequency selective fading and intersymbol interference (ISI). The "flatness" perceived by a narrow-band channel overcomes the former, and modulating at a very low symbol rate, which makes the symbols much longer than the channel impulse response, diminishes the latter. Using powerful error correcting codes together with time and frequency interleaving yields even more robustness against frequency selective fading and the insertion of an extra guard interval between consecutive OFDM symbols can reduce the effects of ISI even more. Thus, an equalizer in the receiver is not necessary.

**B-PRECODING METHOD:** In precoding method, modulated data is multiplied with shaping matrix before the formation of OFDM symbol (before IFFT) as shown in figure (3.7). This type of technique utilizes the positive feature of the frequency selective multipath channel of OFDM system [35], [36]. In figure (3.7), first the input data is modulated in baseband using modulation scheme like M-PSK, M-QAM etc. The baseband-modulated data stream is transformed by precoding matrix. Different methods like pulse shaping function, discrete cosine transformation (DCT) matrix, Hadamard matrix, Zadoff-chu sequence, generalized chirp-like (GCL) sequence etc. are used to generate precoding matrix. After that these precoded data are transmitted through IFFT and generate OFDM symbols. Each element of precoding matrix should be carefully designed, so that it can reduce the PAPR. Since, we are multiplying modulated data with predefined precoding matrix; there is no need of handshake between transmitter and receiver.

**C-ZCT PRECODING MODEL:** Zadoff-Chu codes are the special case of the generalized Chip-Like polyphase sequences having optimum correlation properties. Zadoff-Chu sequences have ideal periodic conditions.

In the ZCT precoded OFDM systems, the baseband modulated data is passed through S/P converter which generates a complex vector of size L that can be written as  $X = [X_0, X_1, X_2 \dots X_{L-1}]$ . Then ZCT precoding is applied to this complex vector which transforms this complex vector into new vector of same length

**D-PERFORMANCE ANALYSIS:** The peak-to-average power ratio (PAPR) is the peak amplitude squared (giving the peak power) divided by the RMS value squared (giving the average power). It is the square of the crest factor:

$$PAPR = \frac{|x|_{\text{peak}}^2}{x_{\text{rms}}^2} = C^2.$$

$$PAPR_{dB} = 10 \log_{10} \frac{|x|_{\text{peak}}^2}{x_{\text{rms}}^2} = C_{dB}^2.$$

When expressed in decibels, crest factor and PAPR are equivalent, due to the way decibels are calculated for power ratios vs amplitude ratios. The bit error rate (BER) is the number of bit errors per unit time. The bit error ratio (also BER) is the number of bit errors divided by the total number of transferred bits during a studied time interval. BER is a unit less performance measure, often expressed as a percentage.

The bit error probability is the expectation value of the bit error ratio. The bit error ratio can be considered as an approximate estimate of the bit error probability. This estimate is accurate for a long time interval and a high number of bit errors. In the case of QPSK modulation and AWGN channel, the BER as function of the  $E_b/N_0$  is given by:

$$BER = \frac{1}{2} \text{erfc}(\sqrt{E_b/N_0})$$

# International Journal of Innovative Research in Science, Engineering and Technology

(A High Impact Factor, Monthly, Peer Reviewed Journal)

Visit: [www.ijirset.com](http://www.ijirset.com)

Vol. 8, Issue 8, August 2019

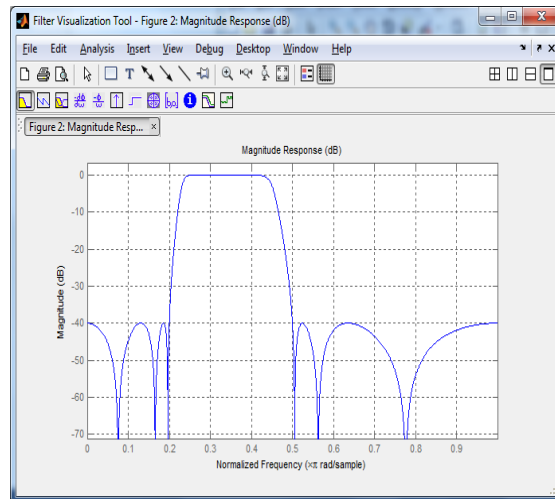

Figure-3 Power spectral density (PSD) of proposed method.

$$a_n = \begin{cases} e^{\frac{j2\pi}{N} \left( \frac{k^2}{2} + qk \right)}, & \text{for } N \text{ even} \\ e^{\frac{j2\pi}{N} \left( \frac{k(k+1)}{2} + qk \right)}, & \text{for } N \text{ odd} \end{cases}$$

Figure 4.5 show that the proposed method has low PSD as compared to the original OFDM. roll of factor, four sub blocks as well as oversampling factor four is used for this method. Power spectral density for proposed method is approximately -50dB/MHz and about -40dB/MHz for original OFDM. PSD has constant transmit spectrum within the range of 0.2 to 0.5MHz. From -2MHz to 0MHz and 0MHz to 2MHz show side lobes of transmit spectrum. The PSD strength within the range of -0.5 to 0.5MHz.

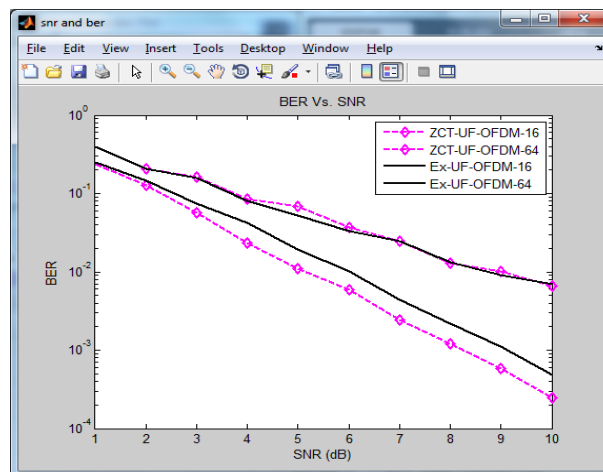

Figure-4. BER comparison between, the EX- UF-OFDM, the ZCT-UF-OFDM and for the 16-QAM and the 64-QAM constellations

## International Journal of Innovative Research in Science, Engineering and Technology

(A High Impact Factor, Monthly, Peer Reviewed Journal)

Visit: [www.ijirset.com](http://www.ijirset.com)

Vol. 8, Issue 8, August 2019

The BER performance of the EX--UFOFDM and the ZCT-UF-OFDM are compared to the ZCT- UF-OFDM for the 16-QAM and the 64-QAM constellations. As it is shown in this figure, the precoding has no effect on the BE performance in a AWGN channel. Hence, adding a precoding block to the modulation scheme improves the PAPR

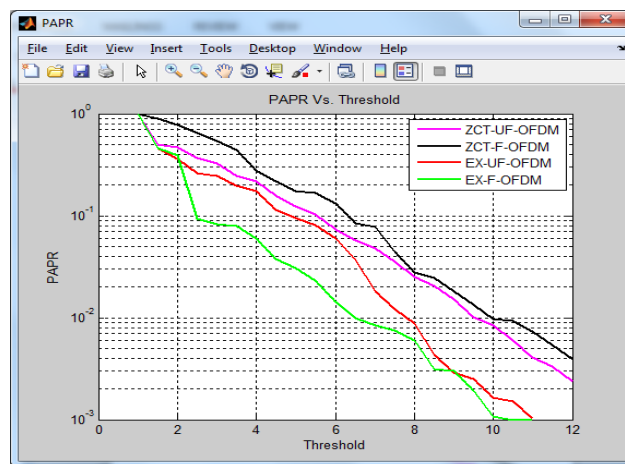

Figure-5 PAPR Vs threshold

This graph illustrates that at lower number of subblocks least PAPR is achieved. So, the complexity issue on ZCT UF-OFDM, due to number of sub blocks is addressed by achieving minimum PAPR at minimum sub blocks. Not only that, proposed method have PAPR of 5.5dB which is minimum in comparison to EX-technique at same roll-off factor with 5.8dB peak value as well as PTS technique with sub blocks 16 UF OFDM,EX-F OFDM,

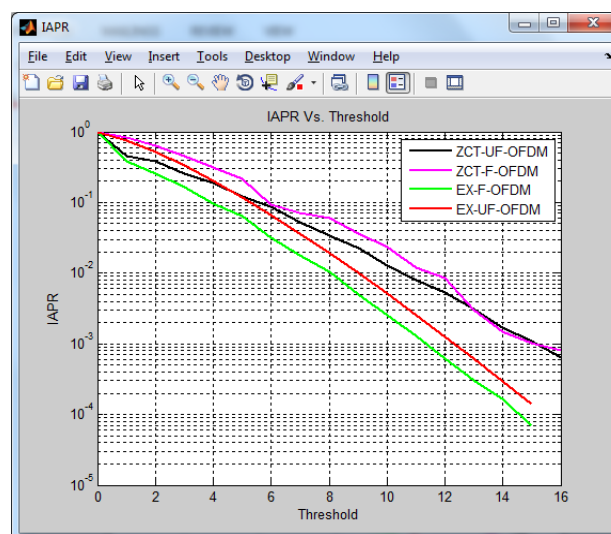

Figure-6 IPAPR Vs threshold

The main concept of the proposed method is to multiply encoded data with predefined ZCT-precoding matrix and applying these precoded data to ZCT-UF-OFDM,ZCT,F-OFDM,method where precoded data are partitioned into subblocks and

## International Journal of Innovative Research in Science, Engineering and Technology

(A High Impact Factor, Monthly, Peer Reviewed Journal)

Visit: [www.ijirset.com](http://www.ijirset.com)

Vol. 8, Issue 8, August 2019

choosing the optimized phase factor, the lowest IPAPR is obtained. From the result of the simulations, the proposed technique has low PAPR as compare to EX-F-OFDM,EX-UF-OFDM,. Using a few number of subblocks, a remarkable reduction in IPAPR is achieved. Therefore, complexity of more IFFT operations for Precoding method has been omitted because the proposed scheme achieves low PAPR by using few numbers of subblocks.

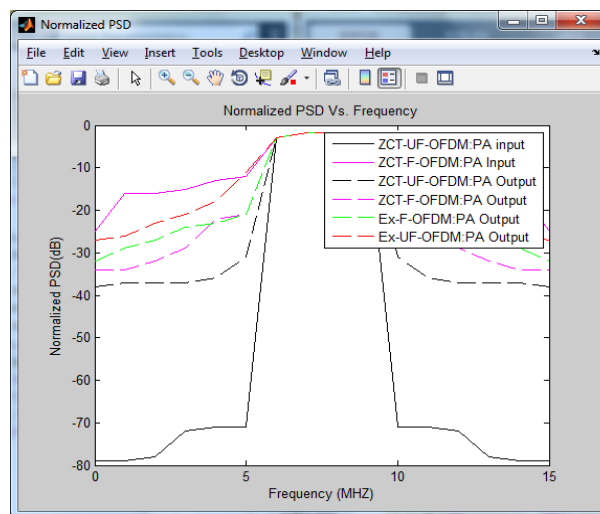

Figure-7 Power spectral density (PSD)

### V. CONCLUSION

We present a brief overview of the mobile WiMAX and typical PAPR reduction techniques available in the literature. We also introduce two precoding based systems: ZCMT precoded random-interleaved OFDMA uplink system and SLM based ZCMT precoded random-interleaved OFDMA uplink system, for PAPR reduction in mobile WiMAX systems. Computer simulation shows that the PAPR of the both proposed systems have less PAPR than the WHT precoded random-interleaved OFDMA uplink systems and conventional random-interleaved OFDMA uplink systems. These systems are efficient, signal independent, distortion less and do not require any complex optimizations. Additionally, these systems also take the advantage of the frequency variations of the communication channel and can also offer substantial performance gain in fading multipath channels. Thus, it is concluded that the both proposed uplink systems are more favourable than the WHT precoded random-interleaved OFDMA uplink systems and conventional random-interleaved OFDMA uplink systems for the mobile WiMAX systems.

### REFERENCES

1. A new ZCT precoded OFDM system with pulse shaping: PAPR analysis Imran Baig Varun Jeoti 2010 IEEE Asia Pacific Conference on Circuits and Systems Year: 2010
2. A PAPR Reduction Scheme based on Improved PTS with ABC Algorithm for OFDM Signal Tanairat Mata ; Pisit Boonsrimuang ; Pitchaya Boontra 2018 15th International Conference on Electrical Engineering/Electronics, Computer, Telecommunications and Information Technology (ECTI-CON) Year: 2018
3. A Novel Parallel Artificial Bee Colony Algorithm and Its PAPR Reduction Performance Using SLM Scheme in OFDM and MIMO-OFDM Systems Necmi Taşpınar ; Mahmut Yıldırım IEEE Communications Letters Year: 2015 Volume: 19, Issue: 10 |
4. Reduction of PAPR Using Block Coding Method and APSK Modulation Techniques for F-OFDM in 5G System Azlina Idris ; Nur Lisa Mohd Sapari ; Mohd Syarhan Idris ; Suzie Seroja Sarmin ; Wan Norsyafizan Wan Mohamad ; Nani Fadzlina Naim TENCON 2018 - 2018
5. Artificial signals addition for reducing PAPR of OFDM systems Desire Guel ; Jacques Palicot 2008 IEEE International Symposium on Signal Processing and Information Technology Year: 2008
6. PAPR Analysis of Class-III SLM Scheme Based on Variance of Correlation of Alternative OFDM Signal Sequences Jun-Young Woo ; Hyun Seung Joo ; Kee-Hoon Kim ; Jong-Seon No ; Dong-Joon Shin IEEE Communications Letters Year: 2015 | Volume: 19, Issue: 6



## International Journal of Innovative Research in Science, Engineering and Technology

(A High Impact Factor, Monthly, Peer Reviewed Journal)

Visit: [www.ijirset.com](http://www.ijirset.com)

Vol. 8, Issue 8, August 2019

7. A Modified SLM Scheme With Low Complexity for PAPR Reduction of OFDM Systems Seok-Joong Heo ; Hyung-Suk Noh ; Jong-Seon No ; Dong-Joon Shin IEEE Transactions on Broadcasting Year: 2007 | Volume: 53, Issue: 4
8. Precoding PTS scheme for PAPR reduction in OFDM Thota Sravanti ; N Vasantha 2017 International Conference on Innovations in Electrical, Electronics, Instrumentation and Media Technology (ICEEIMT) Year: 2017
9. S.B. Weinstein and P.M. Ebert, "Data Transmission by Frequency-Division Multiplexing Using the Discrete Fourier Transform," IEEE Transactions on Communication. Tech., vol. 19, pp. 628-634 October 1971.
10. L. j. Cimini jr "Analysis and simulation of a digital mobile channel using orthogonal frequency division multiplexing," IEEE Transactions communication, vol. 33, pp. 665-675, July 1985.
11. P. S. Chow, J. C. Tu and J. M. Cioffi, "Performance evaluation of a multichannel System for ADSL and VHDSL services," IEEE Selected Area, vol., SAC-9, no. 6, pp.909-91, August 1991.
12. T. Jiang, W. Xiang, H. H. Chen and Q. Ni, "Multicast broadcasting services support in OFDMA-based WiMAX systems," IEEE Communications Magazine, vol. 45, no. 8, pp. 78-86, Aug. 2007.
13. H. Sari, G. Karma and I. Jeaneclaude, "Transmission techniques for digital terrestrial TV broadcasting," *IEEE Communication Magazine*, vol. 33, pp. 100-109, February 1995.
14. H. Schulze and C. Luders, "Theory and Applications of OFDM and CDMA," 1<sup>st</sup> Edition, John Wiley & Sons, England, 2005.
15. Slimane Ben Slimane, "Peak to Average Power ratio reduction of OFDM signals using Pulse Shaping," IEEE, pp. 1412-1416, 2000.
16. H.D. Joshi and R. Saxena, "OFDM and its Major Concerns: A Study with Way Out," IETE Journal of Education, vol. 54, Issued. 1, pp. 1-49, Jan-Jun. 2013.