

# Analysis of PAPR Reduction in OFDM Using ZCT Precoding

Kavita Jat, Aabhas Mathur, Dr. Hemant Dhabai

Research scholar M.Tech. (D.C), Arawali Institute of Technical Studies, Udaipur, Rajasthan, India

Associate Professor & Head, Arawali Institute of Technical Studies, Udaipur, Rajasthan, India

Professor, Arawali Institute of Technical Studies, Udaipur, Rajasthan, India

**ABSTRACT** :High Peak to Average Power Ratio is one of the major drawbacks in Orthogonal Frequency Division Multiplexing (OFDM) OFDM suffers from high peak-to-average power ratio (PAPR) problem, which reduces the power amplifier (PA) efficiency or worse it degrades bit error rate (BER) performance and increases out-of-band radiation. In order to preserve the linearity without reducing PA efficiency, many PAPR reduction techniques are used in the literature.1 PAPR reduction techniques may be classified according to strategy into a three categories: adding signal techniques, multiple signal representation (MSR) techniques, and finally coding and precoding techniques We proposed a combine technique of precoding and PTS to reduce the PAPR. This hybrid combined technique reduces as the number of sub blocks increases the IFFT operation to be performed for sub blocks also increases. Simulation results have shown that the decrement of PAPR of proposed scheme is more than PTS and precoding methods as well as the complexity reduced significantly. The out of band radiation of proposed scheme is less than original OFDM as shown in power spectral density (PSD) simulation result

**KEYWORDS**:-OFDM,PAPR,IAPR,BER,PSD

## I. INRODUCTION

There are two different approaches to do subcarrier mapping in OFDMA systems, localized subcarrier mapping and distributed subcarrier mapping. The distributed subcarrier mapping can be further divided in to two modes, interleaved mode and random interleaved mode. Fig.1 shows the subcarrier mapping in interleaved mode, where the subcarriers are mapped equidistant to each other's. Fig.2 explains the subcarrier mapping in random-interleaved mode, where the subcarriers are mapped randomly based on some permutation algorithm to each other's. Further explains the concept of localized subcarrier mapping, where the subcarrier mapping is done in adjacent. The demand for higher data rate communication always provides the impetus for doing research in the OFDM field. One of the challenging issue of OFDM system is high peak to average power ratio (PAPR). High PAPR force the high power amplifier (HPA) to operate in non-Linear region. This operation in non-linear region degrade the power efficiency of the amplifier simultaneously requires large back-off power, introduce ISI in OFDM system and hence, degrade the bit error rate (BER) performance. Numerous techniques have been proposed during the period of 10 years for reducing the PAPR. The main problems regarding these techniques are computational complexity, HPA efficiency and BER performance. The main purpose of this thesis is to study and analyse the PAPR reduction techniques of the OFDM system and then to propose new scheme with low computational complexity as well as less influence on HPA efficiency and BER performance

**PRINCIPLE OF ORTHOGONALITY**:In multi-carrier system, occupied bandwidth on the channel is minimized as possible. This minimization is possible by reducing the frequency space between carriers. The narrow space among the carriers is obtained when they are orthogonal to each other. To be orthogonal, the time averaged integral product of two signals should be zero. Mathematically, the orthogonality of two signals can be expressed as-OFDM communication systems are able to effectively utilize the frequency spectrum through overlapping subcarriers. Simulation of figure (1.1) for five sub-carriers shows that sub-carriers are able to partially overlap without interfering with adjacent sub-carriers

# International Journal of Innovative Research in Science, Engineering and Technology

(A High Impact Factor, Monthly, Peer Reviewed Journal)

Visit: [www.ijirset.com](http://www.ijirset.com)

Vol. 8, Issue 8, August 2019

because the maximum power of each subcarrier corresponds directly with the minimum power of each adjacent channel. In addition, different sub-carriers are orthogonal to each other and they are totally different from one another.

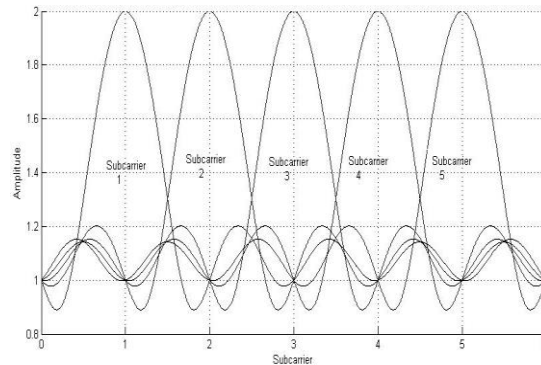

Figure-1. Frequency response of 5 sub-carriers of OFDM signal.



Fig.1. Interleaved OFDMA

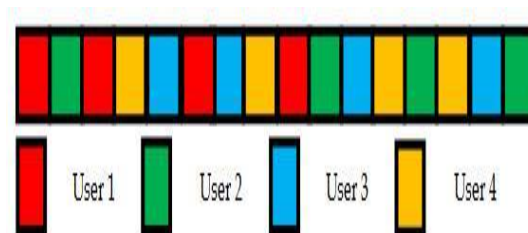

Fig.2 Random-Interleaved OFDMA

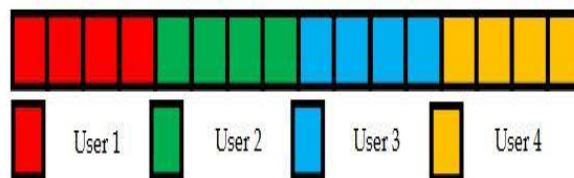

Fig.3.Localized OFDMA

OFDMA is widely adopted in the various communication standards like WiMAX, mobile broadband wireless access (MBWA), evolved UMTS terrestrial radio access (E-UTRA) and ultra mobile broadband (UMB). OFDMA is also a strong candidate for the wireless regional area networks (WRAN) and the long term evaluation advanced (LTE Advanced). However, OFDMA has some drawbacks, among others the peak-to-average power ratio (PAPR) is still one of

# International Journal of Innovative Research in Science, Engineering and Technology

(A High Impact Factor, Monthly, Peer Reviewed Journal)

Visit: [www.ijirset.com](http://www.ijirset.com)

Vol. 8, Issue 8, August 2019

the major drawbacks in the transmitted OFDMA signal (Wang & Chen, 2004). Therefore, for zero distortion of the OFDMA signal, the high-power-amplifier (HPA) must not only operate in its linear region but also with sufficient back-off. Thus, HPA with a large dynamic range is required for OFDMA systems. These amplifiers are very expensive and are major cost component of the OFDMA systems.

## II. RELATED WORK

The demand for higher data rate communication always provides the impetus for doing research in the OFDM field. One of the challenging issue of OFDM system is high peak to average power ratio (PAPR). High PAPR force the high power amplifier (HPA) to operate in non-linear region. This operation in non-linear region degrade the power efficiency of the amplifier simultaneously requires large back-off power, introduce ISI in OFDM system and hence, degrade the bit error rate (BER) performance. Numerous techniques have been proposed during the period of 10 years for reducing the PAPR. The main problems regarding these techniques are computational complexity, HPA efficiency and BER performance. The main purpose of this thesis is to study and analyse the PAPR reduction techniques of the OFDM system and then to propose new scheme with low computational complexity as well as less influence on HPA efficiency and BER performance.

**Imran Baig:** This paper studies the Peak to Average Power Ratio (PAPR) improvements in various precoding based Orthogonal Frequency Division Multiplexing (OFDM) systems. In particular, the Zadoff-Chu matrix Transform (ZCT) precoder based PAPR reduction technique is analyzed. The ZCTs are obtained from Zadoff-Chu (ZC) sequences by filling ZCT kernel row-wise or alternatively column wise. Row wise filling gives rise to Constant Envelope OFDM (CE-OFDM) system with 0 dB PAPR, while column wise filling give rise 7.8 dB, at clip rate of 10<sup>-3</sup> with system subcarriers N = 64 for QPSK modulation. However, since even CE-OFDM systems are required to operate with pulse shaping that helps in keeping out-of-band radiation low and meeting the transmission spectrum mask requirement, the PAPRs are no longer 0 dB. Therefore, in this paper, we present PAPR analysis of various precoding based OFDM systems with the popular Root Raised Cosine (RRC) pulse shaping. Simulation results show that, the ZCT Row-wise precoder based OFDM (ZCT-R-OFDM) system has lower PAPR than the ZCT Column-wise precoder based OFDM (ZCT-C-OFDM) system, the Hadamard Transform precoder based OFDM (WHT-OFDM) systems and the conventional OFDM systems.

**Pitchaya Boontra:** A high PAPR is well known as the serious problem of OFDM system because of a huge degradation of its signal quality, especially in the non-linear channel. From the reason, many PAPR reduction schemes have been proposed for solving this problem. The Partial Transmit Sequence (PTS) scheme is one of the PAPR reduction schemes which can improve the PAPR performance effectively. However, its computational complexity would be increased which is proportional to the increasing number of symbol clusters in the optimum PAPR value for a PAPR reduction process. To solve this problem, this paper proposes the PAPR reduction scheme based on the improved PTS with Artificial Bee Colony (ABC) algorithm for OFDM system. The potential capability of the proposed scheme is the PAPR reduction performance with low computational complexity which leads to the improvement of signal quality in the OFDM system. The excellent PAPR reduction performance with the low computational complexity of the proposed scheme has been verified by the computer simulations in this paper.

**Necmi Taşpınar:** In this letter, we propose a parallel artificial bee colony (P-ABC) algorithm based on a new search strategy. Performance of the P-ABC is tested for peak-to-average power ratio (PAPR) reduction problem using selected mapping (SLM) scheme in both orthogonal frequency division multiplexing (OFDM) and multiple-input multiple-output (MIMO)-OFDM systems. Moreover, standard ABC and two different modified ABC algorithms - ABC/best/1 and modified ABC/best/1 - are proposed for the SLM scheme. Simulation results show that the proposed P-ABC provides good PAPR reduction and bit-error-rate performances with low computational complexity.

**Azlina Idris:** Orthogonal Frequency Division Multiplexing (OFDM) is widely used now in Malaysia as fourth generation (4G) communication system. Even though its performance is good and sufficient for now, however there is always room for improvement in the system. The major drawback of OFDM system is Peak to Average Power Ratio (PAPR). High PAPR could affect the performance of system and it could consume more power at the receiving end which is user's

# International Journal of Innovative Research in Science, Engineering and Technology

(A High Impact Factor, Monthly, Peer Reviewed Journal)

Visit: [www.ijirset.com](http://www.ijirset.com)

Vol. 8, Issue 8, August 2019

mobile phone. Hence, researcher comes up with Filtered Orthogonal Frequency Division Multiplexing (F-OFDM) to overcome problems that arise with the use of OFDM. This research paper will overlook the performance of OFDM and F-OFDM in term of the PAPR. Two techniques from block coding that is Arithmetic code and Reed-Solomon code was used as PAPR reduction technique. Both techniques were compared and it was discovered that arithmetic technique is more suitable to be use as PAPR reduction method. This is because arithmetic successfully reduces PAPR value by up to 18.5%. Apart from that, two modulation techniques will be used to compare its effect and performance on both OFDM and F-OFDM. Desire Guel One of the major drawbacks of OFDM modulation is the large envelope fluctuations which either result in an inefficient use of high power amplifiers (HPA) or decreased transmission system performance. Peak-to-Average Power Ratio (PAPR) is a very well known measure of the envelope fluctuations and has become the cost function used to evaluate and design OFDM systems. In this paper, we propose a PAPR reduction scheme known as adding signal method for which the principle is to reduce the PAPR of the OFDM signals by adding several artificial signals. It is an extension of the method that we have proposed in. The major advantages of this technique include downward compatibility, no performance degradation and no transmission of side information. A method is said to be downward compatibility if its implementation in a transmitter does not imply modifications in the associated receiver. According to simulation results, the method outperforms the PAPR-reduction performance presented. For example, at 10<sup>-2</sup> of the Complementary Cumulative Distribution Function (CCDF), the PAPR is reduced about 3.5 dB for 5 artificial signals addition, whereas this reduction is about 1.5 dB for method which is the case of one artificial signal addition.

### III. PROPOSED

**PAPR Reduction Techniques** The random interleaved subcarrier mapping is favourable for the mobile WiMAX because it increases the capacity in the frequency selective fading channels and offers maximum frequency diversity. So, in this section, we present two precoding based random-interleaved OFDMA uplink systems for the PAPR reduction in the mobile WiMAX systems: Zadoff-Chu matrix transforms (ZCMT) precoding based random-interleaved OFDMA uplink system and SLM based ZCMT precoded random-interleaved OFDMA uplink system. The PAPR of the proposed system is analyzed with root-raised-cosine (RRC) pulse shaping.

**PRECODING METHOD:** proposed method reduces the PAPR of OFDM system by using pulse shaping. The PAPR of OFDM signal can be made very close to that of single carrier signal with the use of pulse shaping. Pulse shaping is used to shape the spectrum of the transmitted signal as well as to reduce PAPR. This technique is flexible and it can control the correlation between the OFDM block samples without destroying the orthogonality property between the subcarriers of the modulated signal. This technique can be used for OFDM and Discrete Multi-Tone (DMT) transmission.

**ZADOFF-CHU SEQUENCES:** Zadoff-Chu sequences are the class of polyphase sequences having optimum correlation properties. These sequences have an ideal periodic autocorrelation, constant magnitude and circular auto-orthogonality. The constant envelope feature of the Zadoff-Chu sequences can greatly alleviate the annoying peak-to-average power (PAPR) problem occurred in orthogonal frequency division multiplexing (OFDM) systems. According to (Chu, 1972; Popovic', 1997), Zadoff-Chu sequences of length N can be defined as follows:-Where  $k=0,1,2,\dots,N-1$ , q is any integer, r is any integer relatively prime to N.

**CONSTANT ENVELOPE PROPERTY AFTER IDFT:**The Zadoff-Chu sequences have constant amplitude, and its IDFT has also constant amplitude. Additionally, zadoff-chu sequence is also Zadoff-Chu sequence after FFT or IFFT. Orthogonality Property The DFT of the Zadoff-Chu sequences equal to the conjugate of the Zadoff-chu sequences as follows:-Therefore, the orthogonality in time domain as well as in frequency domain is preserved.

**ZADOFF-CHU MATRIX TRANSFORM (ZCMT):** Zadoff-Chu matrix transform (ZCMT) is used to lower the correlation relationship of the IFFT input sequence. The ZCMT precoding matrix must accomplish the following criteria:- All the elements of the precoding matrix must have the identical magnitude. The magnitude must be equal to:1. ZCMT precoding matrix must be non-singular. The first condition guarantees that each output symbol has the same quantity of information of every input data. The second requirement preserves the power at the precoder output. Finally, the third

# International Journal of Innovative Research in Science, Engineering and Technology

(A High Impact Factor, Monthly, Peer Reviewed Journal)

Visit: [www.ijirset.com](http://www.ijirset.com)

Vol. 8, Issue 8, August 2019

requirement ensures the recovery of the original data at the receiver. The kernel of the ZCMT is defined in equation . For  $N=L \times L$  and  $j$ , the ZCMT kernel

**ZCT PRECODING MODEL:** Zadoff-Chu codes are the special case of the generalized Chip-Like polyphase sequences having optimum correlation properties. Zadoff-Chu sequences have an ideal periodic conditions. In the ZCT precoded OFDM systems, the baseband modulated data is passed through S/P converter which generates a complex vector of size  $L$  that can be written as  $X = [X_0, X_1, X_2 \dots X_{L-1}]$ . Then ZCT precoding is applied to this complex vector which transforms this complex vector into new vector of same length

## ZCMT PRECODING BASED RANDOM INTERLEAVED OFDMA SYSTEM

Fig.4 shows a ZCMT precoding based random-interleaved OFDMA uplink system. In this system a precoding matrix  $Z$  of dimension  $N=L \times L$  is applied to constellations symbols before the subcarrier mapping and IFFT to reduce the PAPR. In the ZCMT precoding based random-interleaved OFDMA systems, baseband modulated data is passed through S/P convertor which generates a complex vector of size  $M$  that can be written as follows:-

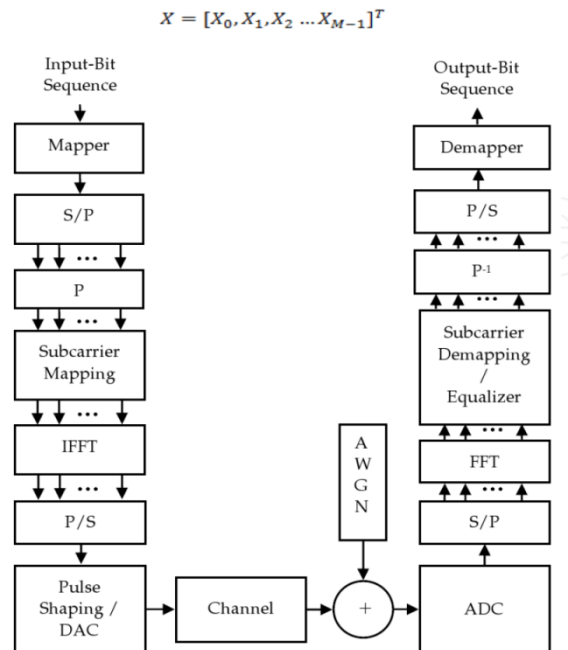

Fig.4 ZCMT Precoding based Random Interleaved OFDMA Uplink System

Then ZCMT precoding is applied to this complex vector which transforms this complex vector into new vector of same length  $L$  that can be written as follows:- Where  $Z$  is a precoder matrix of size  $N=L \times L$

## IV. CONCLUSION

The rapid development of OFDM system begins after the implementation of DFT instead of bank of modulators as given by Weinstein and Ebert in 1971. Recently, it is widely exploited by wireless communication standards like IEEE 802.11 a/g/n standards, DAB, DVB, MC-CDMA and WiMAX. In this work, a PAPR reduction technique for the UFOFDM and the F-OFDM modulation schemes was proposed. This technique has to keep the spectral efficiency and

## International Journal of Innovative Research in Science, Engineering and Technology

(A High Impact Factor, Monthly, Peer Reviewed Journal)

Visit: [www.ijirset.com](http://www.ijirset.com)

Vol. 8, Issue 8, August 2019

the BER performance of the system. For this reason, a precoding based PAPR reduction technique was proposed. This technique transforms the F-OFDM signal to a single carrier signal and the UF-OFDM to a multicarrier signal with smaller number of carriers. At the receiver, the received symbols can be decoded without the need of sending any “side information” and consequently without reducing the spectral efficiency. In addition to the PAPR and the PA output PSD tails reductions, this method conserves the BER in an AWGN channel. Further studies will be performed in the upcoming works about their BER performance in a frequency selective channel.

### REFERENCES

1. A new ZCT precoded OFDM system with pulse shaping: PAPR analysis Imran Baig Varun Jeoti 2010 IEEE Asia Pacific Conference on Circuits and Systems Year: 2010
2. A PAPR Reduction Scheme based on Improved PTS with ABC Algorithm for OFDM Signal Tanairat Mata ; Pisit Boonsrimuang ; Pitchaya Boontra 2018 15th International Conference on Electrical Engineering/Electronics, Computer, Telecommunications and Information Technology (ECTI-CON) Year: 2018
3. A Novel Parallel Artificial Bee Colony Algorithm and Its PAPR Reduction Performance Using SLM Scheme in OFDM and MIMO-OFDM Systems Necmi Taşpınar ; Mahmut Yıldırım IEEE Communications Letters Year: 2015 Volume: 19, Issue: 10 |
4. Reduction of PAPR Using Block Coding Method and APSK Modulation Techniques for F-OFDM in 5G System Azlina Idris ; Nur Lisa Mohd Sapari ; Mohd Syarhan Idris ; Suzie Seroja Sarnin ; Wan Norsyafizan Wan Mohamad ; Nani Fadzlina Naim TENCN 2018 - 2018
5. Artificial signals addition for reducing PAPR of OFDM systems Desire Guel ; Jacques Palicot 2008 IEEE International Symposium on Signal Processing and Information Technology Year: 2008
6. PAPR Analysis of Class-III SLM Scheme Based on Variance of Correlation of Alternative OFDM Signal Sequences Jun-Young Woo ; Hyun Seung Joo ; Kee-Hoon Kim ; Jong-Seon No ; Dong-Joon Shin IEEE Communications Letters Year: 2015 | Volume: 19, Issue: 6
7. A Modified SLM Scheme With Low Complexity for PAPR Reduction of OFDM Systems Seok-Joong Heo ; Hyung-Suk Noh ; Jong-Seon No ; Dong-Joon Shin IEEE Transactions on Broadcasting Year: 2007 | Volume: 53, Issue: 4
8. Precoding PTS scheme for PAPR reduction in OFDM Thota Sravanti ; N Vasantha 2017 International Conference on Innovations in Electrical, Electronics, Instrumentation and Media Technology (ICEEIMT) Year: 2017
9. S.B. Weinstein and P.M. Ebert, “Data Transmission by Frequency-Division Multiplexing Using the Discrete Fourier Transform,” IEEE Transactions on Communication. Tech., vol. 19, pp. 628-634 October 1971.
10. L. j. Cimini jr “Analysis and simulation of a digital mobile channel using orthogonal frequency division multiplexing,” IEEE Transactions communication, vol. 33, pp. 665-675, July 1985.
11. P. S. Chow, J. C. Tu and J. M. Cioffi, “Performance evaluation of a multichannel System for ADSL and VHDSL services,” IEEE Selected Area, vol., SAC-9, no. 6, pp.909-91, August 1991.
12. T. Jiang, W. Xiang, H. H. Chen and Q. Ni, “Multicast broadcasting services support in OFDMA-based WiMAX systems,” IEEE Communications Magazine, vol. 45, no. 8, pp. 78–86, Aug. 2007.