

International Journal of Innovative Research in Science, Engineering and Technology

(A High Impact Factor, Monthly, Peer Reviewed Journal)

Visit: www.ijirset.com

Vol. 8, Issue 12, December 2019

Error and Efficiency Analysis of Massive 5G Technology with Different QAM Modulation

Himani Sharma¹, Prof. Meha Shrivastava², Prof. Rajesh Sharma³

M. Tech. Scholar, Department of Electronics and Communication Engg., Truba, Bhopal, India¹

Head of Dept., Department of Electronics and Communication Engg., Truba, Bhopal, India²

Assistant Professor, Department of Electronics and Communication Engg., Truba, Bhopal, India³

ABSTRACT: The fifth generation of mobile communication systems (5G) promises unprecedented levels of connectivity and quality of service (QoS) to satisfy the incessant growth in the number of mobile smart devices and the huge increase in data demand. One of the primary ways 5G network technology will be accomplished is through network densification, namely increasing the number of antennas per site and deploying smaller and smaller cells. Massive MIMO, where MIMO stands for multiple-input multiple-output, is widely expected to be a key enabler of 5G. This technology leverages an aggressive spatial multiplexing, from using a large number of transmitting/receiving antennas, to multiply the capacity of a wireless channel. The access points (Aps) are connected, through a fronthaul network, to a central processing unit (CPU) which is responsible for coordinating the coherent joint transmission. Such a distributed architecture provides additional macro-diversity, and the co-processing at multiple APs entirely suppresses the inter-cell interference. Depending on slow/fast channel fading conditions, several authors suggested adaptive LMS, RLS and NLMS based channel estimators, which either require statistical information of the channel or are not efficient enough in terms of performance or computations. In order to overcome the above effects, the work focuses on the QR-RLS based channel estimation method for Massive MIMO systems with different modulation scheme.

KEYWORDS: Massive MIMO, Channel State Information, Square Root-Recursive Least Square (QR-RLS), QAM Modulation

I. INTRODUCTION

MIMO technology has been a topic of interest for the past two decades and MU-MIMO has made its way into standards such as 4G LTE and IEEE 802.11 (WiFi). Massive MIMO is a variant of MU-MIMO with the potential to offer significantly higher spectral and energy efficiencies at low computational complexities, making it one of the enabling technologies for 5G communication systems. Nowadays, wireless communication plays a central role in the industrial production process. Ubiquitous coverage, low latency, ultra-reliable communication, and resilience are key for wireless communications in a factory environment. In this respect, “cell-free” Massive MIMO, with its flexible distributed architecture, with its macro-diversity gain and inherent ability to suppress interference, is suitable to cope with the challenging industrial indoor scenario [2]. Also, a radio stripe deployment may integrate additional sensors/actuators such as temperature sensors, microphones, miniature speakers, vibration sensors, etc., and provide additional important features, e.g., fire alarm, burglar alarm, earthquake warning, indoor positioning, climate monitoring and control.

II. CHANNEL ESTIMATION

In order to achieve the benefits of a large antenna array, accurate and timely acquisition of Channel State Information (CSI) is needed at the BS. The need for CSI is to process the received signal at BS as well as to design a precoder for optimal selection of a group of users who are served on the same time-frequency resources. The acquisition of CSI at the BS can be done either through feedback or channel reciprocity schemes based on Time Division Duplex (TDD) or

International Journal of Innovative Research in Science, Engineering and Technology

(A High Impact Factor, Monthly, Peer Reviewed Journal)

Visit: www.ijirset.com

Vol. 8, Issue 12, December 2019

Frequency Division Duplex (FDD) system. The procedure for acquiring CSI and data transmission for both systems is explained in the subsequent sections.

Channel Estimation and Data Transmission in FDD System

In FDD system, the signals are transmitted at different frequency band for uplink and downlink transmission. Therefore, CSI for the uplink and downlink channels are not reciprocal. Hence, to generate precoding/beamforming vector for each user, BS transmits a pilot signal to all users in the cell and then all users' feedback estimated CSI of the downlink channels to the BS as shown in Fig. 1. During uplink transmission, BS needs CSI to decode the signal transmitted by the users. To detect the signal transmitted by the user, CSI is acquired by sending pilot signal in the uplink transmission.

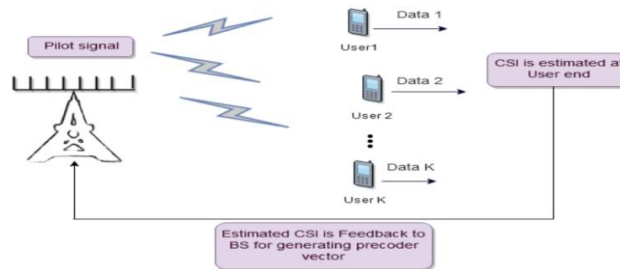

Figure 1: Downlink transmission in an FDD Massive MIMO system

III. PROPOSED METHODOLOGY

The MIMO-OFDM device modified into applied with the useful resource of MATLAB/SIMULINK. The execution device is binary facts this is modulated the use of QAM and mapped into the constellation elements.

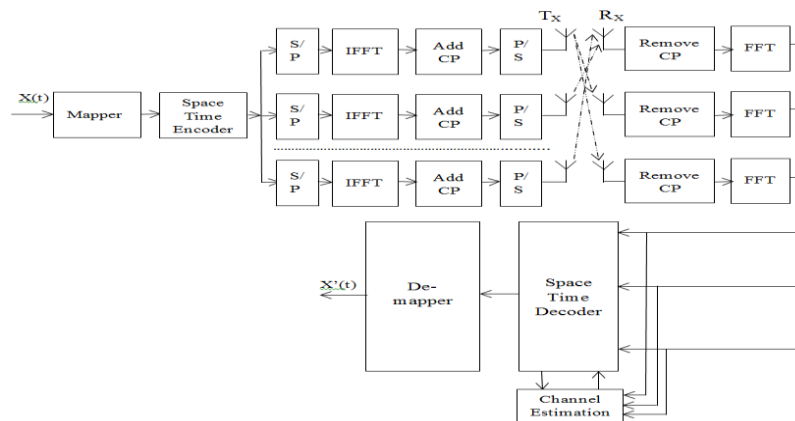

Figure 2: Massive MIMO System Models with Channel Estimation Technique

The virtual modulation scheme will transmit the records in parallel by means of manner of assigning symbols to every sub channel and the modulation scheme will determine the phase mapping of sub-channels thru a complex I-Q mapping vector show in figure 2. The complicated parallel facts stream must be converted into an analogue signal this is suitable to the transmission channel.

The complicated parallel facts stream has to be transformed into an analogue sign that is suitable to the transmission channel. It is performed to the cyclic prefix add to the baseband modulation signal because the baseband signal is not overlap. After than the signal is splitter the two or more part according to the requirement.

International Journal of Innovative Research in Science, Engineering and Technology

(A High Impact Factor, Monthly, Peer Reviewed Journal)

Visit: www.ijirset.com

Vol. 8, Issue 12, December 2019

Square Root Recursive Least Square (QR-RLS) Algorithm

A QR-RLS based MIMO-OFDM channel estimation is proposed. Which uses given rotation based QR factorization for estimator updating. Channel estimation is a center issue for recipient plan in remote correspondences frameworks. Since it is unimaginable to expect to quantify each remote direct in the field, it is critical to utilize preparing arrangements to appraise channel parameters, for example, constrictions and deferrals of the proliferation way. Since in most UWB recipients associate the got flag with corresponded a predefined format flag, an earlier learning of the remote channel parameters is important to foresee the state of the layout flag that matches the got flag.

Different Modulation Technique:-

Binary Phase Shift Keying (BPSK) is a two phase modulation scheme, where the 0's and 1's in a binary message are represented by two different phase states in the carrier signal: $\theta=0^\circ$ for binary 1 and $\theta=180^\circ$ for binary 0.

Quadrature Amplitude Modulation (QAM)

Many data transmission systems migrate between the different orders of QAM, 16-QAM, 32-QAM and 64-QAM, dependent upon the link conditions. If there is a good margin, higher orders of QAM can be used to gain a faster data rate, but if the link deteriorates, lower orders are used to preserve the noise margin and ensure that a low bit error rate is preserved.

As the QAM order increases, so the distance between the different points on the constellation diagram decreases and there is a higher possibility of data errors being introduced. To utilize the high order QAM formats, the link must have a very good E_b/N_0 otherwise data errors will be present. When the E_b/N_0 deteriorate, then other the power level must be increased, or the QAM order reduced if the bit error rate is to be preserved.

IV. SIMULATION RESULT

MATLAB simulations are performed for various combinations of transmitted and received antenna in massive MIMO system. Simulation experiments are conducted to evaluate the SNR verse bit error rate (BER) performance of the proposed QR-RLS based channel estimation with different modulation technique i.e. QAM-16, QAM-32 and QAM-64 for 8×8 system is shown in figure 3. For different value of SNR, the implemented QR-RLS based channel estimation for 8×8 system shows BER reduction performance.

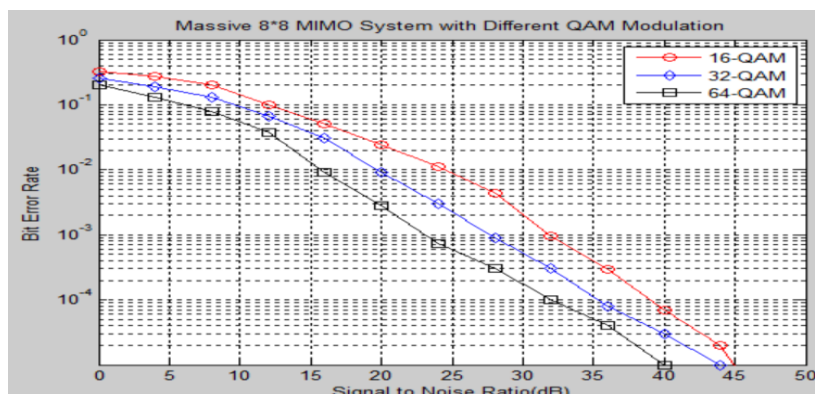

Figure 3: BER vs SNR for Massive 8×8 System with QR-RLS based Channel Estimation Technique

Simulation experiments are conducted to evaluate the SNR VS BER performance of the proposed algorithm 16×16 system is shown in figure 4.

International Journal of Innovative Research in Science, Engineering and Technology

(A High Impact Factor, Monthly, Peer Reviewed Journal)

Visit: www.ijirset.com

Vol. 8, Issue 12, December 2019

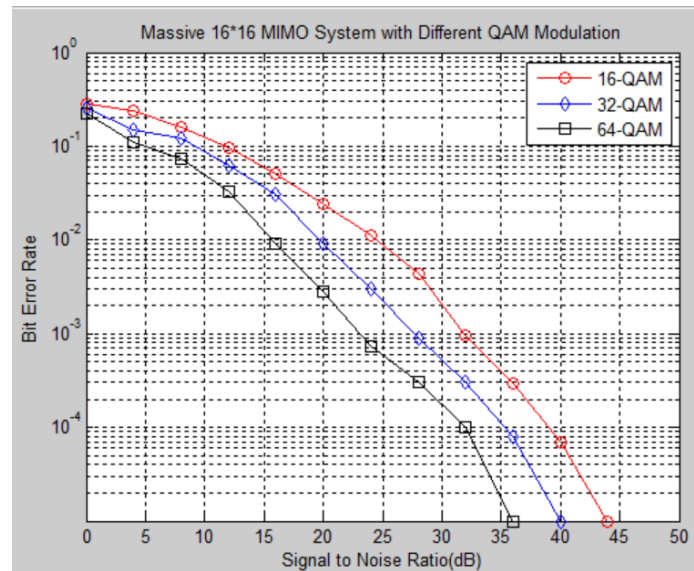

Figure 4: BER vs SNR for Massive 16×16 System with QR-RLS based Channel Estimation Technique

Simulation experiments are conducted to evaluate the SNR VS BER performance of the proposed algorithm 32×32 system is shown in figure 5.

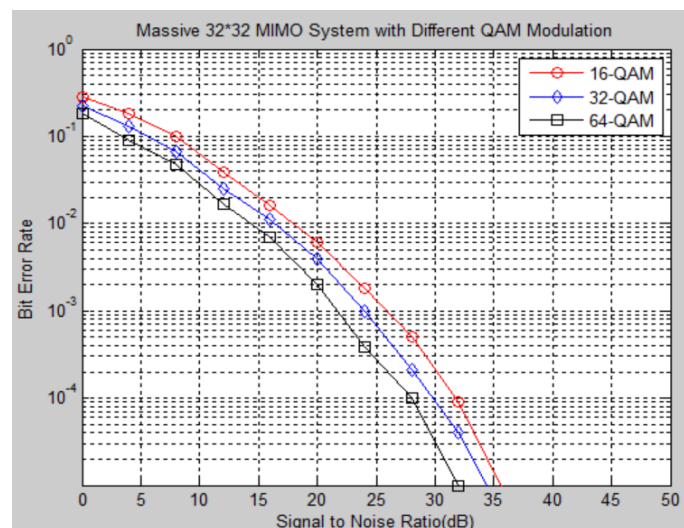

Figure 5: BER vs SNR for Massive 32×32 System with QR-RLS based Channel Estimation Technique

Simulation experiments are conducted to evaluate the SNR verse spectrum efficiency performance of the proposed QR-RLS based channel estimation with different modulation technique i.e. QAM-16, QAM-32 and QAM-64 for 8×8 system is shown in figure 6.

International Journal of Innovative Research in Science, Engineering and Technology

(A High Impact Factor, Monthly, Peer Reviewed Journal)

Visit: www.ijirset.com

Vol. 8, Issue 12, December 2019

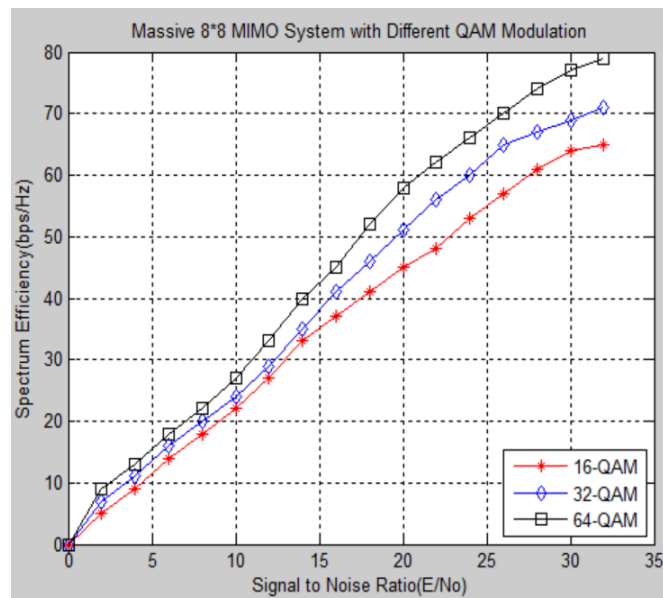

Figure 6: Spectrum Efficiency vs SNR for Massive 8×8 System with QR-RLS based Channel Estimation Technique

V. CONCLUSION

We have developed a method for tracking the error for receiver side with knowing the transmit pre-coder or data. The proposed method is particularly useful in minimize the error in receiver side. The proposed QR-RLS based channel estimation technique with different QAM modulation technique is applied for different transmitter and receiver antenna and calculated bit error rate (BER) and spectrum efficiency with respect to signal to noise ratio (SNR). Simulation result is clear that the 32×32 transmitter and receiver antenna is best performance compared to 16×16, 8×8 transmitter and receiver antenna.

REFERENCES

- [1] H. Q. Ngo A. Ashikhmin H. Yang E. G. Larsson T. L. Marzetta "Cell-free massive MIMO versus small cells" IEEE Trans. Wireless Communication vol. 16 no. 3 pp. 1834-1850 Mar. 2017.
- [2] Huang A. Burr "Compute-and-forward in cell-free massive MIMO: Great performance with low backhaul load" Proc. IEEE Int. Conf. Communication (ICC) pp. 601-606 May 2017.
- [3] H. Al-Hraishawi, G. Amarasuriya, and R. F. Schaefer, "Secure communication in underlay cognitive massive MIMO systems with pilot contamination," in In Proc. IEEE Global Communication Conf. (Globecom), pp. 1-7, Dec. 2017.
- [4] V. D. Nguyen et al., "Enhancing PHY security of cooperative cognitive radio multicast communications," IEEE Trans. Cognitive Communication and Networking, vol. 3, no. 4, pp. 599-613, Dec. 2017.
- [5] R. Zhao, Y. Yuan, L. Fan, and Y. C. He, "Secrecy performance analysis of cognitive decode-and-forward relay networks in Nakagami-m fading channels," IEEE Trans. Communication, vol. 65, no. 2, pp. 549-563, Feb. 2017.
- [6] W. Zhu, J. and. Xu and N. Wang, "Secure massive MIMO systems with limited RF chains," IEEE Trans. Veh. Technol., vol. 66, no. 6, pp. 5455-5460, Jun. 2017.
- [7] R. Zhang, X. Cheng, and L. Yang, "Cooperation via spectrum sharing for physical layer security in device-to-device communications under laying cellular networks," IEEE Trans. Wireless Communication, vol. 15, no. 8, pp. 5651-5663, Aug. 2016.
- [8] K. Tourki and M. O. Hasna, "A collaboration incentive exploiting the primary-secondary systems cross interference for PHY security enhancement," IEEE J. Sel. Topics Signal Process., vol. 10, no. 8, pp. 1346-1358, Dec 2016.
- [9] T. Zhang et al., "Secure transmission in cognitive MIMO relaying networks with outdated channel state information," IEEE Access, vol. 4, pp. 8212-8224, Sep. 2016.
- [10] Y. Huang et al., "Secure transmission in spectrum sharing MIMO channels with generalized antenna selection over Nakagami-m channels," IEEE Access, vol. 4, pp. 4058-4065, Jul. 2016.

International Journal of Innovative Research in Science, Engineering and Technology

(A High Impact Factor, Monthly, Peer Reviewed Journal)

Visit: www.ijirset.com

Vol. 8, Issue 12, December 2019

- [11] Y. Deng et al., "Artificial-noise aided secure transmission in large scale spectrum sharing networks," IEEE Trans. Communication, vol. 64, no. 5, pp. 2116–2129, May 2016.
- [12] J. Zhu, R. Schober, and V. K. Bhargava, "Linear precoding of data and artificial noise in secure massive MIMO systems," IEEE Trans. Wireless Communication, vol. 15, no. 3, pp. 2245–2261, Mar. 2016.
- [13] K. Guo, Y. Guo, and G. Ascheid, "Security-constrained power allocation in MU-massive-MIMO with distributed antennas," IEEE Trans. Wireless Commun., vol. 15, no. 12, pp. 8139–8153, Dec. 2016.
- [14] Supraja Eduru and Nakkeeran Rangaswamy, "BER Analysis of Massive MIMO Systems under Correlated Rayleigh Fading Channel", 9th ICCNT IEEE 2018, IISC, Bengaluru, India.
- [15] R. Prasad, C. R. Murthy, B. D. Rao, "Joint approximately sparse channel estimation and data detection in OFDM systems using sparse Bayesian learning", IEEE Trans. Signal Process., vol. 62, no. 14, pp. 3591–3603, Jul. 2014.
- [16] Mel Li, Xiang Wang and Kun Zhang, "Comparative Study of Adaptive Filter Channel Estimation Technique in MIMO-OFDM System Based on STBC", Proceedings of the 2014 International Conference on Machine Learning and Cybernetics, Lanzhou, 13-16 July, 2014.
- [17] Muhammet Nuri Seyman and Necmi Taspmar, "Channel estimation based on neural network in space time block coded MIMO-OFDM system", Digital Signal Processing, Vol. 23, No.1, pp. 275-280, Jan. 2013.
- [18] Biswajit Sahoo, Ravi Ranjan Prasad, and P. Samundiswary, "BER Analysis of Mobile WiMAX System using LDPC Coding and MIMO System under Rayleigh Channel", International conference on Communication and Signal Processing, April 3-5, 2013, India.
- [19] Li Mei, Wang Xiang, Zhang Xiaoming, Jia Ke. "RLS and its improved algorithms in MIMO-OFDM System", International Journal of Modelling, Identification and Control, Vol. 16, No. 3, pp. 246-250, Jul. 2012.
- [20] P. Mukunthan and, P. Dananjayan, "PAPR Reduction based on a Modified PTS with Interleaving and Pulse Shaping method for STBC MIMO-OFDM System", IEEE International Conference Coimbatore, July 2012.
- [21] Wei Jiang and Daoben Li, "Convolutional Multi-code Multiplexing for OFDM Systems", Beijing University of Posts and Telecommunications Beijing, pp. 6432-6439, IEEE 2012.
- [22] L. Yang, K. K. Soo, S. li, and Y. M. SU, "PAPR Reduction Using Low Complexity PTS to Construct of OFDM Signals Without Side Information", IEEE Transactions on Broadcasting, Vol. 57, No. 2, pp. 4532-4539, June 2011.
- [23] Chin-Liang Wang and Shun-Sheng Wang† and Hsiao-Ling Chang, "A Low-Complexity SLM Based PAPR Reduction Scheme for SFBC MIMO-OFDM Systems", International Conference on Wireless Communication, pp. 345-352, 2011 IEEE.
- [24] Divyang Rawal, Park Youn Ok and C. Vijaykumar, "A Novel training based QR-RLS channel estimator for MIMO OFDM systems", Wireless Advanced (WiAD), 6th Conference on, IEEE 2010.
- [25] Ke Chen and Xiaojing Huang, "A Novel Approach for Interference Suppression in Multi-Sub band Convolutional Coded OFDM System", School of Electrical, Computer & Telecommunications University of Wollongong, Australia, 2010.