

Operating Cost Reduction by Replacing Heater in Booster Unit

Mr.J.Jaison¹, Mr.J.Jose Priston², Mr.P.John Rabindranath³, Mr.A.kiruba Samraj⁴, Mr.F.Elsin Raja⁵
Assistant Professor, Department of Mechanical Engineering, Francis Xavier Engineering College, Vannarpet,
Tirunelveli, Tamil Nadu, India¹

Students, Department of Mechanical Engineering, Francis Xavier Engineering College, Vannarpet, Tirunelveli,
Tamil Nadu, India^{2,3,4&5}

ABSTRACT:In DCW, It contain a captive power plant (Diesel power plant), in that furnace oil is used instead of diesel fuel for that it contain a booster unit, which consists of deaerator, electrical heater, temperature sensor, and viscometer and control unit. Generally in the booster unit, electrical heaters are used for maintaining the temperature of the fuel (HFO). It consumes more electrical power and the operating cost is high and also it affects the company's profit. To overcome the drawback, we substitute steam heater instead of electrical heater. So that electricity cost was totally reduced and also utilised the steam from the co-generative power plant.

I. INTRODUCTION

Captive power plant in DCW consists of two wartsila diesel engines of model 18v32, that is 18 cylinders, v-type and 32cm bore diameter. Each engine produces of 6MW. The engines are supplied with furnace oil for producing power. As we are supplying furnace oil for power generation, we could not able to produce power at initial conditions, so we are applying lube oil continuously in order to keep the engine parts at warm conditions. CPP in DCW functions only when there is a failure in cogen power plant. But the wartsila diesel engines are supplied with the lube oil at all times the furnace oil used here for power generation consists of many foreign items and high viscosity. So we are using many units to filter the foreign matters and to reduce its viscosity. One of the units is booster unit which consists of an electrical heater. Our aim is to replace the electrical heater by steam heater and hence to reduce the operating cost.



Figure 1.1 wartsila diesel engine

International Journal of Innovative Research in Science, Engineering and Technology

(A High Impact Factor, Monthly, Peer Reviewed Journal)

Visit: www.ijirset.com

Vol. 8, Issue 3, March 2019

A Booster unit which consists of a deaerator, electrical heater, temperature sensor and a control unit. Initially the furnace oil enters the deaerator where the air is removed and it is pumped to the electrical heater and it is heated to a certain temperature controlled by the temperature sensor and the control unit. Our aim is to implement a steam heater in the place of electrical heater by using a bypass valve.

The booster unit is used for pressurizing, cleaning, conditioning and feeding the fuel from the service tanks the engines. The booster part of the oil treatment unit is must is designed to full fill diesel engine suppliers requirements concerning the fuel circulations capacity, supply pressure, viscosity/temperature and filtration fineness.

Captive power plant in DCW consists of two wartsila diesel engines of model 18v32. Where,18-cylinders, v-type, 32cm bore diameter, Each engine produces a power of 6MW. In that we used this for furnace oil instead of diesel fuel.

II. PROPOSED MODEL

EXISTING MODEL:

In the existing model, electric heater is placed in the booster unit and flow property of furnace oil was control by viscometer. Here we have the block diagram of the entire unit.

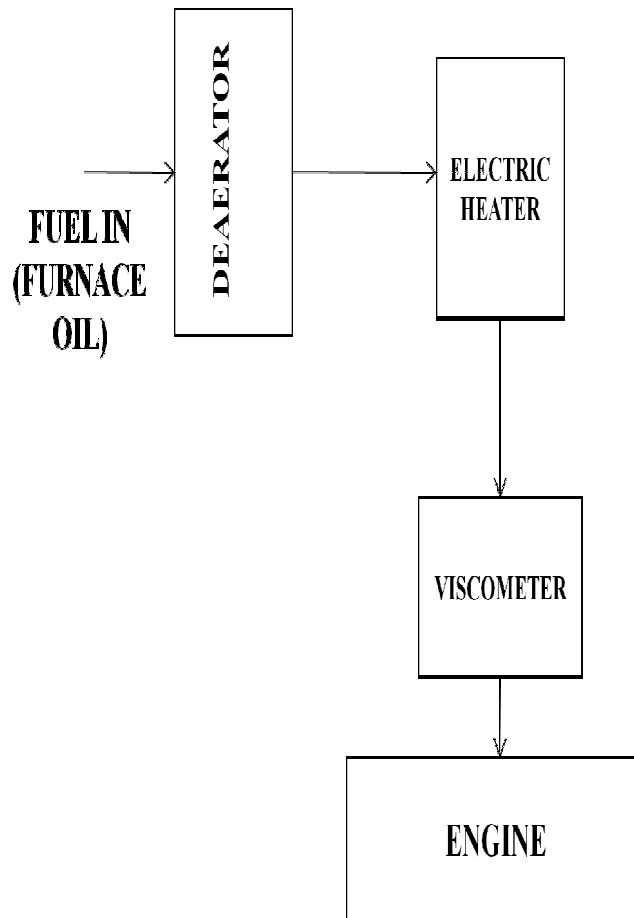

Fig 2.1 Existing Model

International Journal of Innovative Research in Science, Engineering and Technology

(A High Impact Factor, Monthly, Peer Reviewed Journal)

Visit: www.ijirset.com

Vol. 8, Issue 3, March 2019

FINAL MODEL:

This our final setup of our project , to design a steam heater for the system in the booster unit. we substitute steam heater instead of electrical heater. So that electricity cost was totally reduced and also utilised the steam from the co-generative power plant.

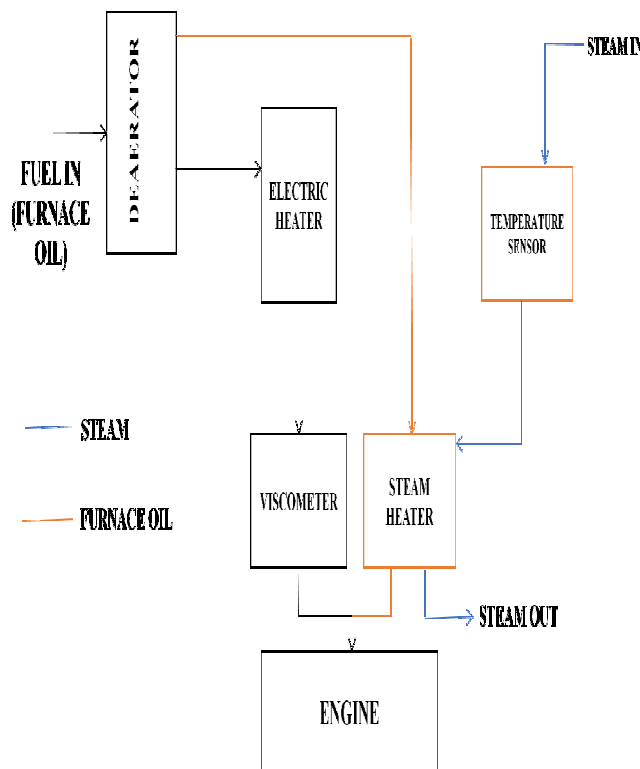

Fig 2.2 Final model

Using electrical heater in the booster unit, the electricity cost and other wages becomes very high, so we are going on for a steam heater to reduce the cost.

In open gravity steam heating systems water is heated to its boiling point 100F (2120C) and steam rises by convection through pipes to heat exchangers located throughout the building, displacing the air in the pipes and radiators.

It is similar to a hot water boiler system but operates at a higher temperature. Unlike a hot water system, there is no pressure reducing valve or expansion tank. Instead there is an automatic safety control and pressure gauge.

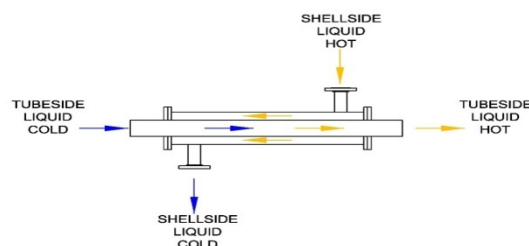

Fig2.3 Counter flow

International Journal of Innovative Research in Science, Engineering and Technology

(A High Impact Factor, Monthly, Peer Reviewed Journal)

Visit: www.ijirset.com

Vol. 8, Issue 3, March 2019

III. MODEL OF STEAM HEATER

Steam is one of the most common and effective heat transfer mediums used in industry, but it is not the only medium available. Other fluids such as hot water and oil are also used for indirect heating in heat exchangers. The following series of articles will focus on the advantages of using steam compared to hot water or oil for heating. Due to a large number of heat exchanger configurations a classification system as devised based upon the basic operation, construction, heat transfer and flow arrangement

COUNTER FLOW EXCHANGER:

In a counter flow exchanger or concurrent exchanger two fluids flows parallel to each other but in opposite direction within a core. Temperature parallel of the two fluids in such as exchanger may be idealized as one dimensional the counter flow arrangement is thermodynamically superior.

It is a most efficient flow arrangement producing the highest temperature change in each fluid compared to any other two fluid flow arrangements for a given overall thermal conductance fluid flow rate and fluid inlet temperature

Heat exchanger is device used to transfer heat between two or more fluid system at different temperatures. Heat exchanger find wide spread use in power generation, chemical processing, electronic cooling, air conditioning, refrigeration, and automotive application. An important design aspect of heat exchanger technology is the selection of appropriate materials to conduct and transfer heat fast and efficiently.

Copper has many desirable properties for many thermally efficient and durable heat exchangers. First and foremost copper is the excellent conductor of heat. This mean that copper high thermal conductivity allow heat to pass quickly.

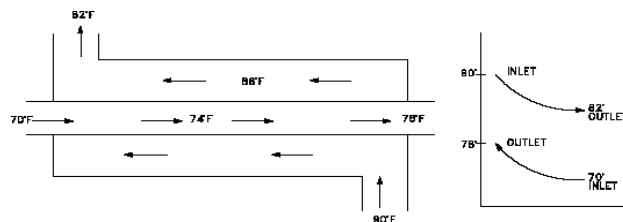

Fig 3.1 Side view

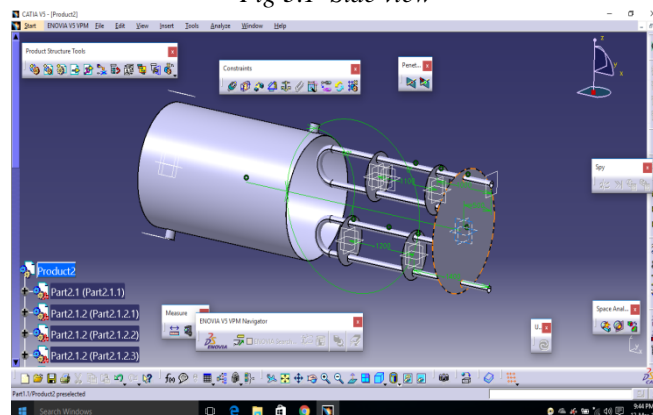

Fig 3.2 Side view

International Journal of Innovative Research in Science, Engineering and Technology

(A High Impact Factor, Monthly, Peer Reviewed Journal)

Visit: www.ijirset.com

Vol. 8, Issue 3, March 2019

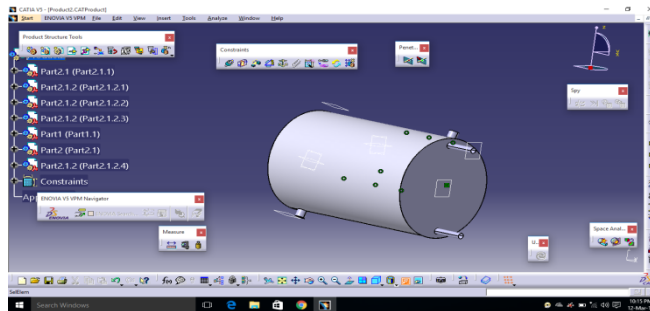
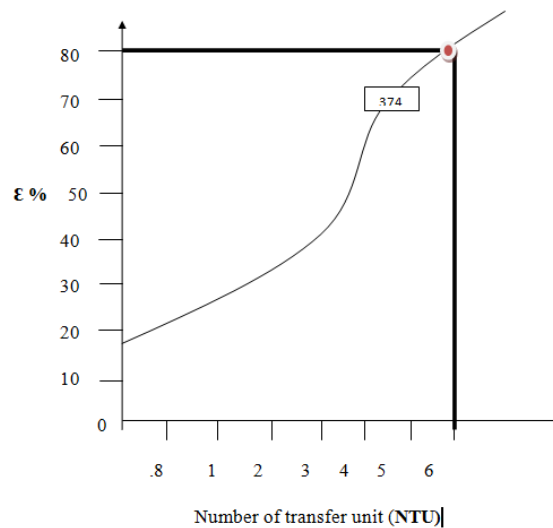

Fig 3.3 Cover view

EFFECTIVENESS



Effectiveness , $\epsilon = 84\%$

IV. CONCLUSION

Thus the design of steam heater is done and implemented successfully. The steam heater is replaced instead of electric heater in the booster unit of captive power plant in dharangadara chemical works Ltd, and operating cost of the captive power plant is considerably reduced. This made the power plant to run more efficiently when compared to previously use electric heater in the booster unit.

International Journal of Innovative Research in Science, Engineering and Technology

(A High Impact Factor, Monthly, Peer Reviewed Journal)

Visit: www.ijirset.com

Vol. 8, Issue 3, March 2019

REFERENCES

- [1] Jianliua , “The classification of the heat exchangers and theory research”(Nov 2017)
- [2] Stephen raj, sathiskumar “Design and analysis of heat exchanger for maximum heat transfer rate”
- [3] Bhushan. S, Waghchaure, V.P , Ate “Review on experimental analysis of heat transfer in shell and twisted tube heat exchanger”(AUG 2016)
- [4]Ravi kumar ,Banjare , Prakashkumarsen ,GopalSahum “A paper on the analysis of effect of material used in heat exchanger and its performances”(OCT 2015)
- [5] Arturo Reyes-leon , CelerinoResendiz-Rosas “The design of heat exchangers”
- [6] A.Mohan , P. Sankar, S. Ramesh , M.Sathish “CFD Analysis of double pipe heat exchanger with and without dimples”
- [7] R.Ramakanth ,k.Karika , P.Varasha , T. Likhitha “Review on shell and tube heat exchangers using helical baffles and non fluids”
- [8] Prof. S. Y. Sawant, Mr.Sagar E. More“Experimental analysis of advanced materials for Anticorrosive Heat Exchanger”
- [9] Prabhat Gupta, M.D. Atrey, “Performance evaluation of counter flow heat exchangers considering the effect of heat in leak and longitudinal conduction for low-temperature applications”.
- [10] AURUBIS Heat Exchanger Material.
- [11] A. Sommers, Q. Wang, X. Han, C. T'Joen, Y.Park, A. Jacobi, “Ceramics and ceramicmatrix composites for heat exchangers in advanced thermal systems A review”.2006), asme.org.