

Underground Soil Communication by Wireless Underground Sensor Network (WUSN)

S. Jeya Anusuya, G.Bhavani, R.Sugantha Devi, G.swatha, S.Vanitha

Associate Professor, Department of Electronics and Communication Engineering, T.J.S Engineering College,
Peruvoyal, India

Assistant Professor, Department of Electronics and Communication Engineering, T.J.S Engineering College,
Peruvoyal, India

Student, Department of Electronics and Communication Engineering, T.J.S Engineering College, Peruvoyal, India

Student, Department of Electronics and Communication Engineering, T.J.S Engineering College, Peruvoyal, India

Student, Department of Electronics and Communication Engineering, T.J.S Engineering College, Peruvoyal, India

ABSTRACT: This work introduces the concept of a Wireless Underground Sensor Network (WUSN). WUSNs can be used to monitor a variety of conditions, such as soil properties for agricultural applications and toxic substances for environmental monitoring. Unlike existing methods of monitoring underground conditions, which rely on buried sensors connected via wire to the surface, WUSN devices are deployed completely belowground and do not require any wired connections. Each device contains all necessary sensors, memory, a processor, a radio, an antenna, and a power source. This makes their deployment much simpler than existing underground sensing solutions. Wireless communication within a dense substance such as soil or rock is, however, significantly more challenging than through air. This factor, combined with the necessity to conserve energy due to the difficulty of unearthing and recharging WUSN devices, requires that communication protocols be redesigned to be as efficient as possible. This work provides an extensive overview of applications and design challenges for WUSNs, challenges for the underground communication channel including methods for predicting path losses in an underground link, and challenges at each layer of the communication protocol stack.

I.INTRODUCTION

Wireless Underground Sensor Networks (WUSNs), which consist of wireless sensors buried underground, are a natural extension of the wireless sensor network phenomenon and have been considered as a potential field that will enable a wide variety of novel applications that were not possible before. Compared to current underground sensor networks, which use wired communication methods for data retrieval, WUSNs have several remarkable merits, such as concealment, ease of deployment, timeliness of data, reliability and coverage density [2]. The realization of wireless underground communication and networking techniques will lead to potential applications in the fields of agriculture, border patrol, assisted navigation, sports field maintenance, intruder detection, and infrastructure monitoring.

International Journal of Innovative Research in Science, Engineering and Technology

(A High Impact Factor, Monthly, Peer Reviewed Journal)

Visit: www.ijirset.com

Vol. 8, Special Issue 2, March 2019

Many of these novel applications will be possible because WUSNs can provide localized and real-time data about a specific soil region and its surrounding area. Despite In this chapter, we introduce the oretical models to characterize the underground wireless channel. The models developed in this chapter characterize not only the propagation of EM wave in soil, but also other effects on the communication related to multi path effects, soil composition, water content, and burial depth. The results obtained from this formalization reveal that underground communication is severelyaffected by frequency and soil properties, and more specifically by the volumetric water content (VWC) of soil. Moreover, the effects of weather and season changes are investigated by considering two soil types as examples. Such theoretical models are essential for laying out the foundations for efficient communication in this environment.

II. RELATED WORK

WUSN has been investigated in many contexts recently. Research reports on WUSN in agricultural application are few, though the present study include mainly path loss, bit error rate, maximum transmission distance, test error of water content of path transmission of the electromagnetic wave under the main influence factors; these factors are soil types, volumetric water content of the soil, depth of nodes buried, internodes distance, the range of frequency, etc. But this design takes digital sensor DS18B20 to collect soil water content. DS18B20 which is one of the single line digital temperature sensors. It has many advantages such as miniaturization, low power consumption, high performance and strong anti-interference ability and is an easy to match microprocessor.

A. Underground Communication Networks

Wireless Underground Communication Networks (WUCNs) can be mainly classified into two: wireless communication networks for mines and tunnels and wireless underground sensor networks (WUSNs). There exist several solutions that focus on underground communication in mines and/or tunnels. In this context, although the network is located underground, the communication takes place through the air, i.e., through the voids that exist underground. Consequently, even though the communication in these voids are more challenging than that in terrestrial WSNs, the channel characteristics exhibit similarities with the terrestrial WSNs. The soil regions may be distinct in terms of soil texture and water content.

- The topsoil region, which refers to the first 30 cm of soil, or the root growth layer, whichever is shallower.
- The subsoil region, which refers to the region below the topsoil, i.e., usually the 30-100 cm region.

B. Signal passing

WUSN is a specialized kind of WSN that mainly focuses on the use of sensors at the subsurface region of the soil. WUSN transmitter transmit the data using magnetic induction coil. Magnetic induction (MI) is a promising alternative physical layer technique for underground wireless communication. The propagation medium is no longer air but soil, rock and water, where the well established terrestrial wireless communication techniques do not work well. Traditional techniques using electromagnetic (EM) waves encounter three

International Journal of Innovative Research in Science, Engineering and Technology

(A High Impact Factor, Monthly, Peer Reviewed Journal)

Visit: www.ijirset.com

Vol. 8, Special Issue 2, March 2019

major problems in underground environments: high path loss, dynamic channel condition and large antenna size . EM waves experience high levels of attenuation due to absorption by soil, rock, and water in the underground. The path loss is highly dependent on numerous soil properties such as water content, soil makeup (sand, silt, or clay) and density, and can change dramatically with time (e.g., increased soil water content after a rainfall) and space (soil properties change dramatically over short distances).

III. HARDWARE CONFIGURATION TRANSMITTER MODULE

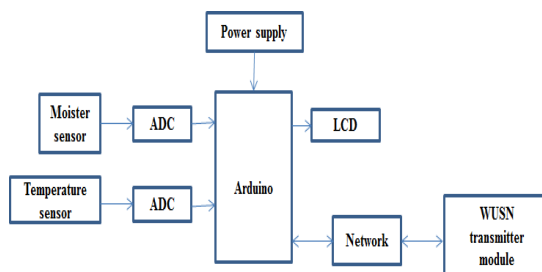

RECEIVER MODULE

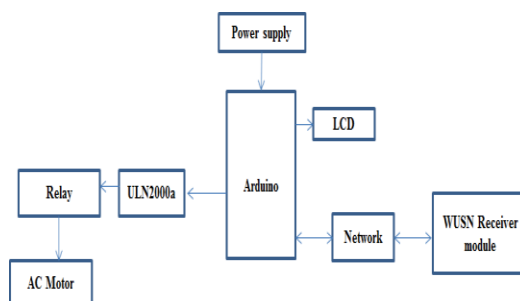

BLOCK DIAGRAM OF PROPOSED SYSTEM AUDUINO UNO

Arduino Uno is a microcontroller board based on the ATmega328P. It has 14 digital input/output pins (of which 6 can be used as PWM outputs), 6 analog inputs, a 16 MHz quartz crystal, a USB connection, a power jack, an ICSP header and a reset button. It contains everything needed to support the microcontroller; simply connect it to a computer with a USB cable or power it with a AC-to-DC adapter or battery to get started.. You can tinker with your UNO without warring too much about doing something wrong, worst case scenario you can replace the chip for a few dollars and start over again.

WIRELESS UNDERGROND SENSOR NETWORK

Wireless Underground Sensor Networks (WUSNs) constitute one of the promising application areas of the recently developed wireless sensor networking techniques. WUSN is a specialized kind of WSN that mainly focuses on the use of sensors at the subsurface region of the soil. For a long time, this region has been used to bury sensors, usually targeting irrigation and environment monitoring applications, although without wireless communication capability. WUSNs promise to fill this gap and to provide the infrastructure for novel applications. The main difference between WUSNs and the terrestrial WSNs is the communication medium. In fact, the differences between the propagation of electromagnetic (EM) waves in soil and in air are so significant that a complete characterization of the underground wireless channel was only available recently

International Journal of Innovative Research in Science, Engineering and Technology

(A High Impact Factor, Monthly, Peer Reviewed Journal)

Visit: www.ijirset.com

Vol. 8, Special Issue 2, March 2019

COMMUNICATION CHANNEL OF WUSN



- Underground-To-Underground Communication (UG2UG)
- Underground-To-Aboveground Communication (UG2AG)
- Aboveground-To-Underground Communication (AG2UG)

IV. LITERATURE SURVEY

Sensor networks are emerging as a great aid to improve agriculture quality, productivity and resource optimization. To evaluate environmental parameters such as humidity, temperature, moisture etc sensor network is used. Now a day's many researchers are working on WSN. Many new technologies in WSN have become available to improve agricultural quality. Precision agriculture is a field which provides one of the most suitable scenarios for the deployment of wireless sensor networks (WSNs). The particular characteristics of agricultural environments

- which may vary significantly with location
- make WSNs a key technology able to provide accurate knowledge to farmers. This knowledge represents a valuable resource because it enables real-time decision making with regard to issues such as establishing water saving policies while providing adequate irrigation and choosing the right time to harvest the fruit based on its maturity. Due to advancement in technologies and reduction in size, sensors are becoming involved in almost every field of life. Agriculture is one of such domains where sensors and their networks are successfully used to get numerous benefits.

V. CONCLUSION

Finally, the feasibility of WUSNs depends on the investigation of multiple novelfactors not considered for traditional terrestrial WSNs. For instance, WUSNs mustbe robust enough to environment parameters, such as VWC and soil composition.To this end, a new generation of sensors with more powerful transceivers may benecessary. However, there are many specific positive features of the underground environment, such as the temporal stability, that can be exploited to achieve reliableand energy-efficient communication. The test result show underground communication is potential technology for WUSN.

International Journal of Innovative Research in Science, Engineering and Technology

(A High Impact Factor, Monthly, Peer Reviewed Journal)

Visit: www.ijirset.com

Vol. 8, Special Issue 2, March 2019

REFERENCES

1. I.F. Akyildiz, W. Su, Y. Sankarasubramaniam, E. Cayirci, Wireless sensor networks: a survey, *Computer Networks Journal* 38 (4) (2002) 393–422.
2. I.F. Akyildiz, E.P. Stuntebeck, Wireless underground sensor networks: research challenges, *Ad Hoc Networks Journal* 4 (2006) 669–686.
3. I.F. Akyildiz, Z. Sun, M.C. Vuran, Signal propagation techniques for wireless underground communication networks, *Physical Communication Journal* 2 (3) (2009) 167–183.
4. Chehri, P. Fortier, P.M. Tardif, Security monitoring using wireless sensor networks, in: *Communication Networks and Services Research, 2007—CNSR'07*, May 2007, pp. 13–17.
5. G.A. Kennedy, P.J. Foster, High resilience networks and microwave propagation in underground mines, in: *The 9th European Conference on Wireless Technology 2006*, September 2006, pp. 193–196.
6. Z. Sun, I.F. Akyildiz, Channel modeling and analysis for wireless networks in underground mines and road tunnels, *IEEE Transactions on Communications* 58 (6) (2010). [7] A.R. Silva, M.C. Vuran, Empirical evaluation of wireless underground-to-underground communication in wireless underground sensor networks, in: *Proc. IEEE DCOSS'09*, Marina Del Rey, CA, June 2009.
7. A.R. Silva, M.C. Vuran, Communication with aboveground devices in wireless underground sensor networks: an empirical study, in: *IEEE ICC'10*, Cape Town, South Africa, May 2010.
8. E. Stuntebeck, D. Pompili, T. Melodia, Underground wireless sensor networks using commodity terrestrial motes, poster presentation at *IEEE SECON 2006*, September 2006.