

International Journal of Innovative Research in Science, Engineering and Technology

(A High Impact Factor, Monthly, Peer Reviewed Journal)

Visit: www.ijirset.com

Vol. 9, Issue 2, February 2020

Design and Analysis of Electromagnetic Braking System

A.Harris¹, J.Joseph Ajith Kumar¹, Jibin Sam Mathew¹, T.Karthikeyan¹, J.Y.Arthur Jebaraj²,
I.Neethi Manickam², S.Shiek Sulaiman²

Final year students, Department of Mechanical Engineering, Francis Xavier Engineering College, Tirunelveli,
Tamil Nadu, India¹.

Professor, Department of Mechanical Engineering, Francis Xavier Engineering College, Tirunelveli,
Tamil Nadu, India²

ABSTRACT: This project is a new technology in braking system. Electromagnetic braking system is used in light motor and heavy motor vehicle like buses, truck, etc. An Electromagnetic Braking system uses Magnetic force to engage the brake, but the power required for braking is transmitted manually. The electromagnetic braking systems are also called electro-mechanical brake. In Future we can use this braking system to avoid the accidents. An electromagnetic braking system uses a magnetic force to apply brake. The power source used in the electromagnetic break is electric current. The electric power applied to the magnetic coil develops the magnetic field in armature coil and attracts the electromagnet aluminum disc. Applying brake to stop the vehicle.

I. INTRODUCTION

A brake is a device which inhibits motion. Its opposite component is a clutch. Most commonly brakes use friction to convert kinetic energy into heat, though other methods of energy conversion may be employed. For example regenerative braking converts much of the energy to electrical energy, which may be stored for later use. The brakes are different to use in stopped the reciprocating parts and motion automobile vehicles. The new technology is produced in automobile engineering. An automobile industry is developing new technology of braking system. These worlds are new possibility and new thinking of braking system. The automobile industry are also developed new braking system like to drum brake, disc brake, hydraulic brake, pneumatic brake, air brake and electromagnetic brake. The different brakes are working on different principle operation. Future is used in time of hydraulic and disc or drum brake. The different types of friction brake and electromagnetic brake use. The main principle of electromagnetic brake to induced kinetic energy into heat energy. Braking system is used to automobile vehicle speed reduced in slowly. The brake are applied the manually force on a brake pedal to the mechanical linkage operate and applied the brake drum wheel and motion is slowly reduced and applied the brake. Brake applied to the vehicle speed reduced in several time and vehicle to rest. The electromagnetic brakes are new technology of automobile industry for future concept to use for automobile vehicle and other industry level. Brakes are new technology to use for vehicle required specification. Automobile vehicle to use for required use in purpose for like sports car, light motor vehicle, heavy motor vehicle, bikes, sports bikes and off road vehicles. Heavy motor vehicle is use brakes this time of air brakes. The electromagnetic brakes are new developed in braking system in automobile engineering. This type brake mainly working principle is one rotating metal disc in between the two magnets to apply the brake to induced electric current in circuit to induced magnetic field in armature to attract the magnet to the rotating metal disc and stopped the rotation in several time while applied brake.

International Journal of Innovative Research in Science, Engineering and Technology

(A High Impact Factor, Monthly, Peer Reviewed Journal)

Visit: www.ijirset.com

Vol. 9, Issue 2, February 2020

II. OBJECTIVE

- To satisfy all the energy requirements of braking without friction.
- To have better heat dissipation capability to avoid problems in friction brakes.
- To used as a supplementary retardation equipment in addition to the regular friction brakes on heavy vehicles.
- To use as an alternative method for the future crisis of the crude oils.

III. WORKING OF ELECTROMAGNETIC BREAK

The electromagnet is energized by the AC supply where the magnetic field is produced to provide the braking mechanism. When the electromagnet is not energized, the rotation of the disc is free and accelerates uniformly under the action of weight to which the shaft is connected. When the electromagnet is energized, magnetic field is produced thereby applying brake by retarding the rotation of the disc and the energy absorbed is appeared as heating of the disc. So when the armature is attracted to the field the stopping torque is transferred into the field housing and into the machine frame decelerating the load. The AC motor makes the disc to rotate through the shaft by means of pulleys connected to the shaft.

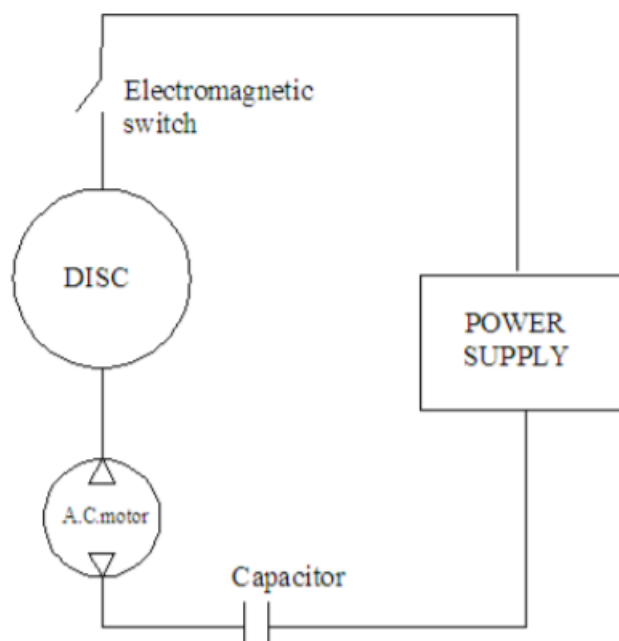

Fig: A. Electromagnetic breaking system

IV. WORKING

The eddy current brake has its origin in France by a Frenchmen named as Jean Bernard Foucault in 19th century. HE observed that greater force is needed to rotate the copper disc in between two poles of magnet or magnetic poles, and at the same time the copper disc warmed up. The working principle of the electromagnetic brakes is based on the creation of the eddy currents within a metal disc rotating between two electromagnets, which set up the force opposing the rotation of disc. Generally, when the brakes are not applied then the circuit is incomplete and the electromagnet is not energized. When in normal case the disc mounted on the shaft rotates without any retardation.

International Journal of Innovative Research in Science, Engineering and Technology

(A High Impact Factor, Monthly, Peer Reviewed Journal)

Visit: www.ijirset.com

Vol. 9, Issue 2, February 2020

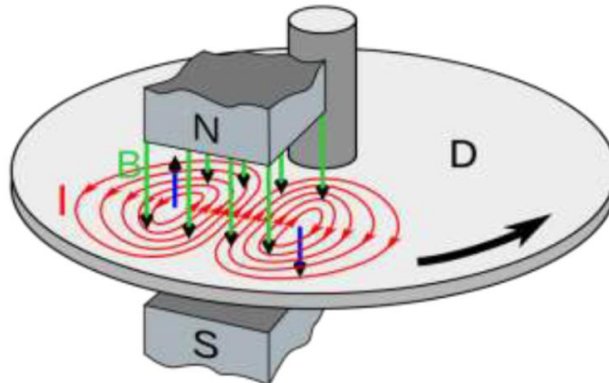

Fig: 1, Induction of magnetic field

In case of application of brakes the circuit is completed then the electromagnet is energized then eddy currents are generated in the rotating disc, the direction of force exerted by eddy currents is exactly opposite to the direction of rotation, hence causing the brakes to stop. This is the simple working of electromagnetic brakes where the amount of current applied is not measured. In practical application, rheostat is used to determine the energy requirement paired with RPM sensors. The braking force is indirectly proportional to the value of current. The development of Electromagnetic brakes was started by a French company associated with Raoul Sarazin developed and marketed several generations of electromagnetic brakes. A typical retarder consists of stator and rotor. The stator holds induction coils made up of aluminum wires. This is mounted on the frames on this makes the non rotating member or stator. The rotor consists of the two disc brakes which generate the braking action when electromagnets in stators are energized. Heat dissipation arrangement is given for cooling. All the disc can function individually and the system can be controlled by micro controller. Hence if brakes on a single wheel fail then the system can sense the failure of braking assembly and Force on other three wheels can be redistributed. Microcontroller can equally distribute the braking force hence avoiding loss of control in such an event. In case of conventional braking system failure of brake on single wheel can cause imbalanced force which may cause loss of control and driver and vehicle may be pushed into harm's way instead of safety

V. MATERIALS USED

- 1) Shaft (MS Steel)
- 2) AC motor
- 3) Disc (Aluminium)
- 4) Electromagnet
- 5) Ball Bearing (SS)
- 6) L – bar (MS)
- 7) Controller
- 8) Transformer
- 9) Switch

International Journal of Innovative Research in Science, Engineering and Technology

(A High Impact Factor, Monthly, Peer Reviewed Journal)

Visit: www.ijirset.com

Vol. 9, Issue 2, February 2020

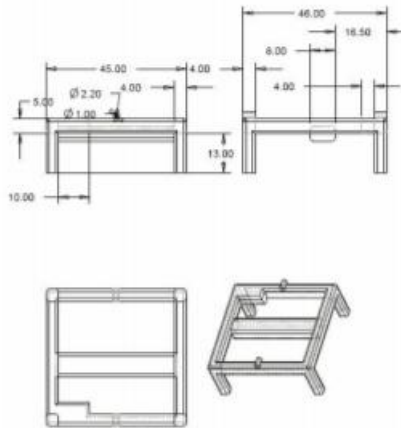

Fig: 1.1, Diagrammatic Representation of Experimental setup

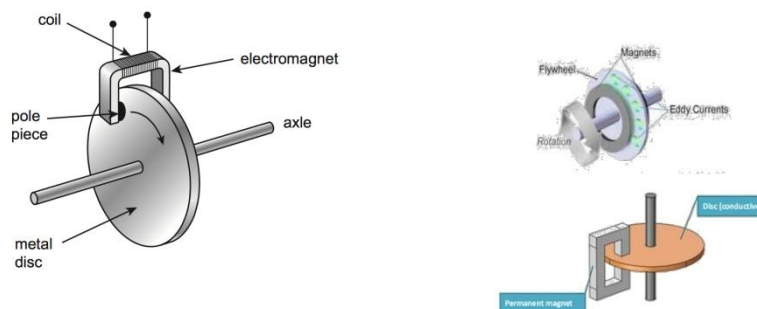

Fig: 1.2, Electromagnet parts and arrangements

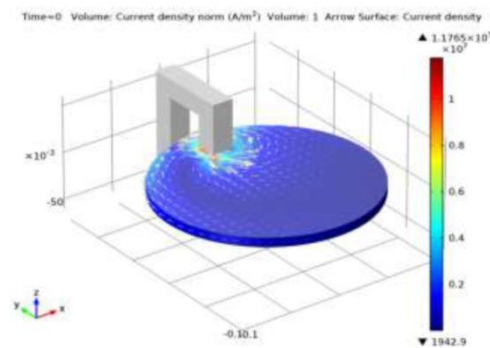

Fig: 1.3, Stress Distribution on Disc

Advantage:

- Maintenance cost is very less.
- Changing of parts due to wear and tear is less.
- Easier integration with anti-lock, traction system.
- Individual wheel braking is possible.

International Journal of Innovative Research in Science, Engineering and Technology

(A High Impact Factor, Monthly, Peer Reviewed Journal)

Visit: www.ijirset.com

Vol. 9, Issue 2, February 2020

- A problem of wear and tear is negligible.
- No need for special changes in hot or cold climates like in case of disc brakes.
- There is no oil leakage.

Applications

- 1) Used In Railway
- 2) Used in automobiles(super cars)
- 3) Used in roller coaster in theme park
- 4) Used in Industrial lift
- 5) Used in air craft

VI. CONCLUSION

With all the advantages of electromagnetic brakes over friction brakes, they have been widely used on heavy vehicles where the 'brake fading' problem exists. The same concept is being developed for application on lighter vehicles. These electromagnetic brakes can be used as an auxiliary braking system along with the friction braking system to avoid overheating and brake failure. ABS usage can be neglected by simply using a micro controlled electromagnetic disk brake system. These electromagnetic brakes can be used in wet conditions which eliminate the anti-skidding equipment. Hence the braking force produced in this is less than the disc brakes if can be used as a secondary or emergency braking system in the automobiles.

ACKNOWLEDGEMENT

I am thankful to and fortunate enough to get constant encouragement, support and guidance from teaching staffs which helped us in successfully completing our project work. Also, I would like to extend our sincere esteems to all staff in laboratory for their timely support.

REFERENCES

- 1) Sumit Patel, "Development of the Electro-Magnetic Brake", IJIRST –International Journal for Innovative Research in Science & Technology| Volume 1 | Issue 12 | May 2015
- 2) Sevel P, Nirmal Kannan V, Mars Mukesh S, "Innovative Electro Magnetic Braking System", IJIRSET, April 2014
- 3) Oriano Bottauscio, Mario Chiampi, Alessandra Manzin, "Modeling analysis of the electromagnetic braking action on rotating solid cylinders", Science Direct, December 2006
- 4) [AkshayKumar S. Puttevar, Nagnath U. Kakde, Huzaiifa A. Fidvi, Bhushan Nandeshwar, "Enhancement of braking system in automobile using Electromagnetic Braking", IOSR-JMCE
- 5) McConnell, H.M, "Eddy current phenomena in ferromagnetic material", AIEE Transaction, vol.73, part-I, pp 226-234, July 2016.
- 6) Flemming, Frank; Shapiro, Jessica (July 7, 2009). "Basics of Electromagnetic Brakes" .machine design: pp. 57–58 .
- 7) Sumit Dhangar, Ajinkya Korane, and Durgesh Barve, "Magnetic Piston Operated System," International Journal Of Advance Research In Science And Engineering, Vol.4, pp.219-225, June 2015.
- 8) M.S.Kumbhar, Prof. Dr.D.R Panchagade, "A Literature Review On Automated Manual Transmission (ATM)," International Journal For Scientific Research And Development, Vol.2, pp.1236-1239, 2014.
- 9) Abhishek Gaikwad, Deepak Singh, Mohammad Adnaan Nizami, Siddhartha Tripathi, and Zubair Abrar Khan, "Fabrication Of Prototype Model Of Infrared Sensor Based Regenerative Braking System Using Electromagnetic Clutch," International Journal Of Modern Engineering Research, Vol.4, pp.31-36, May 2014.
- 10) Abil Joseph Eapen, Aby Eshow Varughese, Arun T.P, and Athul T.N, "Electromagnetic Engine," Internatinal Journal Of Research In Engineering And Tecnology Vol.3, pp.31-35, June 2014.
- 11) Jiang Kejun, He Ren, and Zhang Lauchun, "Application And Control Method Of Electromagnetic Synchronizer For Double Rotor Motor Power Coupling System," Electronics, Vol.19, No.2, pp.88-93, December 2015.
- 12) Stephen Z Oldakowski, "Latching Brake Using Permanent Magnet," Bedford, Ohio United States Patent Patent Number 5,121,018.