

International Journal of Innovative Research in Science, Engineering and Technology

(A High Impact Factor, Monthly, Peer Reviewed Journal)

Visit: www.ijirset.com

Vol. 9, Issue 3, March 2020

Footstep Electricity Generator

Akshay Ambekar¹, Rushant Bendre², Nikhil Shinde³, Rohan Hivrale⁴, Pritam Durge⁵, Prof. Sonali Gaikwad.⁶

Student, Department of Computer, JSPM BSP, Wagholi, India ^{1,2,3,4,5}

Faculty, Department of Computer, JSPM BSP, Wagholi, India ⁶

ABSTRACT: In this foot step power generation project is designed to convert foot step, walking and running energy into electrical energy. It is used to generate electricity from by walking or running on foot step. The demand of electrical energy is increasing day by day. But power generation conventional resources are now not enough for total demand of electrical energy. Therefore many researchers and engineers are working on non-conventional ways of electrical power generation. Foot step power generation system is also a non-conventional electrical energy production system. It converts mechanical energy of footsteps into electrical energy by using transducers. This power generation system can become very popular among populated countries like Pakistan, china, India. It can be implemented on roads, bus stations and many public places. Although this system is little bit expensive, but it can make a huge difference in electrical power generation of country. Foot step power generation system basically converts force energy of foot into electrical energy by using piezoelectric sensor. Piezoelectric sensor is transducer which converts force energy into electrical energy.

KEYWORDS: Energy Crisis, Supply and demand, Renewable Energy, Piezoelectric, Electrical Energy, Footstep power generation system.

I. INTRODUCTION

Walking is the most common activity in day to day life. When a person walks, he loses energy to the road surface in the form of impact, vibration, sound etc, due to the transfer of his weight on to the road surface, through foot falls on the ground during every step. This energy can be tapped and converted in the usable form such as in electrical form.

In order to develop a technique to harness foot step energy, a foot step electricity generating device was developed in the Reactor Control Division, BARC. This device, if embedded in the footpath, can convert foot impact energy into electrical form. The working principle is simple. When a pedestrian steps on the top plate of the device, the plate will dip down slightly due to the weight of the pedestrian. The downward movement of the plate results in rotation of the shaft of an electrical alternator, fitted in the device, to produce electrical energy. The top plate reverts back to its original position due to negating springs provided in the device.

If such devices are embedded in places where there is continuous human traffic such as in city malls, railway platforms, city footpaths etc., the electricity generated from these devices can be used for street lights.

International Journal of Innovative Research in Science, Engineering and Technology

(A High Impact Factor, Monthly, Peer Reviewed Journal)

Visit: www.ijirset.com

Vol. 9, Issue 3, March 2020

II. LITERATURE SURVEY

1. SanketBorkar, AnkitTripathi, AmitChandrikapure, ``Design and Fabrication of Foot Step Power Generator'' IJIRT Volume 4 Issue 10 March 2018

In this project electrical power is generated using non-conventional method by simply running on the foot step. eg. Railway stations. Non-conventional energy system is very essential at this time to our nation. Non-conventional energy using foot step needs no fuel input power to generate the output of electrical power. This project is made using simple drive mechanism such as rack and pinion assembly. For this project the conversion of the forced mechanical energy into electrical energy. The control mechanism carries the rack and pinion, D.C generator, battery. This project is implemented to all foot step. The generated power is stored by means of battery and this is used for activating the connected loads. This is one of the compact and efficiency systems for generating electricity which can be easily installed in many region.

2. SHUBHAM KUMAR, SHARAD MITTAL, SACHIN SAINI, VISHNU PAL, ``FOOT STEP ENERGY CONVERSION SYSTEM'' Volume 7, Issue 5, May-2016

In this project we are produced electrical energy by pedestrian and moving vehicles on the ground surface by means of renewable energy generation method. As our country is a developing country so the renewable energy resource are very important at this time. The renewable energy using foot step impact load of human and vehicles is converted into electrical energy. The main motto of this mechanism is to create cheaper and better way of electrical power generation method; this system does not create any kind of pollutants so that we can decrease the most powerful effect greenhouse effect and power shortage so that we will get rid of the problem of power cuts. In this project the interchange of impact load due to the heavy weight into electrical energy by using simple rack-pinion gear drive mechanism because of its specification, linear motion can be converted into rotatory motion. In this project impact load is converted into electrical energy. The whole mechanism includes rack-pinion, gear mechanism, a shaft and dynamo. We can store produced electrical energy by the implementation of the combination of inverter and a battery.

3. Sarat Kumar Sahoo ``FOOT STEP POWER GENERATION'' Volume 7, Issue 2, March-April 2016, pp. 187-190

Since in this project of power generation there is not any fuel input requirement for the generation of electrical power. Thus it can also be concluded that this mode of power generation system is eco-friendly, i.e., no pollution is caused during the generation of power using this type of model. Hence due to such advantages, this system can be embedded at any of the public places like railway platforms, busy footpaths, malls etc. Implementing this system, we can easily reduce our dependency on the conventional sources of energy, thus can be considered beneficial from that point of view.

4. Shiraz Afzal, Farrukhhafeez, ``Power Generation Footstep'' Volume 3, Issue 4, April-2014

This paper is all about generating electricity when people walk on the Floor. Think about the forces you exert which is wasted when a person walks. The idea is to convert the weight energy to electrical energy The Power Generating floor intends to translate the kinetic energy to the electrical power. Energy Crisis is the main issue of world these days. The motto of this research work is to face this crisis somehow. Though it won't meet the requirement of electricity but as a matter of fact if we are able to design a power generating floor that can produce 100W on just 12

International Journal of Innovative Research in Science, Engineering and Technology

(A High Impact Factor, Monthly, Peer Reviewed Journal)

Visit: www.ijirset.com

Vol. 9, Issue 3, March 2020

steps, then for 120 steps we can produce 1000 Watt and if we install such type of 100 floors with this system then it can produce 1MegaWatt. Which itself is an achievement to make it significant.

- Tom Jose V, BinoyBoban, Sijo M T, "Electricity Generation from Footsteps; A Regenerative Energy Resource" Volume 3, Issue 3, March 2013

A slab of concrete harnesses kinetic energy whenever it is stepped on. This energy, created by 5 millimeters of flex in the material, is then either stored by lithium polymer batteries contained within the slabs or transmitted immediately to streetlights or other electronics located close by. The current model, made from stainless steel, recycled car tires and recycled aluminum, also includes a lamp embedded in the pavement that lights up every time a step is converted into energy (using only 5 percent of the generated energy).

III. SYSTEM ARCHITECTURE

Working of footstep power generation system consists of following main points:

- Piezoelectric sensor interfaced with microcontroller and used as a transducer to convert force energy into electrical energy
- It consists of large number of Piezoelectric sensors connected in series. Kinetic energy of series connected transducers is converted into electrical energy.
- Voltages generated by piezoelectric sensors are feed to circuit elements to get proper output.
- Output energy is stored in batteries.

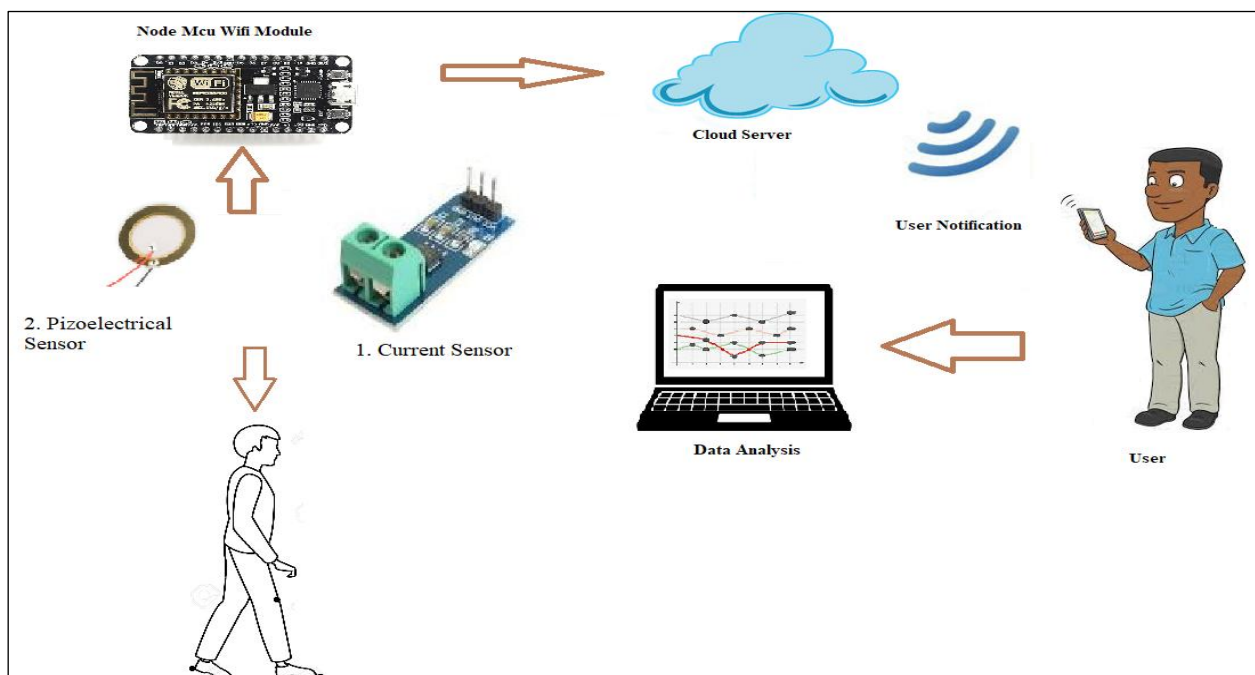

Fig.1 : Block Diagram

International Journal of Innovative Research in Science, Engineering and Technology

(A High Impact Factor, Monthly, Peer Reviewed Journal)

Visit: www.ijirset.com

Vol. 9, Issue 3, March 2020

Hardware and Software Specification

Hardware Specification

- Node MCU
- Piezoelectric Sensor
- Current Sensor(ACS 712)

Software Specification

- Arduino IDE 1.8.11

ADVANTAGES

- To store the electricity in battery.
- It can be use at any time when it necessary.
- Easy construction.
- Less number of parts required.
- Electricity can used for many purposes

IV. APPLICATIONS

Foot step power generation systems have many applications, but some of them are given below:

- Mobile charging
- street lighting
- bus station lighting
- Emergency power failure stations
- Rural areas etc.

V. CONCLUSION

The system generates voltage using footstep force. The system serves as a medium to generate electricity using non-conventional sources (force) and /store/use it. The project is designed to be useful at public places like railway stations where a lot of people keep walking through all day. At such places these systems are to be placed at any entry points where people travel through entrance or exits and they have to step on this device to get through. These devices may then generate a voltage on every footstep and when mounted in series they will produce a sizeable amount of electricity. For this purpose we here use piezoelectric sensors that use piezoelectric effect in order to measure acceleration, force, pressure by its conversion into electric signals.

REFERENCES

1. SanketBorkar, AnkitTripathi, AmitChandrikapure, "Design and Fabrication of Foot Step Power Generator" IJIRT Volume 4 Issue 10 March 2018
2. SHUBHAM KUMAR, SHARAD MITTAL, SACHIN SAINI, VISHNU PAL, "FOOT STEP ENERGY CONVERSION SYSTEM" Volume 7, Issue 5, May-2016



ISSN(Online): 2319-8753
ISSN (Print): 2347-6710

International Journal of Innovative Research in Science, Engineering and Technology

(A High Impact Factor, Monthly, Peer Reviewed Journal)

Visit: www.ijirset.com

Vol. 9, Issue 3, March 2020

3. Sarat Kumar Sahoo ``FOOT STEP POWER GENERATION'' Volume 7, Issue 2, March-April 2016, pp. 187–190
4. Shiraz Afzal, Farrukhhafeez, ``Power Generation Footstep'' Volume 3, Issue 4, April-2014
5. Tom Jose V, BinoyBoban, Sijo M T, ``Electricity Generation from Footsteps; A Regenerative Energy Resource'' Volume 3, Issue 3, March 2013
6. Muhammad Shahid, Tufail, Hamid, Mehovic, ``Investigation of the ways to improve the performance of a plant'' vol. 1, pp. 1-6, June 2007
7. N.C. Nigam, A. K. Maheshwari, N.P. Rao ;Brief presentation of various facets of Safety and Health in chemical Industries with a special focus at Indian Farmers Fertiliser Cooperative Ltd.,(IFFCO)–Aonla unit; vol. 1, pp. 4-9, 2006.
8. J. Leslie Goodier, E. Boudreau, G. Coletta. R. Lucas, ``Industria Health and Safety Criteria for Abrasive Blast Cleaning Operations''. vol. 1, pp. 5-7, June 1996.
9. Dekker S.W.A, ``Reconstructing human contributions to accidents,`` The new view on error and performance, Journal of Safety Research, 33, 371-385. 2002,
10. Bell J., Holroyd J., 2009, ``Review of human reliability assessment methods'', Health and Safety Executive books, May 2012.