



e-ISSN: 2319-8753 | p-ISSN: 2347-6710

IJRSET

International Journal of Innovative Research in
SCIENCE | ENGINEERING | TECHNOLOGY

INTERNATIONAL JOURNAL OF INNOVATIVE RESEARCH

IN SCIENCE | ENGINEERING | TECHNOLOGY

Volume 10, Special Issue 3, December 2021

ISSN INTERNATIONAL
STANDARD
SERIAL
NUMBER
INDIA

Impact Factor: 7.569

9940 572 462

6381 907 438

ijirset@gmail.com

www.ijirset.com

Deep Learning Based LSSK

Safna Ashraf T¹, Najiya Abdulrahiman²

Student, Department of Electronics and Communication Engineering, Royal College of Engineering, Akkikavu, Kerala, India¹

Assistant Professor, Department of Electronics and Communication Engineering, Royal College of Engineering, Akkikavu, Kerala, India²

ABSTRACT: In this paper we consider Layered Space Shift Keying (LSSK) modulation with detection based on deep learning. LSSK can fully exploit the spatial domain and thus improves the spectrum efficiency than space shift keying (SSK) modulation. Transmitted symbol is estimated from the received signal using Neural Network (NN) detector instead of Layered and Joint (LJ) detector. This is achieved in two phase, first the neural network is trained using a training data set. Once it is trained offline the detector estimate the data in real time as the signal stream arrives at the receiver. Proposed detection is computationally efficient. Result demonstrates that the BER performance of the proposed NN detector is better than the layered and joint (LJ) detector in LSSK.

KEYWORDS: Layered Space Shift Keying, Neural network, Bit error rate.

I. INTRODUCTION

The increasing requirements of high data rate and high spectrum efficiency have led to extensive research on multiple-input multiple-output (MIMO) techniques. In conventional MIMO transmission techniques all data bits are conveyed by transmitting amplitude and phase modulation (APM) symbols. While SSK conveys information by means of active antenna indices rather than amplitude and phase modulation symbols and also has only one active antenna at a time. Since SSK activates only one antenna each time, it provides benefits such as no inter channel interference, no inter-antenna synchronization and reduction of radio frequency (RF) chains compared with conventional MIMO systems. In order to increase the spectrum efficiency of SSK, fully exploit the spatial domain.

Detection in LSSK was first done using optimal maximum likelihood (ML) detection where the objective is to search over all possibilities to find the best transmission mode to maximize the maximum likelihood probability. Aim of ML detections to find the best transmit mode that minimize the BER performance. Later a low complexity near optimal layered and joint detector was introduced which find the activated antenna index/position instead of finding the transmit mode. Thus it significantly reduced detection complexity, and obtains compromise between complexity and performance.

Paper is organized as follows. Section II describes LSSK modulation and demodulation and block diagram of the system. Detection using neural network is explained in Section III. Section IV presents experimental results showing BER performance of NN detector versus previously used LJ detector. Finally, Section V presents conclusion.

II. LSSK

The concept of LSSK introduced in [1] explains the modulation and demodulation clearly. In LSSK modulation LSSK first sent the source bits in to layer mapping where the information bits are first divided into different blocks and each blocks is divided into L layers. Each layer consist of $\log_2 M$ bits where M is order of SSK. Bit mapping is done next where M-array SSK is done in each layer. A sparse transmit signal is generated and emitted after LSSK modulation which consist of L layers signals. The signals are the predetermined rotated symbols to identify the i -th layer.

LSSK demodulation is the reverse operation of the modulator, where the modulator utilizes the antenna cancellation method to form the layered transmission. LSSK demodulation consists of a bit-de-mapping and a layer de-mapping block, which perform the corresponding reverse bit-mapping and layer mapping operations at the transmitter respectively. The detection results from NN detection are sent into the bit-de-mapping block first and then the layer de-mapping block to recover the successive source binary bits.

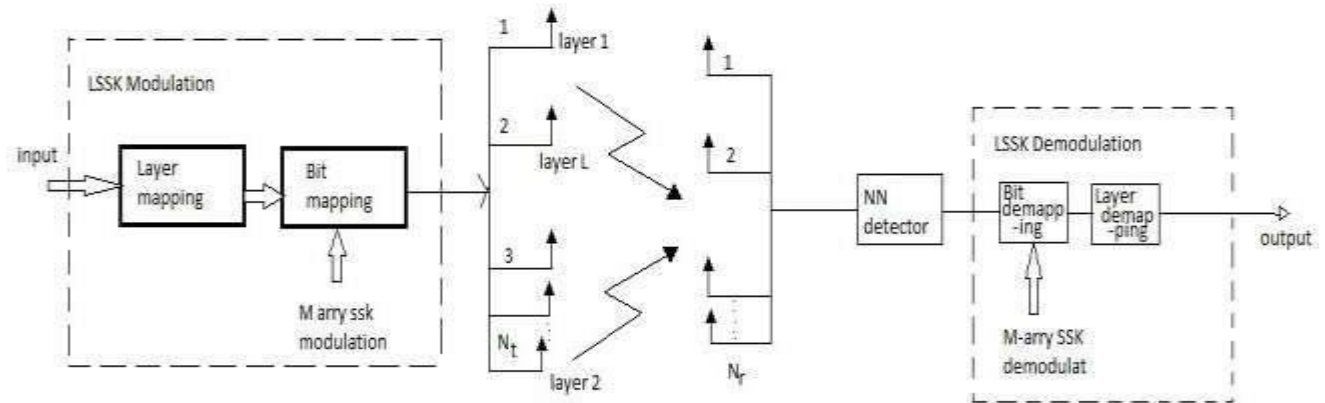

Fig 2.1 System Block Diagram

An LSSK system is considered with N_t transmit and N_r receive antennas respectively, as depicted in fig 2.1. The information bits are first sent to LSSK modulation block to generate the layered transmit signal. A sparse transmit signal S is emitted from the transmitter after LSSK modulation which consist of L layers signal as

$$S = [0 \dots x_1 \dots x_L \dots x_1 \dots 0] \quad (2.1)$$

Where S is the $N_t \times 1$ dimensional sparse transmit signal. S contain L non-zero elements x_i , $i \in L = \{1, 2, \dots, L\}$. The signals x_i are the predetermined rotated symbols to identify the i -th layer. Activated transmit antenna index/ position for the i -th layer is denoted by $a_i \in A = \{1, 2, \dots, N_t\}$. Each active antenna emits one layer's signal which is a predetermined rotated symbol, conveying the same number of $\log_2 M$ bits, where M is the SSK modulation order. Number of transmit antenna N_t is $L + M - 1$.

$$\text{Spectrum efficiency} = L \log_2 M \text{ bps/Hz} \quad (2.2)$$

The received signal at the receiver is given by

$$Y = (\rho/L)^{1/2} Hs + n \quad (2.3)$$

Where ρ is the total transmit power, n is the additive white Gaussian noise (AWGN) and H is the channel matrix.

At the receiver, equalization of received signal is done before detection using a Neural Network (NN) detector, which will be elaborated in Section III. Once the activated antenna index/ position, $\hat{a}_i \in L$ for each layer is obtained after detection, the information bits can be directly recovered by the LSSK demodulation block at the receiver.

III. NN DETECTOR

Transmitted symbol is estimated from the received signals by using Neural Network architectures through supervised learning. This is attained in two steps. First, a training dataset is generated to train the Neural Network offline. Once the network is trained, it can be arranged and used for detection. Once the training phase is implemented offline it is not part of the detection process after arrangement. The detection algorithm goes through two phases. In the first phase, known sequences of symbols from S are transmitted repeatedly and received by the system to create a set of training data. The training data can be generated by selecting the transmitted symbols randomly according to a PMF, and generating the corresponding received signal using mathematical models, simulations, experimental measurements, or field measurements

Organized by

Royal College of Engineering and Technology, Thrissur, Kerala, India

Let $X_k = [x_1, x_2, \dots, x_k]$ be the sequence of k consecutively transmitted symbol and $Y_k = [y_1, y_2, \dots, y_k]$ be the corresponding observed signal sequence. Then the training dataset generated as

$$\{(X_k^{(1)}, Y_k^{(1)}), (X_k^{(2)}, Y_k^{(2)}), \dots, (X_k^{(n)}, Y_k^{(n)})\} \tag{3.1}$$

Deep Neural Network is trained using the training dataset generated and map the received signal y_k to one of the transmission symbols in S. The input to the Neural Network can be the raw detected signal y_k or a set of features r_k take out from the received signals. The neural network output is interpreted as probability vector \hat{X}_k . $\hat{X}_k = N(Y_k; G)$, where G represent the parameters of neural network.

At the time of training, optimal set of parameters G^* for the neural network is found by transmitting a known sequence of symbols.

$$\mathcal{W}^* = \text{arg}_{\mathcal{W}} \min \mathcal{L}(X_k, \hat{X}_k) \tag{3.2}$$

Where f is the loss function. Cross entropy loss function can be used when the neural network output is a PMF. Then

$$\mathcal{L}_{cross} = H(X_k, \hat{X}_k) \tag{3.3}$$

Recurrent neural network (RNN) is used for performing sequence detection. Long short-term memory is used in this work. Thus estimated \hat{X}_k is given by

$$\hat{X}_k = \begin{bmatrix} P_{RNN}(m_k = s_1 | Y_k, Y_{k-1}, \dots, Y_1) \\ P_{RNN}(m_k = s_2 | Y_k, Y_{k-1}, \dots, Y_1) \\ \vdots \\ P_{RNN}(m_k = s_n | Y_k, Y_{k-1}, \dots, Y_1) \end{bmatrix} \tag{3.4}$$

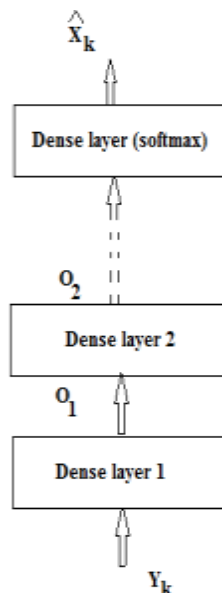

Fig 3.1 NN detector

Basic NN architecture that is used for detection uses several fully connected NN layers followed by a final softmax layer. First layer is image input layer where the input data is fed. Observed signal y or the feature vector r_k is the input to the first layer, which is selectively take out from the observed signal through preprocessing. Next layer is the rectified linear unit layer that makes any negative values to zero. Next layer is dropout layer which eliminates certain data which could not estimate to correct result. Combination of these three layers is repeated. The output of the final layer is of length m and the activation function for the final layer is the softmax activation. This ensures that the output of the layer is a PMF.

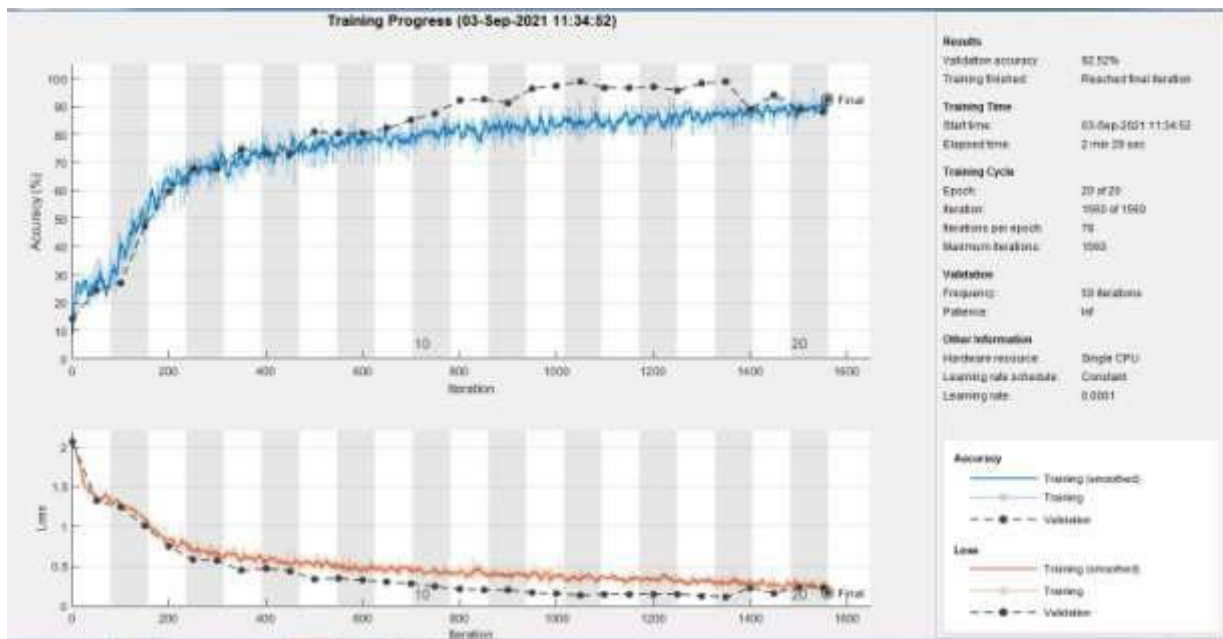

Fig 3.2 NN training progress

IV. EXPERIMENTAL RESULTS

Neural network detector considered in this work are trained using a diverse dataset that contains sequences transmitted under different channel conditions, the detectors will be robust to changing channel conditions, eliminating the need for instantaneous CSI. The training data can be generated by selecting the transmitted symbols randomly according to a PMF, and generating the corresponding received signal using mathematical models, simulations, experimental measurements, or field measurements. BER performance of LSSK using deep learning technique is compared with LSSK using LJ detection, both with the same antenna configurations. It is observed that LSSK outperform LSSK with NN detector in terms of BER performance.

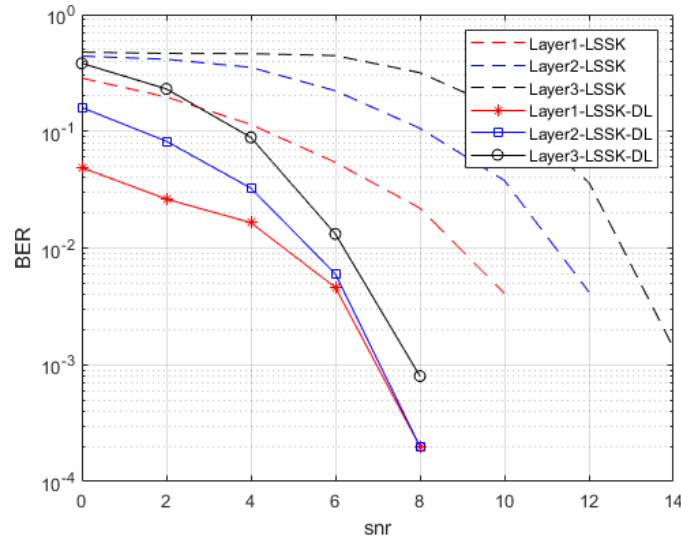

Fig 4.1 BER performance of NN detector versus LJ detector

V. CONCLUSION

We introduce NN detector instead of LJ detector. While analysing the bit error rate it is clear that the BER performance of LSSK with NN detector is much better than the LSSK with LJ detector. Thus deep learning based LSSK improves the BER performance.

REFERENCES

1. Shu Fang, Lei Li, Su Hu, Jianhua Tang, Zongdi Yue, Gang Feng, Ashish Pandharipande, "Layered space shift keying modulation over MIMO", IEEE Transaction, 2016
2. Nariman Farsad and Andrea Goldsmith, "Neural Network Detection of Data Sequences in Communication Systems", IEEE Transaction on signal processing, 2018.
3. Raed Y. Mesleh, Harald Haas, Sinan Sinanovic, Chang Wook Ahn, and Sangboh Yun "Spatial Modulation", IEEE Transactions on Vehicular Technology, 2008.
4. Jeyadeepan Jeganathan, Ali Ghrayeb, Leszek Szczecinski, and Andres Ceron "Space Shift Keying Modulation for MIMO Channels", IEEE Transaction on wireless communication, 2009.
5. Jeyadeepan Jeganathan, Ali Ghrayeb and Leszek Szczecinski "Generalized Space Shift Keying Modulation for MIMO Channels", IEEE Transaction, 2008.
6. Han-Wen Liang, Ronald Y. Chang, Wei-Ho Chung, Hongke Zhang, and Sy-Yen Kuo "Bi-Space Shift Keying Modulation for MIMO Systems", IEEE Transaction, 2012.
7. R. Mesleh, S. S. Ikki, and H. M. Aggoune, "Quadrature Spatial Modulation", IEEE Transaction on vehicular technology, 2014.
8. S. Sugiura, S. Chen, O. Edfors, and L. Hanzo "Generalized space-time shift keying designed for flexible diversity-, multiplexing and complexity tradeoffs", IEEE Transaction on Wireless Communication, 2011.
9. R. Y. Chang, S. J. Lin, and W. H. Chung, "New space shift keying modulation with Hamming code-aided constellation design", IEEE Wireless Communication Letter, 2012.
10. R. Y. Chang, S. J. Lin, and W. H. Chung, "Energy efficient transmission over space shift keying modulation MIMO channels", IEEE Transaction on Wireless Communication, 2012.



Impact Factor:
7.569



INTERNATIONAL JOURNAL OF INNOVATIVE RESEARCH

IN SCIENCE | ENGINEERING | TECHNOLOGY

 9940 572 462  6381 907 438  ijirset@gmail.com



www.ijirset.com

Scan to save the contact details