



e-ISSN: 2319-8753 | p-ISSN: 2347-6710

IJRSET

International Journal of Innovative Research in
SCIENCE | ENGINEERING | TECHNOLOGY

INTERNATIONAL JOURNAL OF INNOVATIVE RESEARCH

IN SCIENCE | ENGINEERING | TECHNOLOGY

Volume 11, Issue 12, December 2022

ISSN INTERNATIONAL
STANDARD
SERIAL
NUMBER
INDIA

Impact Factor: 8.118

 9940 572 462

 6381 907 438

 ijirset@gmail.com

 www.ijirset.com

Power Quality Improvement Using Unified Power Quality Conditioner (UPQC)

Rubi Paliya, Anuradha Pathak

Department of Electrical Engineering, NITM, Gwalior, Madhya Pradesh, India

ABSTRACT: This paper presents a comprehensive review on the unified power quality conditioner (UPQC) to enhance the electric power quality at distribution levels. Unified power quality conditioners (UPQCs) allow the mitigation of voltage and current disturbances that could affect sensitive electrical loads while compensating the load reactive power. The shunt and series active filter performs the simultaneous elimination of current and voltage problems. The power fed is linked through common DC link and maintains constant real power exchange. The DC link is connected through the reactor. The real power supply is given by the photovoltaic system for the compensation of power quality problems. The reference current and voltage generation for shunt and series converter is based on phase locked loop and synchronous reference frame theory.

KEYWORDS: Active power filter (APF), harmonic compensation, power quality, reactive power compensation, unified power quality conditioner (UPQC), voltage sag and swell compensation.

I. INTRODUCTION

Unified power quality conditioners (UPQCs) consist of combined series and shunt active power filters (APFs) for simultaneous compensation of voltage and current disturbances and reactive power. They are applicable to power distribution systems, being connected at the point of common coupling (PCC) of loads that generate harmonic currents. In general, poor power quality may result into increased power losses, abnormal and undesirable behavior of equipment, interference with nearby communication lines, and so forth. The widespread use of power electronic based systems has further put the burden on power system by generating harmonics in voltages and currents along with increased reactive current. The term active power filter (APF) is a widely used terminology in the area of electric power quality improvement. The series APF must compensate the source voltage disturbances, such as harmonics, dips or over-voltages, which might deteriorate the operation of the local load while the shunt APF attenuates the undesirable load current components (harmonic currents and the fundamental frequency component which contributes to the reactive load power). Moreover, the shunt APF must control the dc-bus voltage in order to ensure the compensation capability of the UPQC. These functionalities can be carried out by applying diverse control strategies which can operate in the time domain, in the frequency domain or both. Time domain methods, such as pq or dq based methods allow the fast compensation of time-variant disturbances but make more complex their selective compensation. In this sense, frequency domain methods are more flexible but their dynamical response is slower.

II. POWER QUALITY

Power Quality (PQ) related issues are of most concern nowadays. The widespread use of electronic equipment, such as information technology equipment, power electronics such as adjustable speed drives (ASD), programmable logic controllers (PLC), energy-efficient lighting, led to a complete change of electric loads nature. These loads are

IV. SYNCHRONOUS REFERENCE FRAME (SRF) THEORY

The control strategy for the unified power quality conditioner is based on the synchronous reference frame (SRF) theory. In this theory controlling of the three-phase converters using the rotating frame theory by converting the source voltage and current to direct and quadrature axis is done. The voltage is converted to dq in the series controller and current is converted to dq in the series controller. Consider the shunt converter performs the process of elimination of harmonics and series converter performs process of elimination of the voltage related problems. The control block diagram for the synchronous reference frame theory is shown in Figure 2

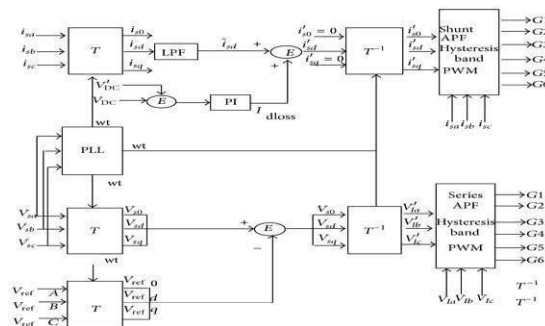

Figure-2: Control Block Diagram

V. SIMULATION RESULTS

The UPQC-CSC has the reactor as the DC link for the series and shunt converter and is controlled by the synchronous reference frame (SRF) theory and the pulse is generated by the hysteresis band controller. The shunt and series converters have the function of compensating current and voltage problems, respectively. The simulation of UPQC-CSC is shown in Figure 3. The output of UPQC-CSC is shown in Figure 4 which shows the voltage with sag, current with harmonics, and compensated voltage and current.

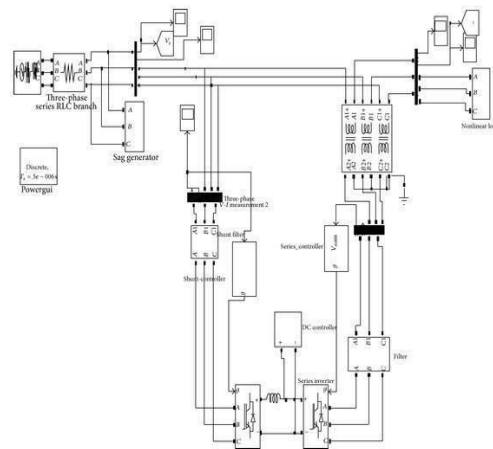

Figure-3: UPQC-CSC simulation diagram

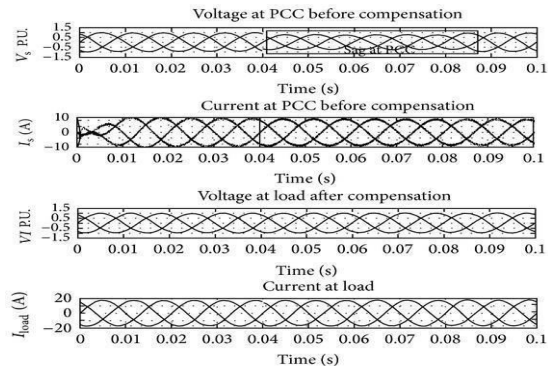

Figure-4: Output of source voltage and current and load voltage and current waveform

VI. CONCLUSION

In this paper, synchronous reference frame theory based control method is implemented to control the working of unified power quality conditioner based on current source converter topology. The simulation results show that the device is capable of compensating the current harmonics under unbalanced and nonlinear load conditions, simultaneously mitigating voltage sag and swell. The proposed UPQC-CSC design has superior performance for mitigating the power quality problems.

APPLICATIONS: Used in

1. Distribution systems,
 2. Transmission systems.
- ADVANTAGES: It compensate
1. Supply voltage
 2. Flicker/imbalance,
 3. Reactive power,
 4. Negative sequence current, And Harmonics.

REFERENCES

1. Khadkikar V. Enhancing electric power quality using UPQC: a comprehensive overview. IEEE Transactions on Power Electronics. 2017; 27(5):2284–2297.
2. Kesler M, Ozdemir E. Synchronous-reference-frame-based control method for UPQC under unbalanced and distorted load conditions. IEEE Transactions on Industrial Electronics. 2011; 58(9):3967–3975.
3. Zhu N, Xu D, Wu B, Liu F, Zargari NR, Kazerani M. Common-mode voltage reduction methods for current-source converters in medium-voltage drives. IEEE Transactions on Power Electronics. 2013; 28(2):995–1006.
4. Vinod khadkikar, Ambrish Chandra, “A novel structure for three phase four-wire distribution system utilizing unified power quality conditioner(UPQC),” IEEE Transaction on industry application, Vol.45,no.5,pp.1897-1902,Sep/oct.2009.
5. R. C. Dugan, M. F. McGranaghan, and H. W. Beaty, Electrical Power Systems Quality. New York: McGraw-Hill, 1996.
6. N. G. Hingorani and L. Gyugyi, Understanding FACTS: Concepts and Technology of Flexible AC Transmission Systems. New York: Institute of Electrical and Electronics Engineers, 2000.



INNO SPACE
SJIF Scientific Journal Impact Factor
Impact Factor: 8.118



ISSN INTERNATIONAL
STANDARD
SERIAL
NUMBER
INDIA



INTERNATIONAL JOURNAL OF INNOVATIVE RESEARCH

IN SCIENCE | ENGINEERING | TECHNOLOGY

 **9940 572 462**  **6381 907 438**  **ijirset@gmail.com**



www.ijirset.com

Scan to save the contact details